

Zero Clearance Firebox - WOOD

NOTE: Custom built to clients requirements and to current standards.

For Period Style Fireplaces Installation Instructions into Wood or Block Alcoves

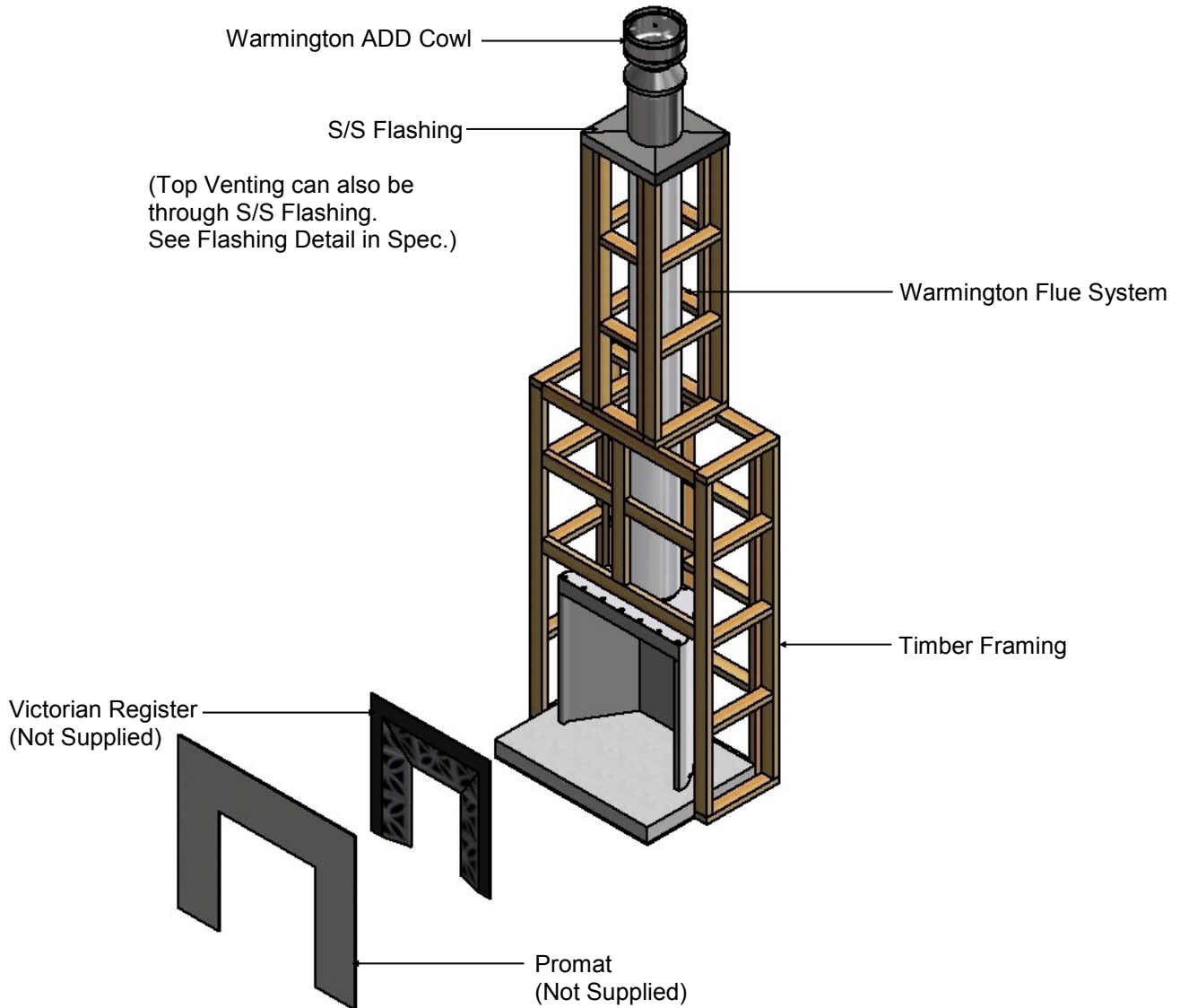

Related documents

Fire and flue system nstallation, and instructions to comply with ASNZS 2918:2001

Keep these instructions for further reference. Ensure that you have the correct and current installation details for the Warmington fireplace.

Installation

The Warmington unit is to be installed by a certified Warmington installer or an approved NZHHA installation technician.

See www.homeheat.co.nz/members for a certified NZHHA SFAIT Installer in your area.

A licenced certified gas fitter and licenced electrician are required to run power and gas supplies as required to the unit and any commissioning as part of the installation process. The heater must be installed according to these instructions and in compliance with all relevant building, gas fitting, electrical and other statutory regulations.

IMPORTANT

Read all the instructions carefully before commencing the Installation. Failure to follow these instructions may result in a fire hazard and void the warranty

POINTS TO CONSIDER PRIOR TO INSTALLATION

Location of the Fire. Open Fires are better located at one end of a room or area, as they project the heat away from their opening .

Venting to the Cavity.

This air is to allow the Cavity to Vent the Warm Air. This Warm Air helps keep the Fire and Flue System from getting to Cold . If the Flue and Fire get to Cold the System may soot often and require cleaning. Each Fire has different ways of venting the cavity .

The Topography of the Land .

The slope and position of the Land in relation to the Home has a bearing on how the wind will interact with the Fire and Flue System. Care needs to be taken to ensure that the Flue Termination is in the correct position to maximise performance .

The Prevailing Wind.

Care needs to be taken to ensure that the Flue Termination is in the correct position as wind and gusts that hits the Flue and Cowl System may overcome the Cowl and draft back down the Flue into the Home. This can be a combination of down draft and high pressure.

Hearth and Plinth:

The height of the Hearth off the Floor. The Finishing that is to be used on the hearth is to be allowed for at the design stage.

Positioning of the Flue System:

There is a maximum distance that an Offset Flue can be Installed. Reference to relevant standards.

Flue and Fire Clearance:

To be maintained to the Manufactures Instructions.

Pressure Differential, Venting & External Air into the Building :

All fires need air to burn and draw correctly, Kitchen Fans, Air Conditioning units, High Wind Zones, Naturally forming Draft spaces, can all have an effect on the pressure difference from inside the building to the outside. A lower pressure in the building may induce a draft down the flue system and back into the building causing the fire to smoke or spill into the building. **Care needs to be taken at the design and installation stage to adequately vent the building, or some mechanical system to ensure that there is always a neutral or positive pressure at the fireplace and a negative pressure at the flue outlet.** This will ensure that the draft in the flue system is always to the outside.

“CAITEC AIR” the limits and requirements. See details in these Spec's, on www.warmington.co.nz or contact your local Agent.

Wind Noise:

You may encounter wind noise in some installations. It is recommended to use an enclosed chase with a chimney pot to help reduce noise. There will always be some noise from the flue systems of all fireplaces.

INSTALLATION ORDER OF OPERATIONS

Prior to Construction and Installation

Important Notes: Custom built to clients requirements to current and relevant standards.

1. **Consult a licenced certified gas fitter for correct gas installation (If required).**
2. Install to current standards.
3. Install to manufacture's specifications.
4. All New Installations require a permit.
5. Allow for gas supply to heat cell at R.H. rear, and power supply to L.H. rear if required (check product).
6. For special requirements concerning materials (Timber Mantle and Surrounds) within close proximity of Warmington products, please contact your local Warmington Technical Consultant .
- 7.

Stage 1: Frame Construction Procedure by Builder.

1. Mark out Flue Centre.
2. Mark out Heat Cell Clearance requirements.
3. Build Timber Framing to Heat Cell Clearances and Chimney Chase Clearance requirements.
4. Ensure that the front face of Heat Cell Clearance alcove is left open and unframed to enable Installation of the Firebox. The Chimney Chase is left unlined for Installation of the Flue.
5. Construct Plinth only, to required height. *

Stage 2: Install Procedure by Certified “Warmington Installer” only.

1. Fit Fire to Plinth.(Ensure Gas Supply Line is fed through R.H. Side of Firebox if required.)
2. Fit Flue System.
3. Fit Cowl and Flashing System.
4. Fit Vents to Heat Cell Alcove and Chimney Chase, to cool the Heat Cell and ensure efficiency of CAITEC Technology.
5. Clean and touch paint up on the fires and cover if necessary.

Stage 3: Finishing Procedure by Builder.

1. Construct Hearth to required thickness. *
2. Finish Framing of Heat Cell Alcove.
3. Close in Heat Cell Alcove and Chimney Chase.
4. Finish Heat Cell Alcove and Hearth to customer's requirements (e.g. paint / tiles).
5. *** Note: Certified Installer can Install Hearth and Plinth.**

Maintenance.

Visually Inspect Fireplace and Flue System.
Ensure that Firebox is operated according to the Manufacture's Instructions.

ZERO CLEARANCE FIREBOX DIMENSION

Minimum Flue Height	
Flue Height	3600
Measured From Top of Firebox	B + 3600

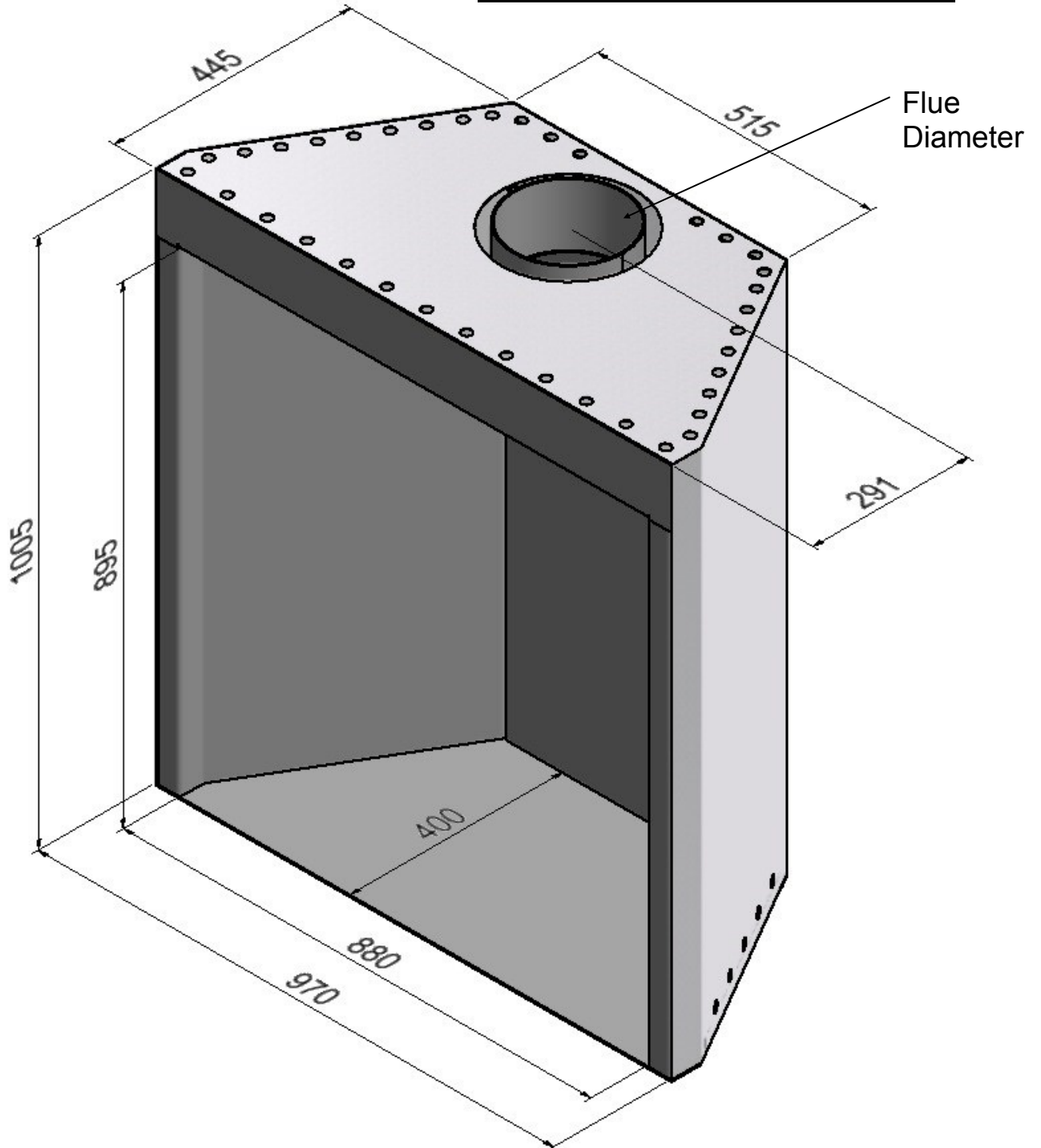

Note:
DO NOT FRAME OUT TO THESE DIMENSIONS CHECK HEAT CELL ALCOVE

FLUE DIMENSIONS		Option A	Option B
Cowl	1	200	250
Flue Diameter	3	200	250
Liner Diameter	3	250	300
Spacer	3	200/250	250/300
Bottom Spacer	1	200/250	250/300

CONCRETE FLOOR

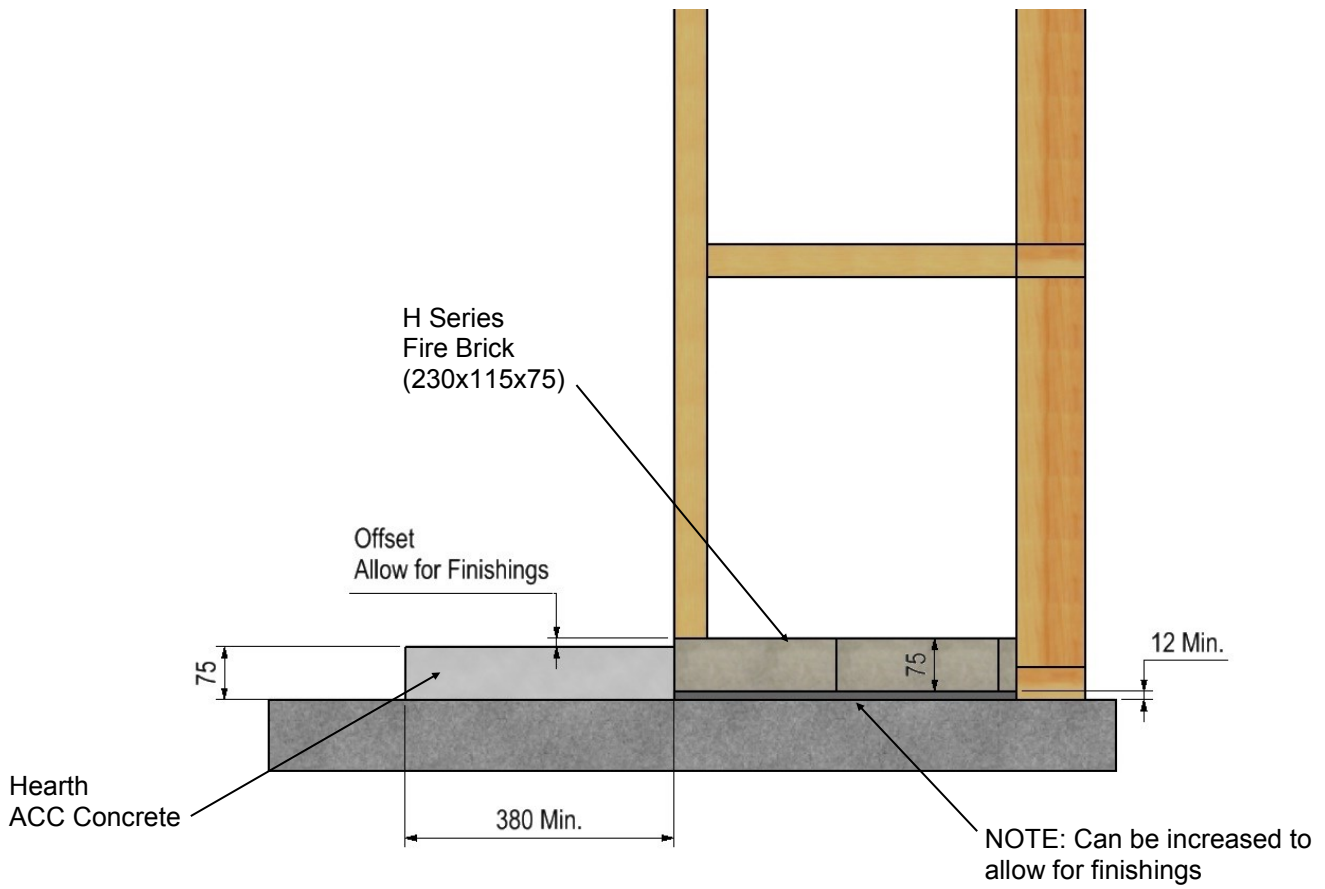

TIMBER FLOOR

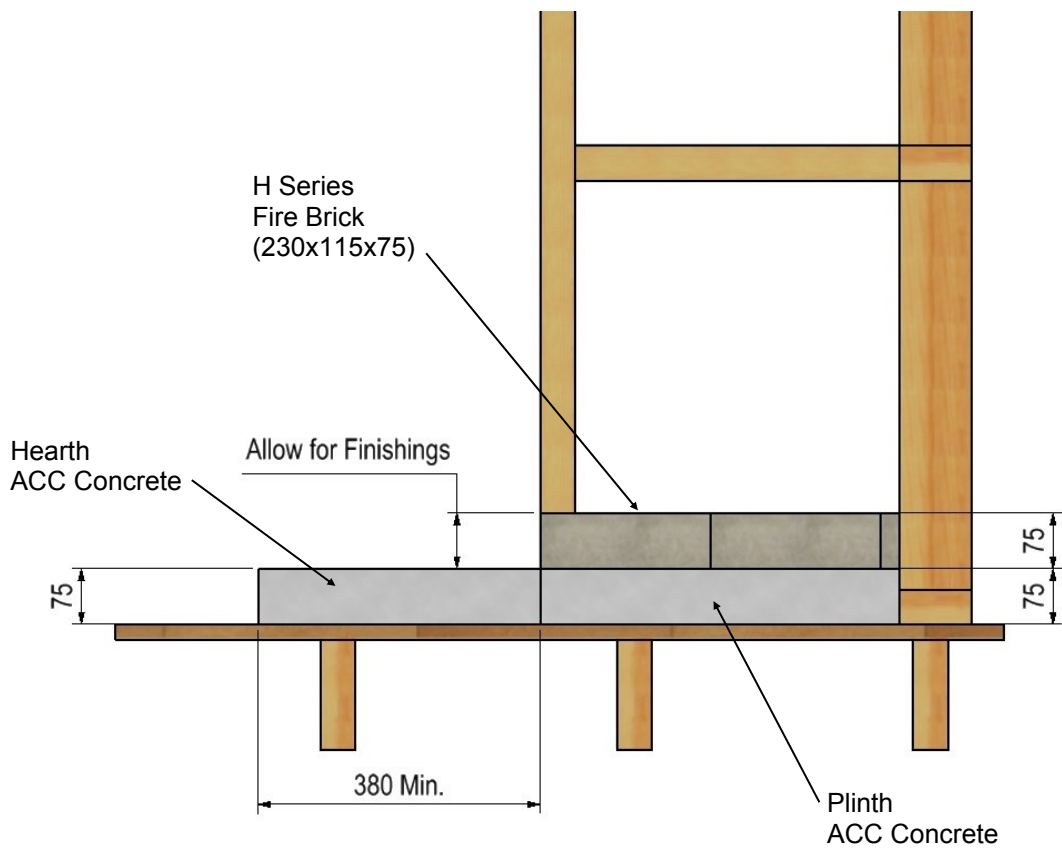

TIMBER FRAMING

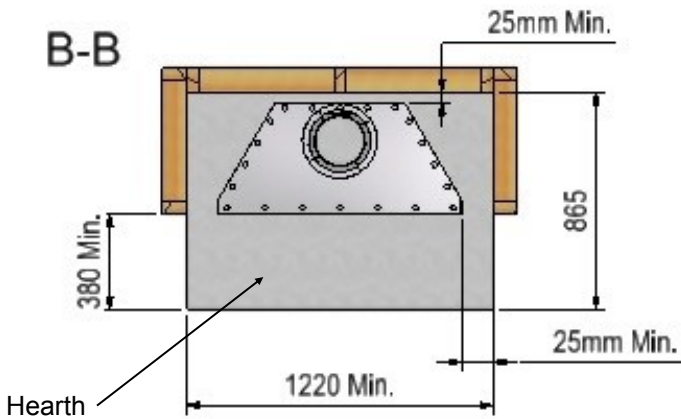

Note:
All Framing Dimensions are Internal Only

Note:
Centre Line of Flue is 'NOT' in Centre of Alcove

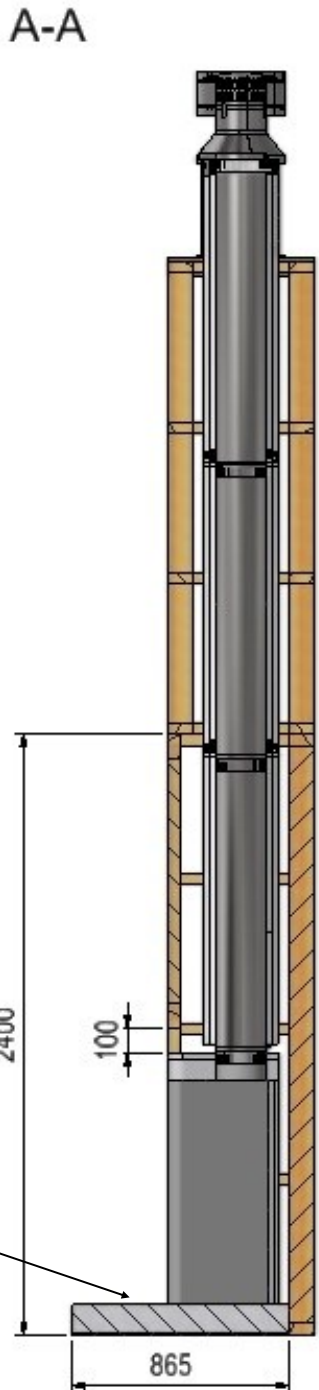
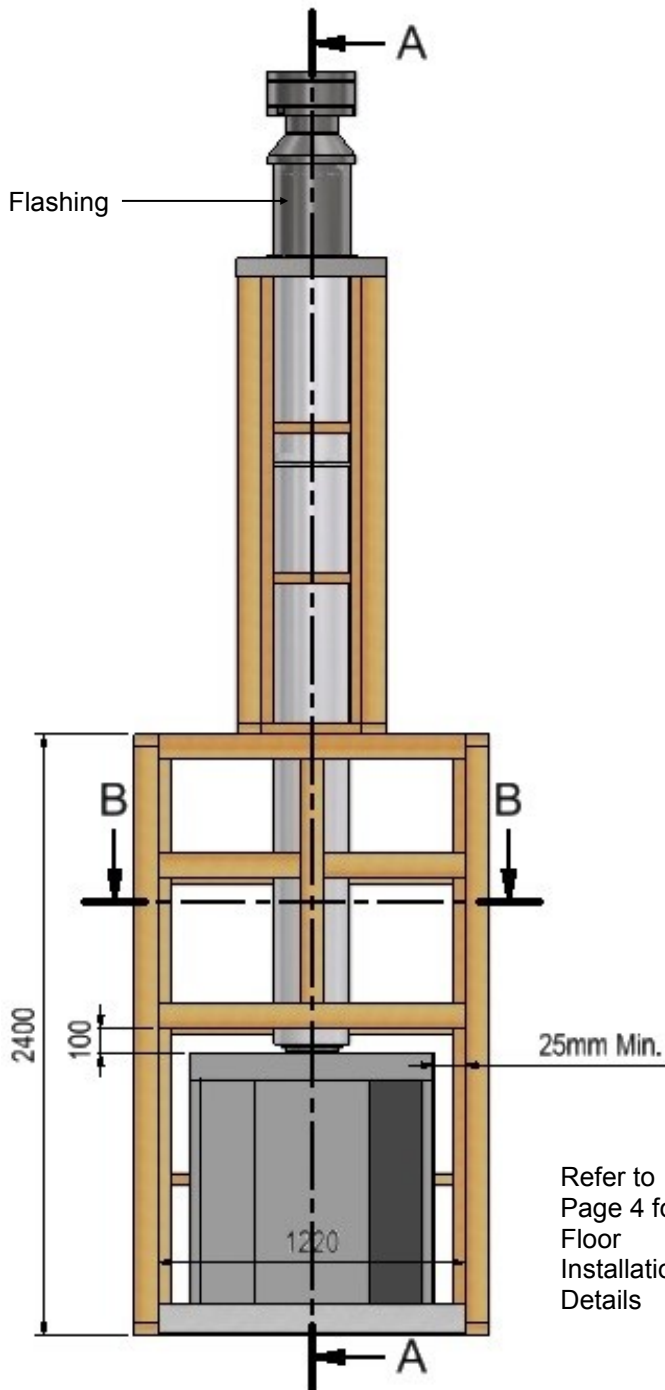

Refer to
Page 4 for
Floor
Installation
Details

GENERAL FITMENT OF VICTORIAN REGISTER

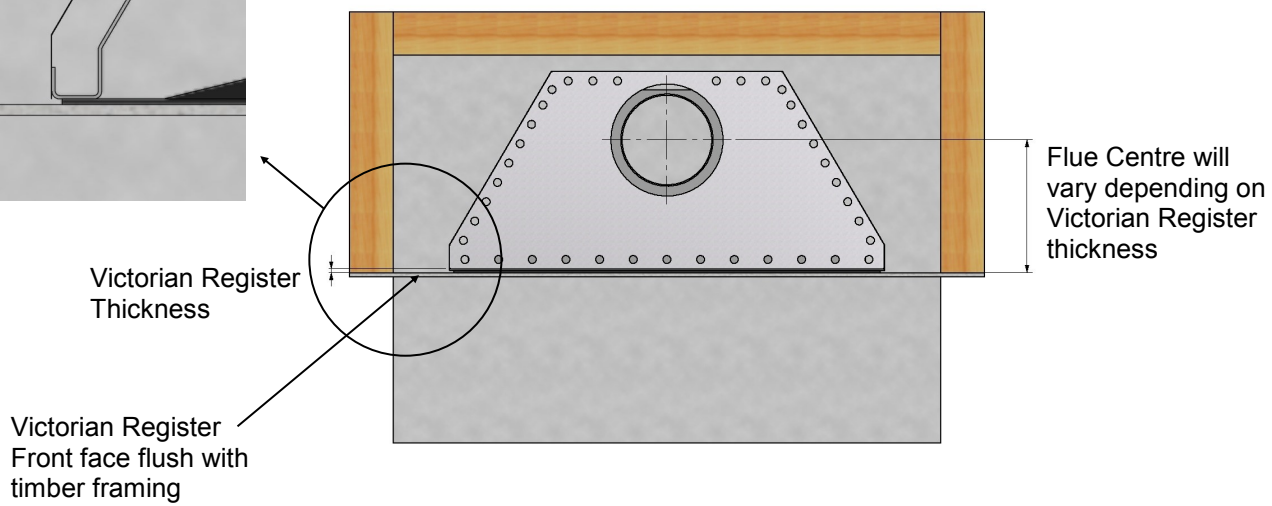
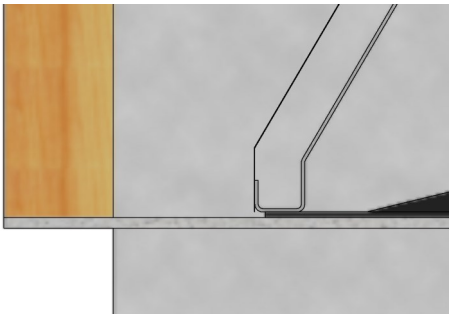
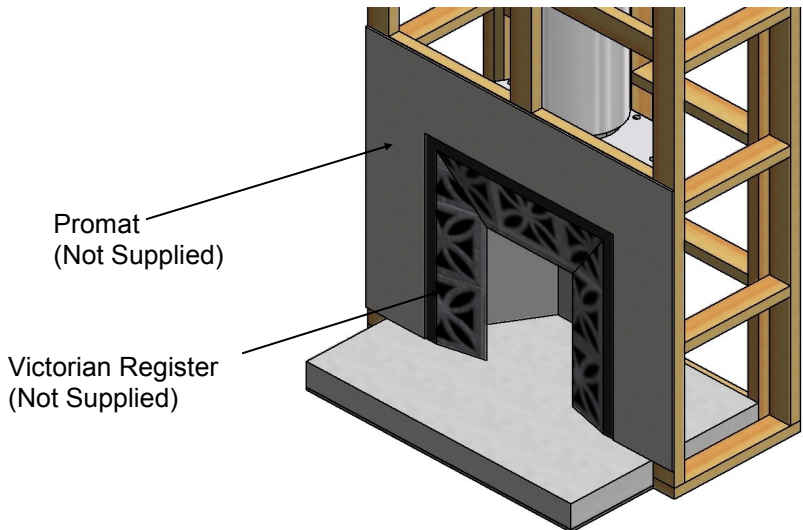
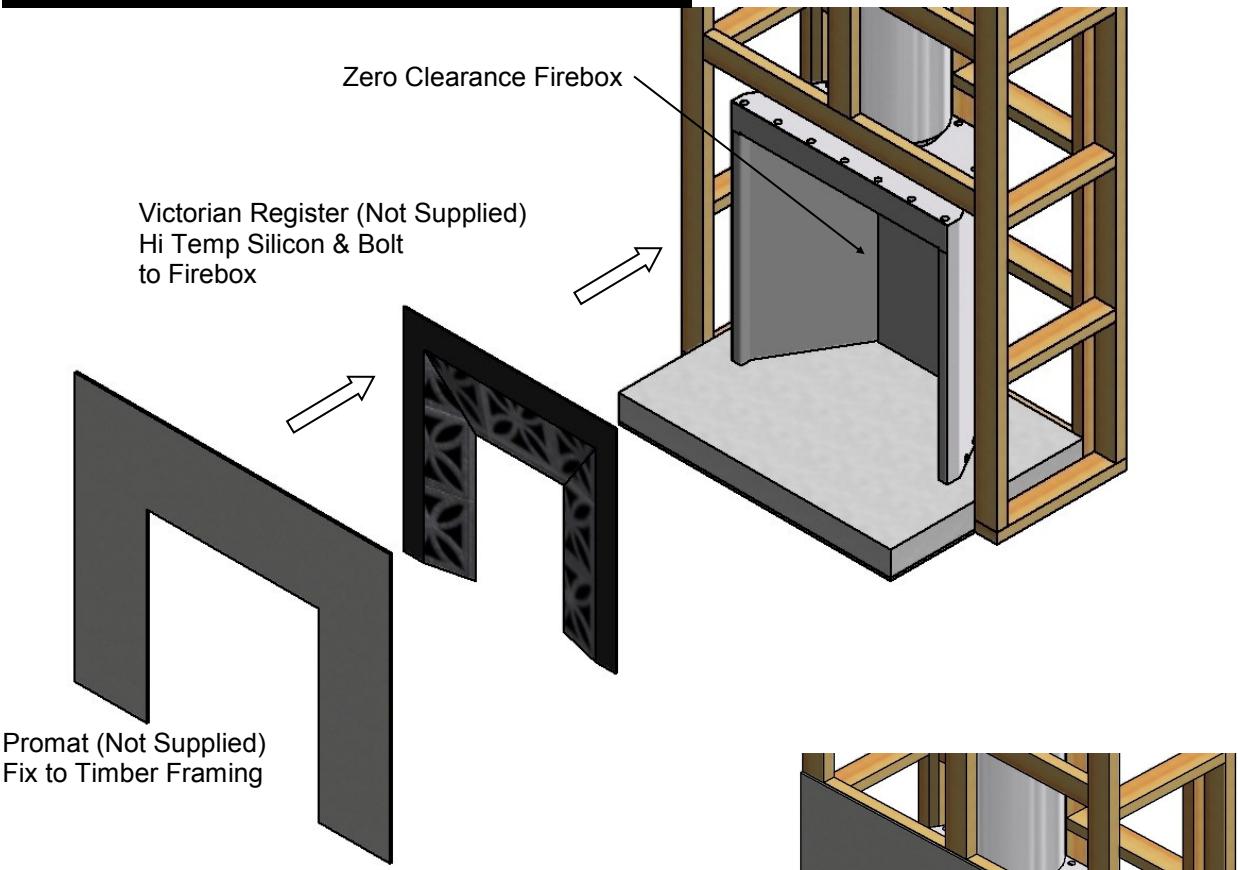

FLUE DETAILS DIMENSIONS

Minimum Flue Height	
Flue Height	3600
Measured From Top of Adaptor	B + F + 3600

FLUE DIMENSIONS		Zero Register 200 ø	Zero Register 250 ø
ADD Cowl	1	200	250
Flue Diameter	3	200	250
Liner Diameter	3	300	350
Spacer	3	200/300	250/350
Bottom Spacer	1	200/300	250/350

NOTE:
Ensure that a Standard Tested Warmington Flue system is used on the Warmington fires.

FLUE SYSTEM INSTALLATION GUIDE

This is a general installation guide only – Contact a “NZHHA Installer” for Installation Advice.
See : www.homeheat.co.nz , choose “members” & pick your Area & Fire type (wood / Gas etc)
this will provide you with a NZHHA Certified Installer (use the SFAIT Installers Only .)

1. Install the first length of flue pipe with the crimped end down, inside the Adaptor collar, ensure that the flue pipe is sealed into the collar with exhaust sealant. Rivet the flue in 3 places around the Adaptor collar. Place a spacer around the flue pipe approximately 150mm above the adaptor collar. Secure in position by tightening the screw and nut.
2. Install the second length of flue pipe with the crimped end down and fit by riveting in at least 3 places around the flue pipe joint. Ensure that the flue is sealed into position with sealant.
3. Install the first section of flue pipe liner with the Crimped end up, over the flue pipe and over the spacer that is fixed to the flue pipe. This spacer will keep the liner concentric about the flue pipe.
4. Position flue spacer at the flue pipe joint for every length of “Flue pipe” and “Liner”. Repeat the Steps from 1 – 4 to the installed required height of the flue system. The flue system is to comply with AS/NZS 2918:2001 4.9.1

- a “the flue pipe shall extend not less than 4.6m above the top of the floor protector.”
- b “ the minimum height of the flue system within 3 m distance from the highest point of the roof shall be 600mm above that point.”
- c “the minimum height of the flue system further than 3 m from the highest point of the roof shall be 1000mm above the roof penetration.”
- d “no part of any building lies in or above a circular area described by a horizontal radius of 3 m about the flue system exit.”

1. **NOTE:** The last length of flue pipe needs to extend past the liner so that when the “top spider” and the “Flashing cone” are fitted, that the “flashing cone” and the “flue pipe” are **flush**, or that the “flue pipe” is **5mm lower** than the “Flashing cone”.
2. Fit the “Top Spider” into position, ensure that the legs of the spider are fitted inside the liner and that the spider is positioned hard down onto the liner and tighten with the screw and nut.
3. Place the “Flashing cone” over the “flue pipe” and press hard down onto the “Top Spider”. (Note that the “Flue pipe” and the “Flashing Cone” are either flush or the “Flue pipe” is 5mm Lower than the “Flashing cone”.) Ensure that the “Flashing cone” is clear for the venting from the “Liner” and the “flue pipe”.
4. Fit the “Cowl” to the top of the flue pipe. The “Cowl”, “Flashing cone”, and the “Flue pipe” can be secured to each other with the uses of a stainless steel self tapping screw. This will allow the “Cowl” to be removed for cleaning.
5. Flue system may require Bird Proofing due to the installation and locations, discuss this with your installer for the best advice.
6. If the Flue system is installed into a “Chimney Chase”, allow for air vent as close to the top of the chase as practical, or allow venting through the “Chimney Chase Flashing”. A “Venting Flashing cone” and a 25mm gap around the Liner with a “Venting Flashing Cone-Spider” can be used.

Note: FLUE SYSTEMS CASING
Flue system may require to be Doubled lined to comply.
Ref AS/NZS:2918:2001 4.3 Flue pipe casing.

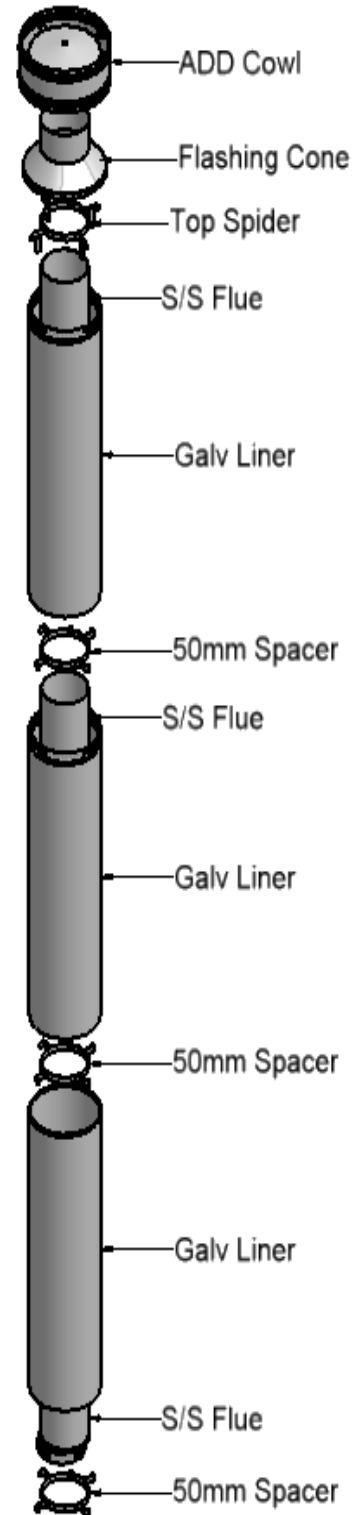

**FLUE PENETRATION Vented through Alcove
(Single lined Flue System)**

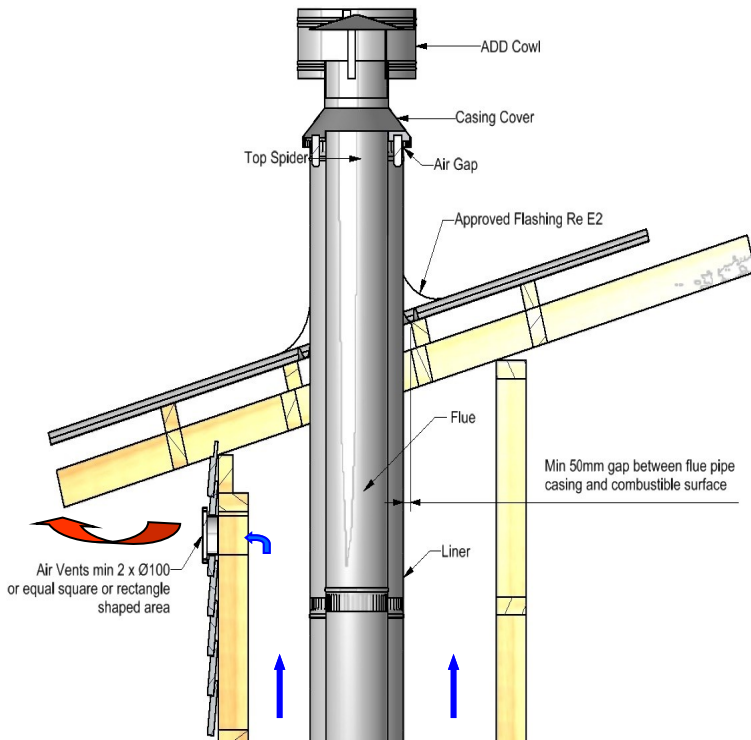

**FLUE PENETRATION Vented through Alcove
(Double lined Flue System)**

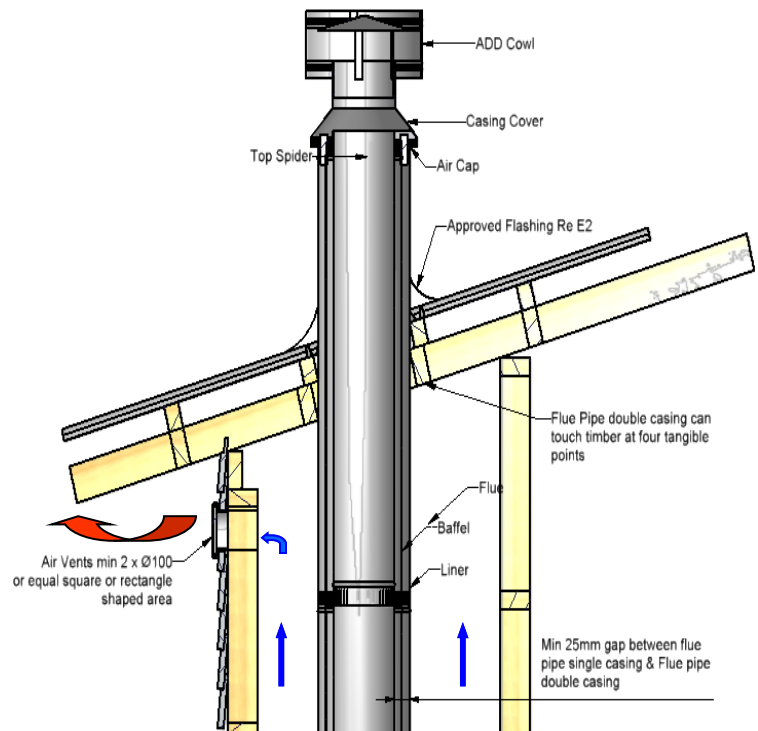

FLUE PENETRATION Vented through Top Flashing

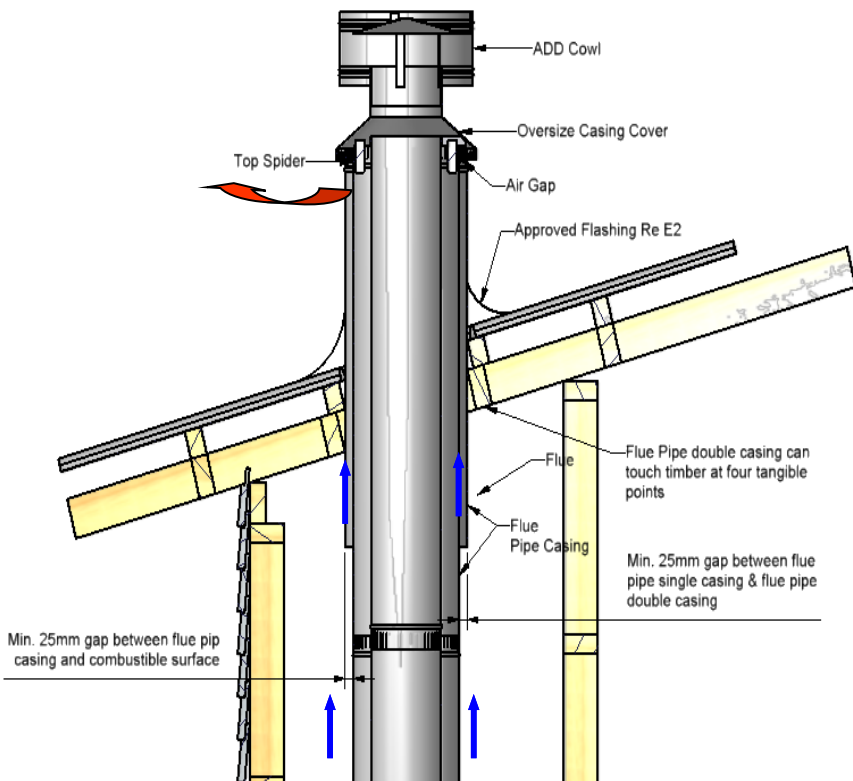

Note: FLUE SYSTEMS CASING
Flue system may require to be Doubled lined to comply.
Ref AS/NZS:2918:2001 4.3 Flue pipe casing.

Note:
External Requirements
Refer to AS/NZS2918:2001 4.9.1
Install Flue system to AS/NZS2918:2001
When using a rubber or Bitumen flashing (Butynol, Dectite) an Additional Flue pipe Baffle is required.
All external air vents & ceiling penetrations must be bird proofed with permanently fixed screens.
All flashing to comply with E2.
All external air vents and ceiling penetrations are to be Vermin and Rodent proof.

Test Report Number	Date of Report
04/1039	20 th July 2004
04/1040	20 th July 2004
04/1041	20 th July 2004

CHIMNEY CHASE FLASHING DETAILS

SETTING ADD COWL AND FLASHING CONE HEIGHT

General Chimney Chase Flashing Lay Out

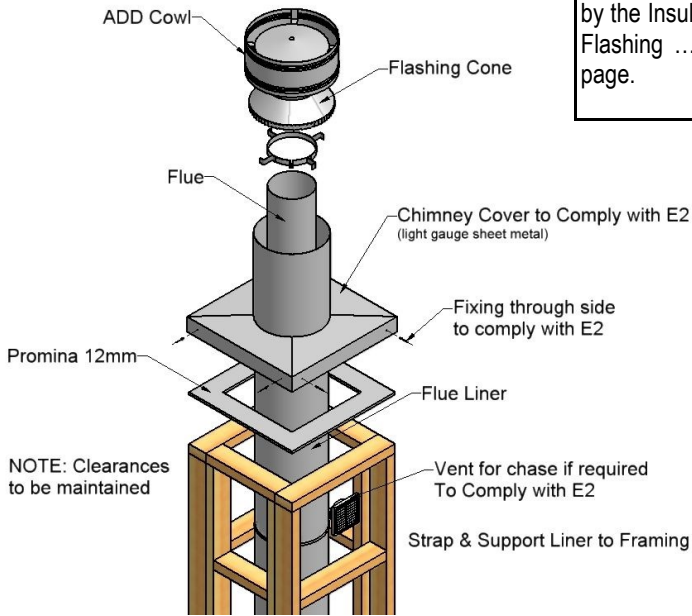

Note:
Flashing Spigot height is determined by the Insulation that is fitted under the Flashing ... See Details at bottom of page.

STEP 1

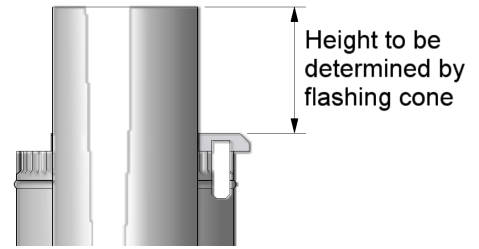

STEP 2

Flue 5mm Below Top Of Flashing Cone

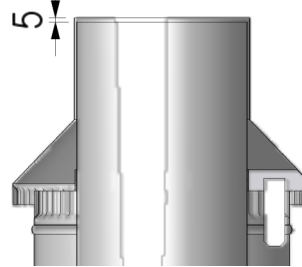

STEP 3

ADD Cowl Sits on Top of Flashing Cone, screw to secure

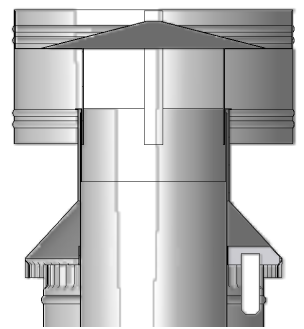

'CHIMNEY CHASE FLASHING' and 'AIR VENTILATION' OPTIONS:

VENTING THROUGH CHIMNEY CHASE

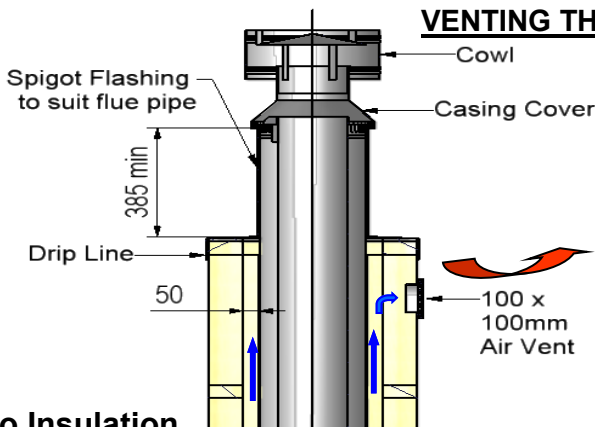

"No Insulation under flashing"

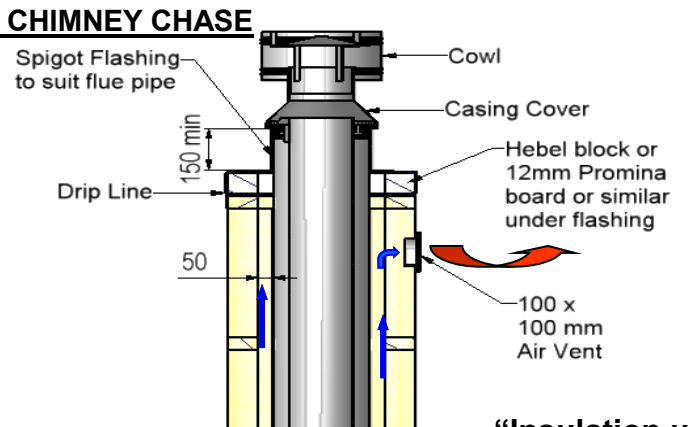

"Insulation under flashing"

VENTING THROUGH FLASHING

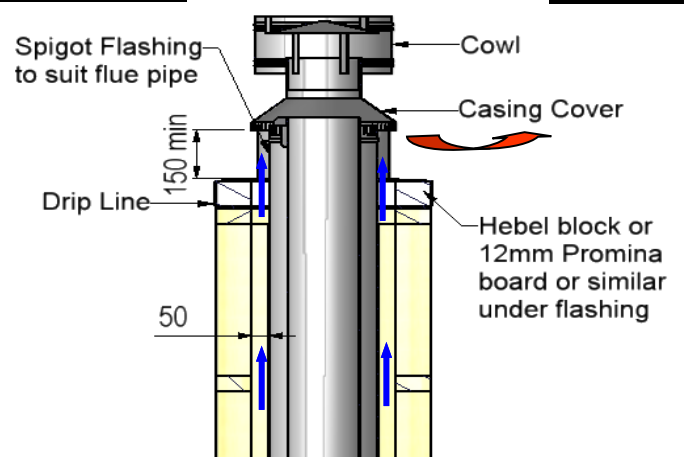
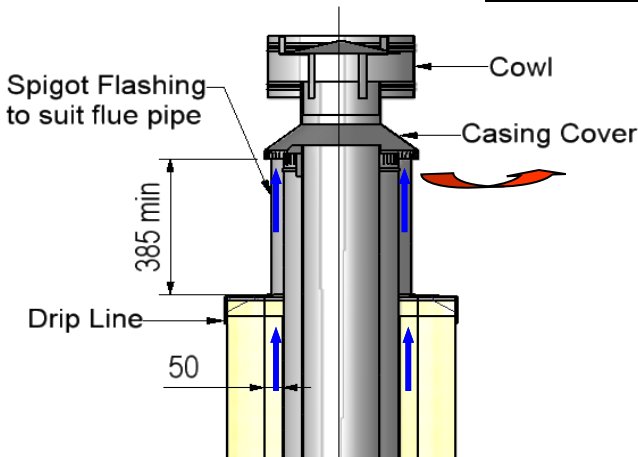

FLUE HEIGHT MINIMUM DETAILS

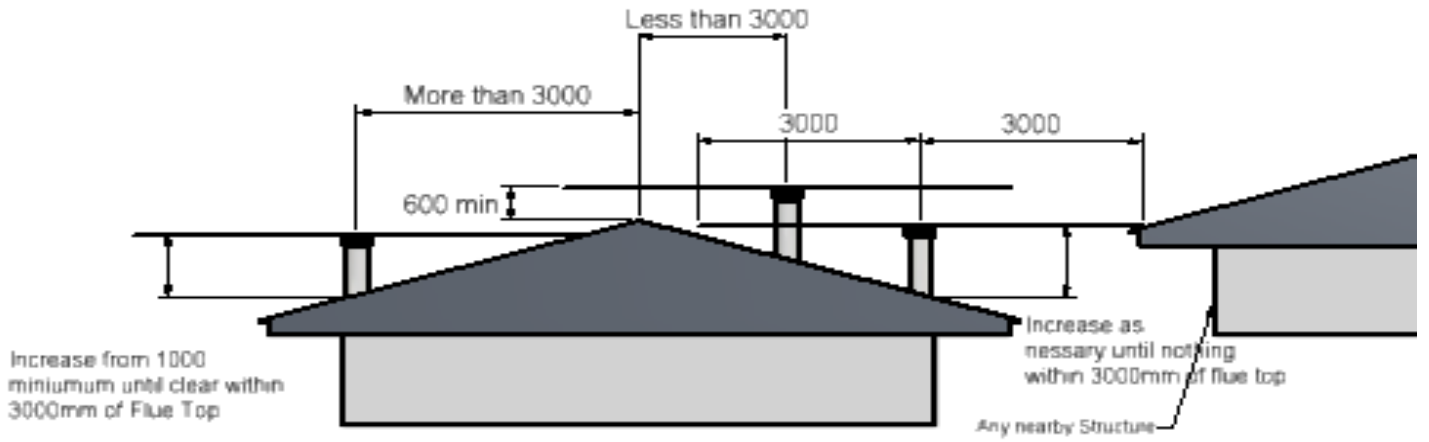

The Flue exit is to comply to relevant standards.

3D View

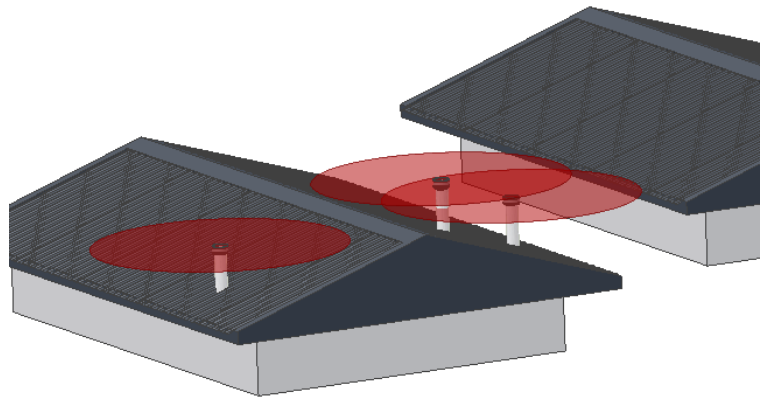

FRAME OUT AND TRIM OUT DETAILS FOR CHIMNEY CHASE

Option X – Singled Lined Flue System

Option Y – Double Lined Flue System

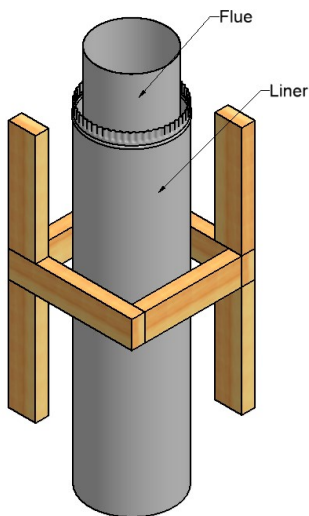

X = Liner Diameter + 50 mm

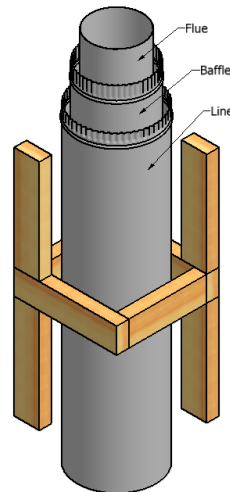
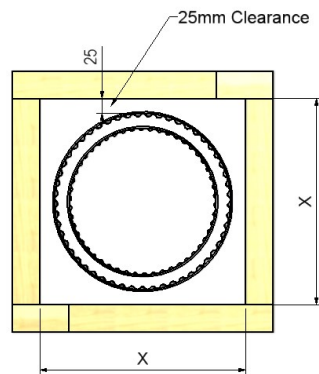

Y = Liner Diameter

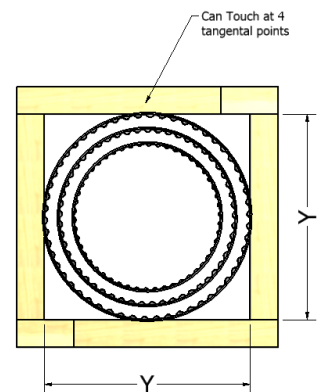

COMBUSTIBLE MANTLE CLEARANCES

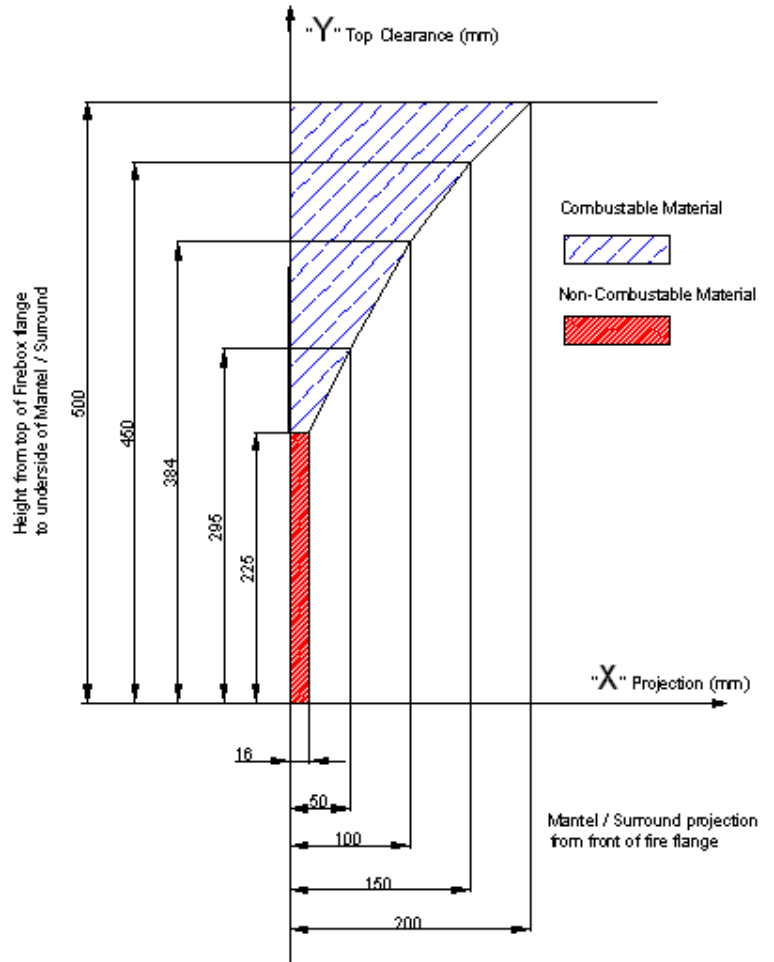
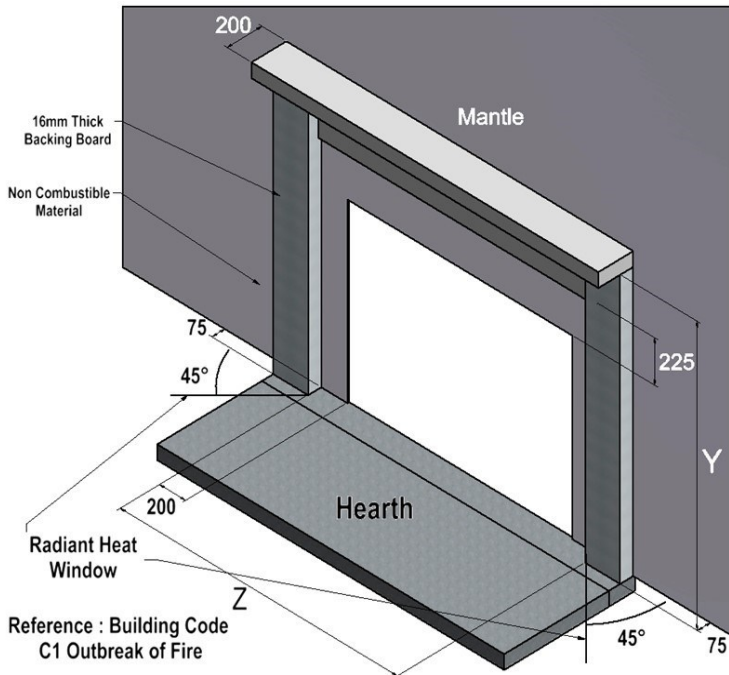

RAISED HEARTH CLEARANCES

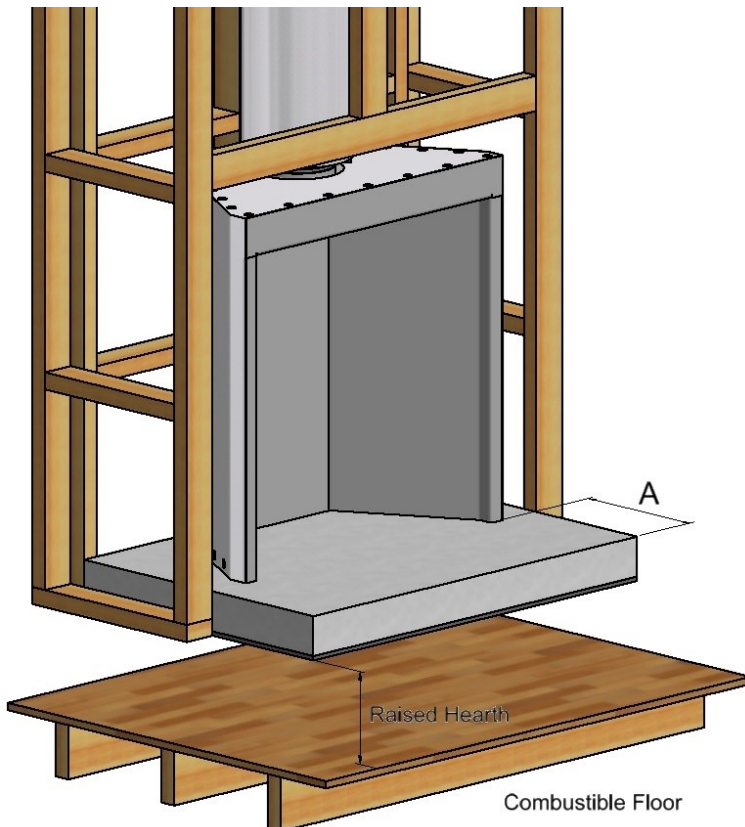

Note: For Combustible Floors
Minimum Hearth of 380mm (A) must be maintained at any given height.

GENERAL NOTES

NOTES:

- Custom built to clients requirements to current and relevant standards.
- These installation and operating instructions should be kept in a safe place. Should you require another copy, download from the **Warmington** website www.warmington.co.nz
- Warranty - for full details on product warranties, contact your local Authorised Warmington Retailer.
- This appliance must be installed in accordance with the manufacturer's written instructions to comply with the **Warmington** warranty.
- The appliance and flue system must be installed in accordance with relevant standards and the appropriate building codes.
- This appliance must be serviced annually and any service operation must be carried out by a qualified service person.

WARNINGS:

- **WARNING; ANY MODIFICATION OF THE APPLIANCE THAT HAS NOT BEEN APPROVED IN WRITING BY THE TESTING AUTHORITY IS CONSIDERED A BREACH OF NZ STANDARDS.**
- **WARNING; DO NOT USE OR STORE FLAMMABLE LIQUIDS OR AEROSOLS IN THE VICINITY OF THIS APPLIANCE WHILST IN OPERATION.**
- **WARNING; DO NOT PLACE FLAMMABLE MATERIALS ON OR AGAINST THIS APPLIANCE.**
- **CAUTION:** THIS APPLIANCE SHOULD BE MAINTAINED AND OPERATED AT ALL TIMES IN ACCORDANCE WITH THESE INSTRUCTIONS.
- **CAUTION:** ALL SERVICING MUST BE CARRIED OUT BY AN AUTHORISED SERVICE TECHNICIAN.
- **CAUTION:** MAKE SURE THE USE OF CORRECT FUEL TYPE WITH THIS APPLIANCE.

NOTE: Keep a copy of these instructions for operating and maintenance guidelines.



Industries 1994 LTD
PO Box 58652, Botany 2163, Auckland www.warmington.co.nz