

L/H & R/H SI 780T Corner Fire

Custom Open Corner Fire - Wood Burner Installation Instructions

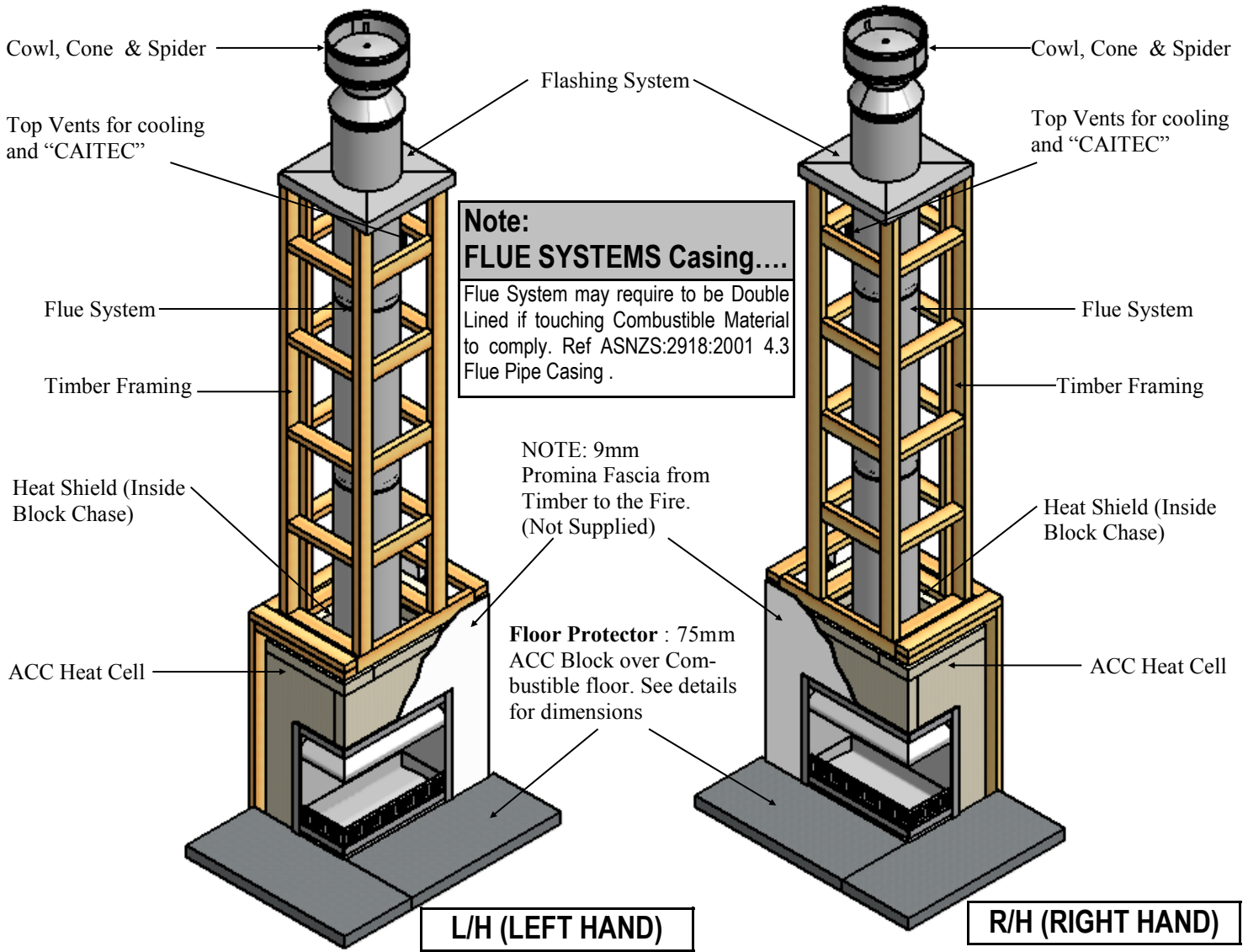

Visit www.warmington.co.nz for Spec's, DWG's and PDF uploads of fires

Fire , Flue System and Instructions to Comply with ASNZS 2918:2001

Keep these Instructions for further reference.....Ensure that you have the correct and current Installation details for the Warmington Fire

Installation

The Warmington unit is to be Installed by a Certified Warmington Installer or an Approved NZHHA Installation Technician .
See www.homeheat.co.nz/members for a Certified NZHHA SFAIT Installer in your area .

IMPORTANT

Read all the Instructions carefully before commencing the Installation. Failure to follow these Instructions may result in a Fire Hazard and void the warranty

POINTS TO CONSIDER PRIOR TO INSTALLATION

Location of the Fire. Open fires are better located at one end of a room or area, as they project the heat away from their opening.

The Topography of the land .

The slope and position of the land in relation to the home has a bearing on how the wind will interact with the fire and flue system. Care needs to be taken to ensure that the flue termination is in the correct position to maximise performance.

The Prevailing Wind.

Care needs to be taken to ensure that the flue termination is in the correct position as wind and gusts that hits the flue and cowl system may overcome the cowl and draft back down the flue into the home. This can be a combination of down draft and high pressure.

Hearth and Plinth:

The Height of the Hearth off the Floor. The Finishing that is to be used on the Hearth is to be allowed for at the design stage.
Note : Ensure Air Intake at Base of Firebox is not blocked or restricted .

Positioning of the Flue System:

There is a maximum distance that an offset flue can be Installed . Reference to AS/NZS 2918:2001 .

Flue And Fire Clearance:

To be maintained to the Manufactures Instructions &/or Comply with appropriate Standards & Building Codes .

Pressure Differential, Venting & External Air into the Building :

All fires need air to burn and draw correctly, Kitchen Fans, Air Conditioning units, High Wind Zones, Naturally forming Draft spaces, can all have an effect on the pressure difference from inside the building to the outside. A lower pressure in the building may induce a draft down the flue system and back into the building causing the fire to smoke or spill into the building. **Care needs to be taken at the design and installation stage to adequately vent the building, or some mechanical system to ensure that there is always a neutral or positive pressure at the fireplace and a negative pressure at the flue outlet.** This will ensure that the draft in the flue system is always to the outside.

“CAITEC AIR” the limits and requirements. See details in these Spec’s

Wind Noise:

You may encounter wind noise in some installations. It is recommended to use an enclosed chase with a chimney pot to help reduce noise. There will always be some noise from the flue systems of all fireplaces.

INSTALLATION ORDER OF OPERATIONS

Prior to Construction and Installation Important Notes:

Install to AS/NZS 2918:2001.

Install to Manufacture’s Specifications.

All New Installations require a permit.

For special requirements concerning materials (timber mantle and surrounds) within close proximity of Warmington products, please contact your local Warmington Technical Consultant.

Stage 1: **Frame Construction Procedure by Builder.**

Mark out flue centre.

Mark out heat cell clearance requirements.

Construct plinth only, to required height. *

Stage 2: **Install Procedure by Certified “Warmington Installer” only or see www.homeheat.co.nz go to “members” & follow Instructions to get a Certified NZHHA SFAIT Installer .**

Install Fire to Plinth.

Install Adaptor to Firebox.

Construct Heat Shield & ACC Block Enclosure around Fire and Adaptor.

Install Flue System.

Install Cowling System and Flashing System .

Stage 3: **Finishing Procedure by Builder.**

Construct Hearth to required Thickness. *

* Note: Certified NZHHA SFAIT Installer can also Install Hearth and Plinth.

Ensure that the Warmington and Flue System is Swept Annually or more frequently if required.

To Sweep Flue and Firebox:

Cover Front of Fire with sheets.

Remove Cowl from Top of Chimney.

Sweep from the top, down the Flue.

Remove all soot and ash.

Ensure Cowl and Bird Protection is clean and replaced.

Visually Inspect Fireplace and Flue System.

WARMINGTON FIREBOX DIMENSION

Firebox		L/H SI 780TC	R/H SI 780TC
Firebox Width	A	780	780
Firebox Height	B	680	680
Firebox Depth	C	405	405
Front Flange Width	D	805	805
Flange Height	E	705	705
Side Flange Width	F	380	380
Adaptor Height	G	265	265
To Centre of Flue	K	275	275
Flue	L	250	250
Flue Liner	M	350	350
Flange to Heat Shield	Z	85	85
Heat Output	kW		
Peak*		22	22
Range		15 - 17	15 - 17

*Estimated unless stated otherwise.

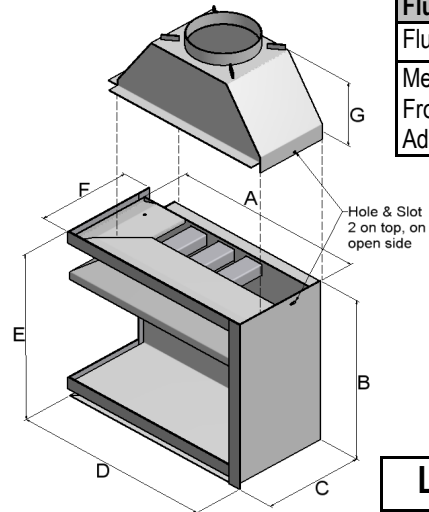

Minimum Flue Height	
Flue Height	3600
Measured From Top of Adaptor	B + G + 3600

L/H (LEFT HAND)

Note:
DO NOT FRAME OUT TO THESE DIMENSIONS CHECK HEAT CELL ALCOVE ON PAGE 5 & 6.

FIREBOX HEAT SHIELD CABINET

Firebox		L/H SI 780TC	R/H SI 780TC
Cabinet Width	H	730	730
Cabinet Height	I	1020	1020
Cabinet Depth	J	385	385

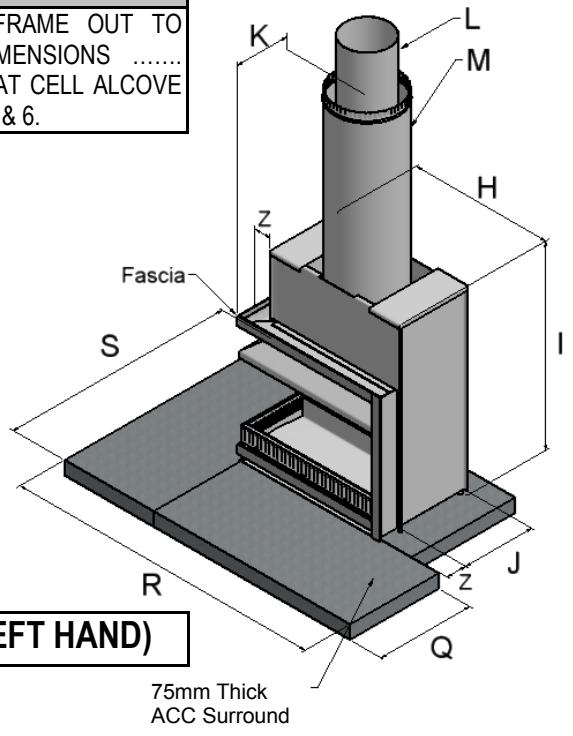

L/H (LEFT HAND)

FIREBOX ACC HEAT CELL

Firebox		L/H SI 780TC	R/H SI 780TC
Surround Width	HH	950	950
Surround Height	II	1120	1120
Surround Depth	JJ	585	585

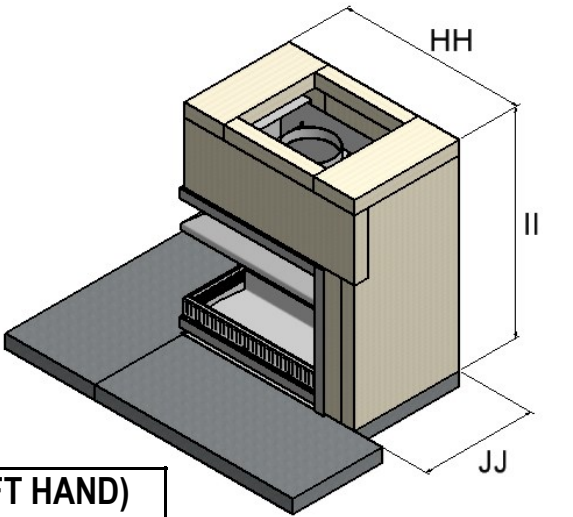

L/H (LEFT HAND)

Adaptor Fitting	
Seal adaptor to Firebox using High-temp Gasket Sealant . Bolt through holes provided .	
Seismic restraint	
Secure Firebox down through Seismic Restraints provided.	
Check List	
Firebox	
Adaptor (Fastenings)	
Ash pan	
Louvers	
Badge	
Packed By	

FIREBOX INSTALLATION

This is a general installation guide only – Contact a “NZHHA Installer” for Installation Advice.
 See : www.homeheat.co.nz , choose “members” & pick your Area & Fire type (wood / Gas etc) this will provide you with a NZHHA Certified Installer (use the SFAIT Installers Only .)

1. All the dimensions are Minimums
2. Fit the Plinth into position in the Cavity. If on a Wooden Floor ensure that an Insulating Plinth is fitted as per the Specifications. **Ensure that the Plinth is elevated to allow for Finishing on the Hearth. (See Hearth and Plinth details Below)**
3. Assemble Back Panel and Side of the Heat Shield, position into Cavity.
4. Fit the Firebox into the Cavity, allow for the Promina Board to fit behind the Flange of the Firebox and to the Timber Framing. (Approx 10mm) Bolt the Firebox to the Plinth & through to the Floor with the Bolting Points provided on the Left and Right Hand Sides of the Firebox (Seismic Restraints).
5. Fit the Adaptor to the Firebox. Ensure that High Temp Sealant is used between the Fire and Adaptor. Bolt into position with the bolts provided on the Left and Right Hand Sides of the Firebox.
6. Install the Flue System .
7. Fit the Top Front & Side Lintels & of the Heat Shield and rivet into position . Fit the Top Caps to the Heat Shield .
8. Install Hebel Heat Cell around Firebox and Adaptor .
9. 9mm Promina/Supalux Non Combustible Board must be used when closing down Cavity . Not Supplied .

HEARTH & PLINTH CONSTRUCTION DETAILS

IMPORTANT NOTE :

Note: Hearth and Plinth Construction.

For Combustible Flooring an Insulating Hearth and Plinth of 75mm ACC Block is required.

Plinth to be Offset above Hearth by the Hearth Finishing's (e.g. Tiles / Granite / Plaster / etc)

Offset for
Hearth
finishing

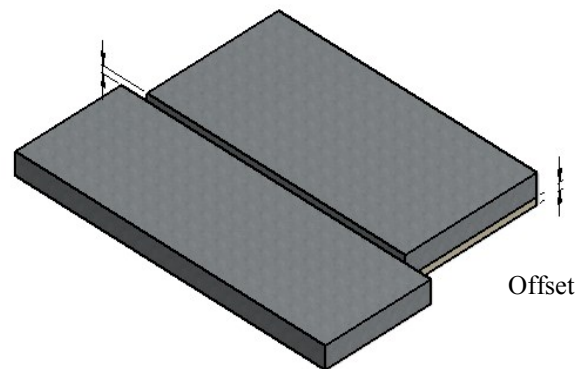

***Note: If Solid Plastering the Heat Cell structure, it is recommended to use a Fibreglass Mesh with a Latex Based Plaster to minimise the chance of the Plaster cracking. (See your Solid Plasterer for correct materials and applications).**

Visit the Warmington Web Site for “Hebel” instruction (PDF Download).. www.warmington.co.nz

SEISMIC RESTRAINT

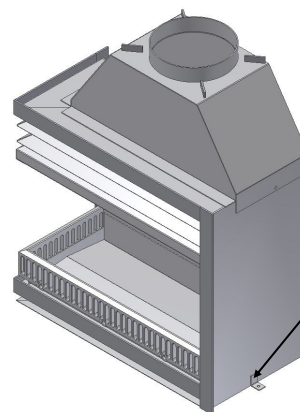

Seismic Restraint
Secure Firebox through
Anchor points provided

“CAITEC” TECHONOLGY—ROOM AIR REPLACEMENT

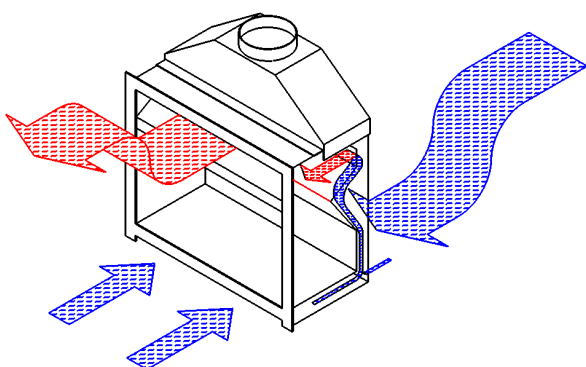

Caitec” draws air from an external air source to ensure that the open fire has pre-heated combustion air maximising efficiency while maintaining the home at constant pressure equilibrium, reducing the risk of back drafting .

Ensure that the cavity is vented to Outside fresh Air and the Warmington will take care of the rest. 2 x 100mm Diameter vent are required (Or equivalent to that.)

Builder to supply external air to the Cavity and the “Warmington Fire” takes care of the rest.

WARMINGTON FIREBOX DIMENSION

Firebox		L/H SI 780TC	R/H SI 780TC
Heat Cell Clearance Width	N	970	970
Heat Cell Clearance Depth	O	610	610
Heat Cell Clearance Height	P	1145	1145
Hearth Projection	Q	500	500
Hearth Front Width	R	1605	1605
Hearth Side Width	S	1175	1175
Front Window Width	V	970	970
Side Window Width	W	610	610
Window Height	X	1145	1145
Chimney Chase Clearance	Y	450	450

WARMINGTON FIREBOX DIMENSION

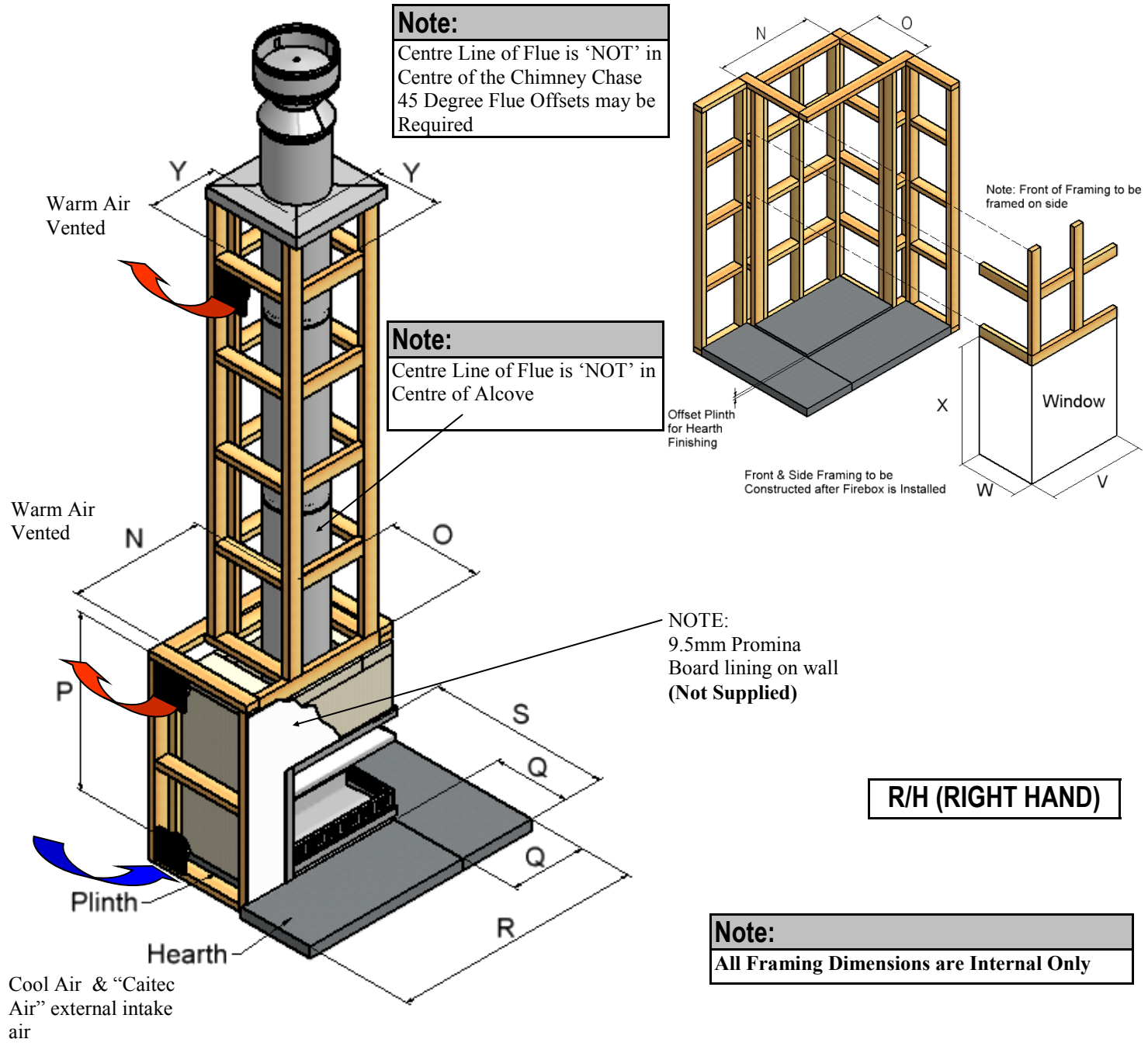

R/H (RIGHT HAND)

Note:
All Framing Dimensions are Internal Only

TIMBER : PLAN, FRONT ELEVATION & CROSS SECTION

Firebox		L/H SI 780TC	R/H SI 780TC
Hearth Front Width	R	1605	1605
Hearth Side Width	S	1175	1175
Plinth Width	T	950	950
Plinth Depth	U	585	585
Centre of Flue Front	J	445	445
Centre of Flue Side	K	275	275
Chimney Chase Clearance	X	450	450

Note:
Centre Line of Flue is 'NOT' in Centre of Alcove

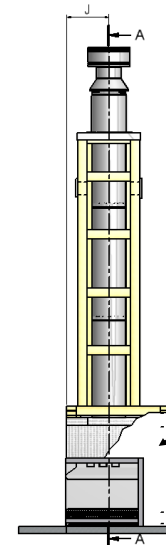
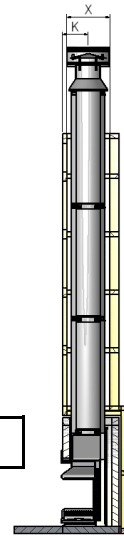
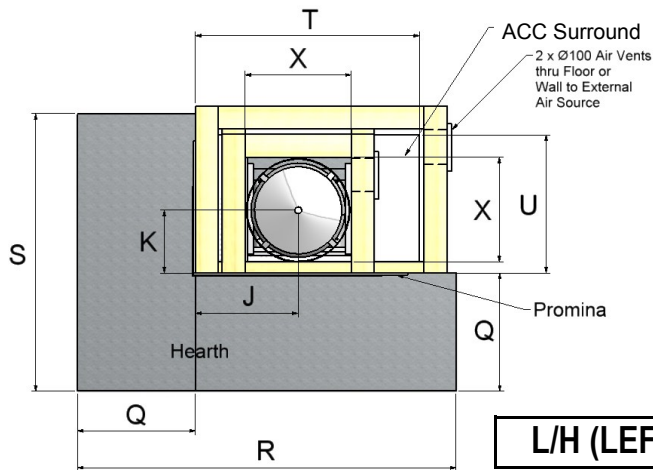

NOTE:
9.5mm Promina Board lining on wall (Not Supplied)

BLOCK : PLAN, FRONT ELEVATION & CROSS SECTION

Firebox		L/H SI 780TC	R/H SI 780TC
Hearth Front Width	RR	1690	1690
Hearth Side Width	SS	1190	1190
Plinth Width	TT	1000	1000
Plinth Depth	UU	500	500
Centre of Flue Front	JJ	445	445
Centre of Flue side	KK	275	275

Note:
Centre Line of Flue is 'NOT' in Centre of Alcove

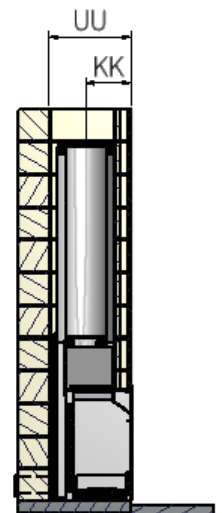
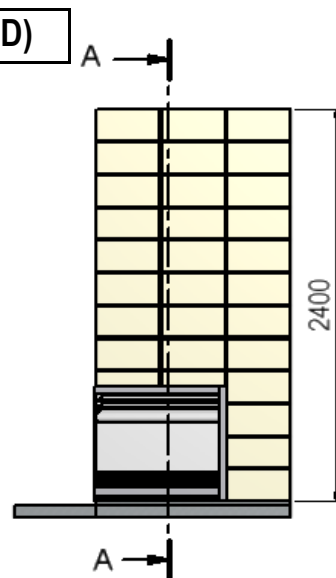
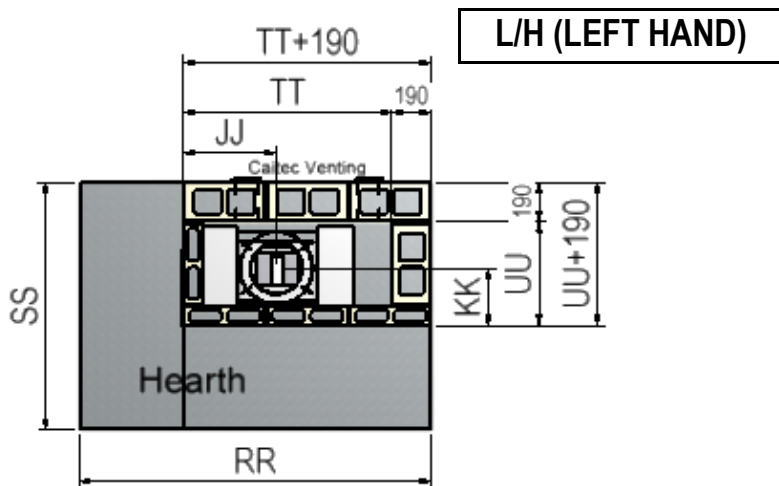

BLOCK ALCOVE & TRIM OUT DETAILS

Firebox		L/H SI 780TC	R/H SI 780TC
Heat cell Clearance Width	OO	1000	1000
Heat Cell Clearance Depth	PP	500	500
Heat Cell Clearance Height	QQ	2400	2400
Hearth Front Width	RR	1690	1690
Hearth Side Width	SS	1190	1190
Hearth Depth	ZZ	500	500
Window Height	VV	680	680
Window Front Width	WW	790	790
Window Side Width	XX	360	360
Chimney Chase Clearances	YY	450	450

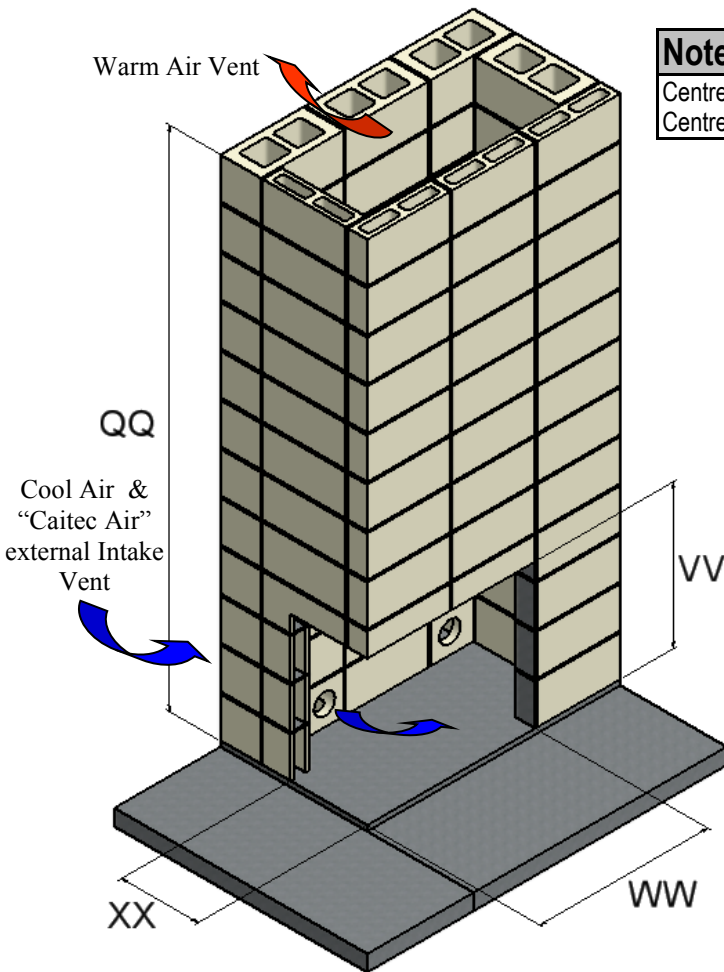

Note:
Centre Line of Flue is 'NOT' in Centre of the Chimney Chase

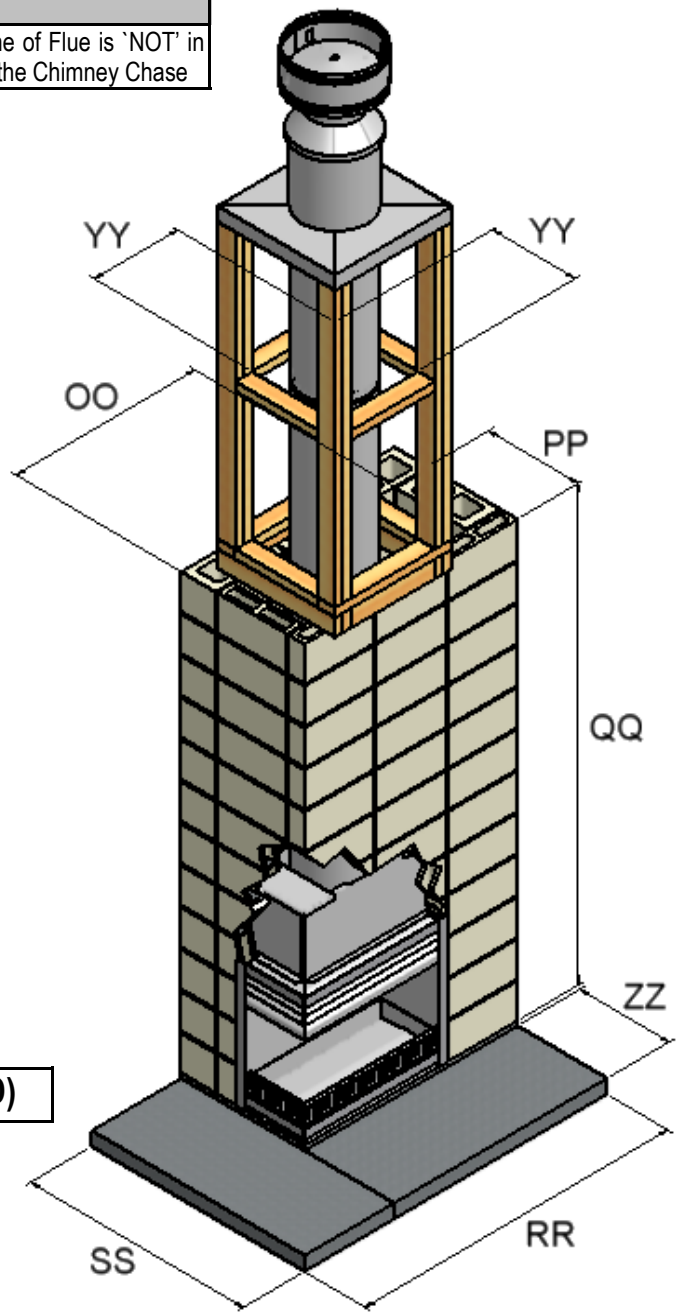

MINIMUM HEAT CELL BLOCK ALCOVE CLEARANCES

Note:
Centre Line of Flue is 'NOT' in Centre of Alcove

L/H (LEFT HAND)

Note:
Ensure that the Fire and Flue System is Installed before the alcove access is blocked off.
Block modules may vary to the drawing.

ACC HEAT CELL & CUT SIZES FROM PANELS for L/H SI 780TC

The ACC Heat cell is constructed around the firebox, using 75mm ACC (see attached minimum spec below).

(2400x600x75) Power Panels are required for basic heat cell construction as shown in detail "Firebox with ACC Surround".

*Note: If plastering the Heat Cell structure, it is recommended to use a fibreglass mesh with a latex plaster to minimise the chance of the plaster cracking. (See your plasterer for correct materials and applications).

Note:
ACC KITSET ASSEMBLY Details....
 When purchasing the "ACC Heat Cell Kit" the assembly Guide will come with the Kit.

L/H SI 780TC
 ACC Surround
 Assembly

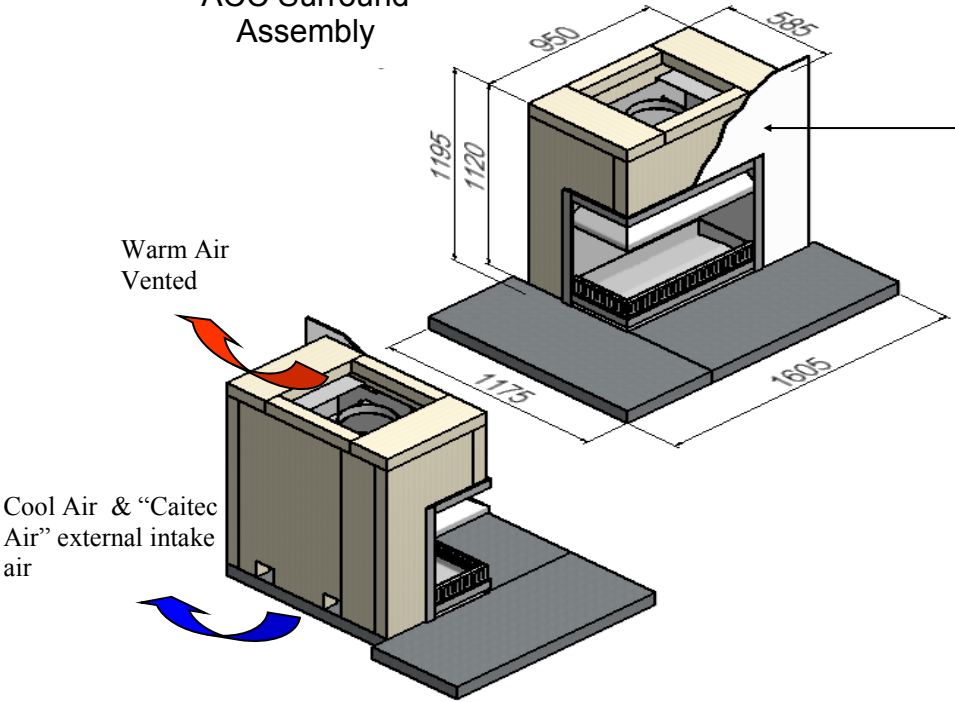

NOTE:
 9.5mm Promina
 Board lining on wall
 (Not Supplied)

HEBEL HEAT CELL & CUT SIZES FROM PANELS for R/H SI 780TC

R/H SI 780TC
 ACC Surround
 Assembly

NOTE:
 9.5mm Promina
 Board lining on wall
 (Not Supplied)

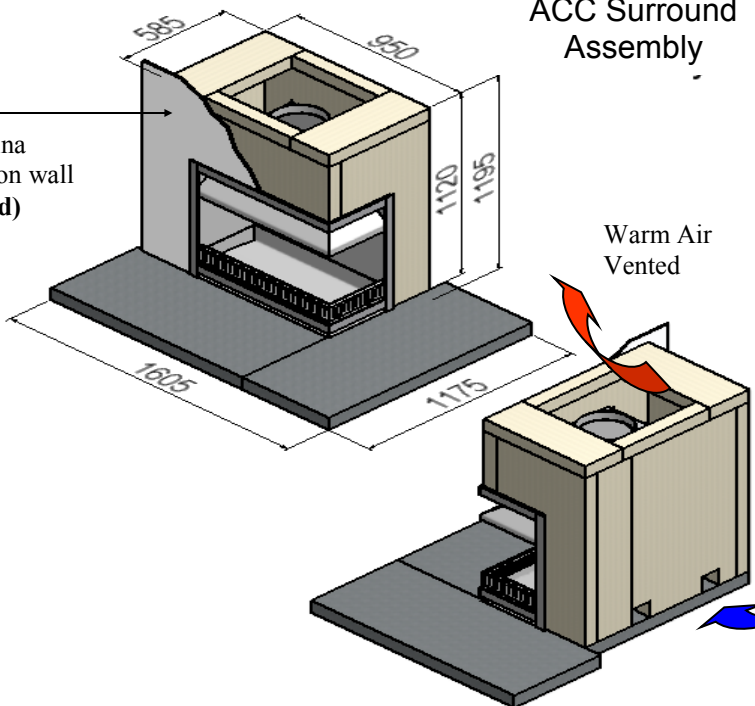

Note:
ACC KITSET ASSEMBLY Details....
 When purchasing the "ACC Heat Cell Kit" the assembly Guide will come with the Kit.

HEAT SHIELD ASSEMBLY

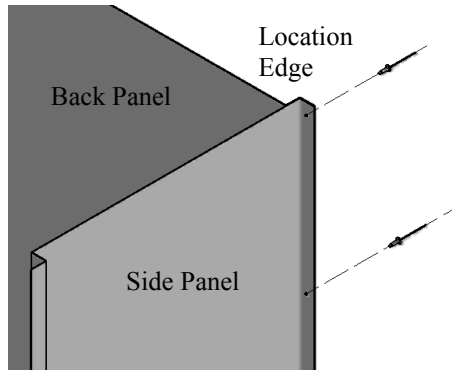
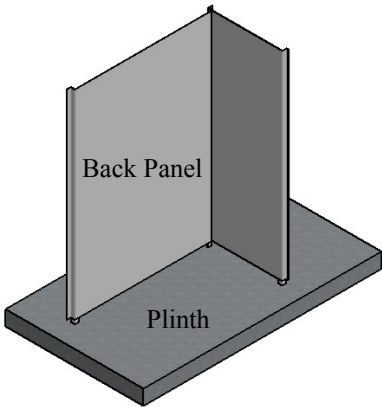

Heat Shield Assembly : Step 1

Method:
Clamp and secure 1 Side Panel to Back Panel.
Rivet panel together along location edge

Heat Shield Assembly : Step 2

Method:
1) Sit Firebox into position and fix down. Assemble adaptor and Flue System according To AS/NZS 2918:2001
2) Fix Front Top Panel & Side Top Panel Together First, then ensure the location tag is positioned at the top of Side & Back Panel. Clamp, secure and rivet Front Top Panel & Side Top Panel to Side Panel & Back Panel.

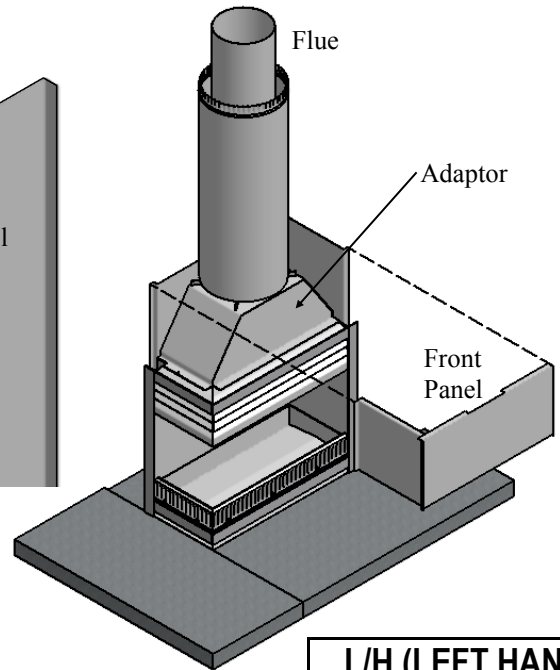
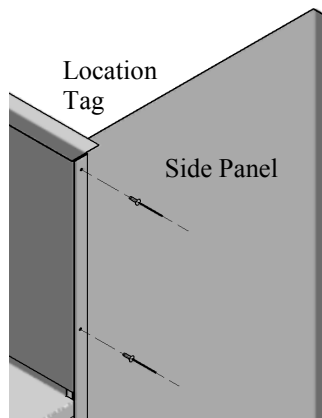

L/H (LEFT HAND)

Heat Shield Assembly : Step 3

Method:
Slide Flue Liner over Flue
Place Top Caps on the edge of the assembled side, Back & Top Front panels, clamp, secure And then rivet them together

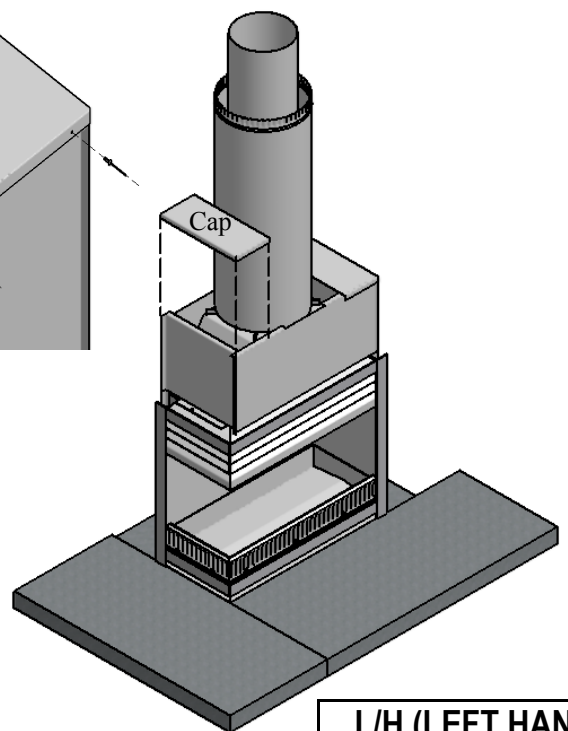
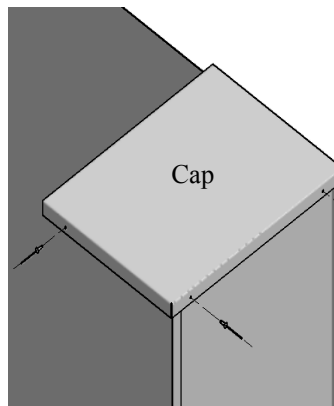

L/H (LEFT HAND)

Check List	Tick
Packet Screws	
Front Panel	
Side Front Panel	
Back Panel	
Side Panel	
Top Cap LH	
Top Cap RH	
Packed By :	

FLUE DETAILS DIMENSIONS

Minimum Flue Height	
Flue Height	3600
Measured From Top of Adaptor	B + G + 3600

Note: FLUE SYSTEMS Casing....
 Flue system may require to be Doubled lined to comply.
 Ref AS/NZS:2918:2001 4.3 Flue pipe casing

Flue details	No:	SI 780TC
Cowl	1	250
Cone	1	250
Top Spider	1	250
Flue Diameter	3	250
Liner Diameter	3	350
Spacer	3	250/350

NOTE: Ensure that a Standard Tested Warmington Flue system is used on the Warmington fires.

FLUE SYSTEM INSTALLATION GUIDE

This is a general installation guide only – Contact a “NZHHA Installer” for Installation Advice.
 See : www.homeheat.co.nz , choose “members” & pick your Area & Fire type (wood / Gas etc) this will provide you with a NZHHA Certified Installer (use the SFAIT Installers Only .)

1. Install the first length of Flue Pipe with the Crimped end down inside the Adaptor collar, ensure that the Flue Pipe is tight into the collar . Rivet the Flue in 3 places around the Adaptor collar. Place a spacer around the Flue Pipe approximately 150mm above the Adaptor Collar. Secure in position by tightening the Screw and Nut.
 2. Install the Second Length of Flue Pipe with the Crimped end down into the First Length and secure by Riveting in at least 3 places around the Flue Pipe joint .
 3. Install the First section of Flue Pipe Liner with the Crimped end up, over the Flue Pipe and over the spacer that is fixed to the Flue Pipe. This spacer will keep the Liner concentric around the Flue Pipe.
 4. Position Flue Spacers near the Flue Pipe joint for every length of “Flue pipe” and “Liner” .
- Repeat the Steps from 1 – 4 to the Installed required Height of the Flue System. The Flue System is to comply with AS/NZS 2918:2001 4.9.1

- a “the flue pipe shall extend not less than 4.6m above the top of the floor protector.”
- b “ the minimum height of the flue system within 3 m distance from the highest point of the roof shall be 600mm above that point.”
- c “the minimum height of the flue system further than 3 m from the highest point of the roof shall be 1000mm above the roof penetration.”
- d “no part of any building lies in or above a circular area described by a horizontal radius of 3 m about the flue system exit.”

1. **NOTE:** The last length of Flue Pipe needs to extend past the Liner so that when the “Top Spider” and the “Flashing Cone” are fitted, that the Top of the “Flashing Cone” and the “Flue Pipe” are **flush**, or that the “Flue Pipe” is **5mm lower** than the “Flashing cone”.
2. Fit the “Top Spider” into position, ensure that the legs of the Spider are fitted inside the Liner and that the spider is positioned hard down onto the Liner and Tighten with the Screw and Nut.
3. Place the “Flashing Cone” over the “Flue Pipe” and press hard down onto the “Top Spider”. (Note that the “Flue Pipe” and the “Flashing Cone” are either Flush or the “Flue Pipe” is 5mm Lower than the “Flashing Cone”.) Ensure that the “Flashing Cone” is clear for the venting from the “Liner” and the “Flue Pipe”.
4. Fit the “Cowl” over the Top & Inside of the Flue Pipe . The “Cowl” , “Flashing Cone”, and the “Flue pipe” can be secured to each other with the use of a Stainless Steel Self Tapping Screw. This will secure the “Cowl System” in high wind areas.
5. Flue Systems may require Bird Protection due to the Installation and locations, discuss this with your Installer for the best advice as this may not be supplied .
6. If the Flue System is Installed into a “Chimney Chase”, allow for Air Venting as close to the top of the Chase as possible , or allow Venting through the “Chimney Chase Flashing”. A “Venting Flashing Cone” and a 25mm gap around the Liner with a “Venting Flashing Cone-Spider” can be used. Ref to Page 11-12 in this Specification .

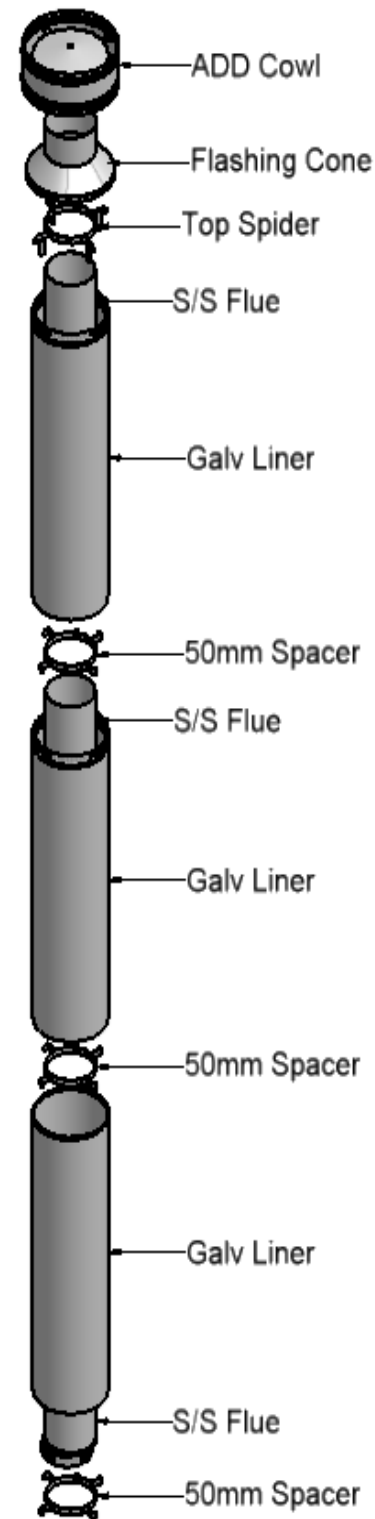

FLUE PENETRATION Vented through Alcove (Single lined Flue System)

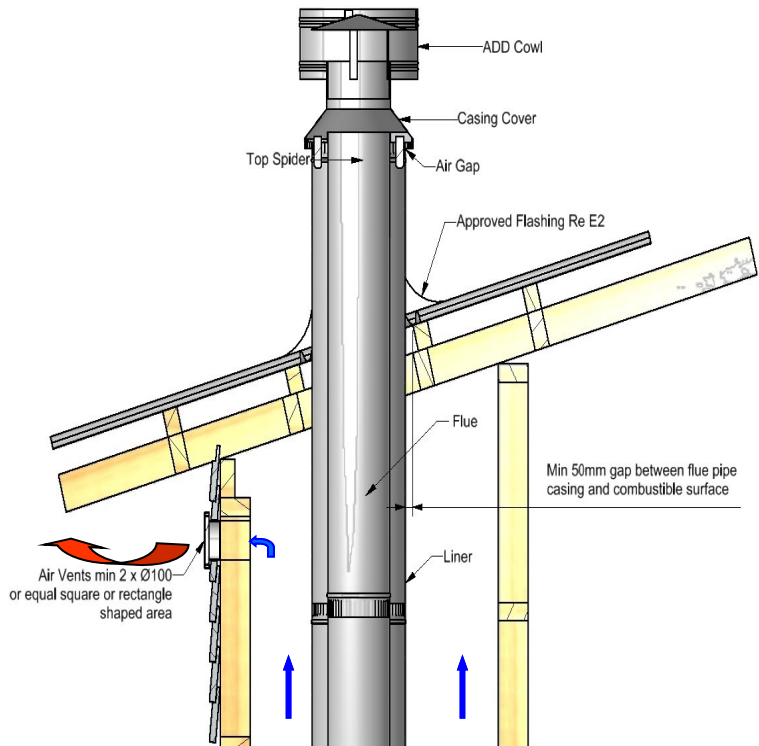

FLUE PENETRATION Vented through Alcove (Double lined Flue System)

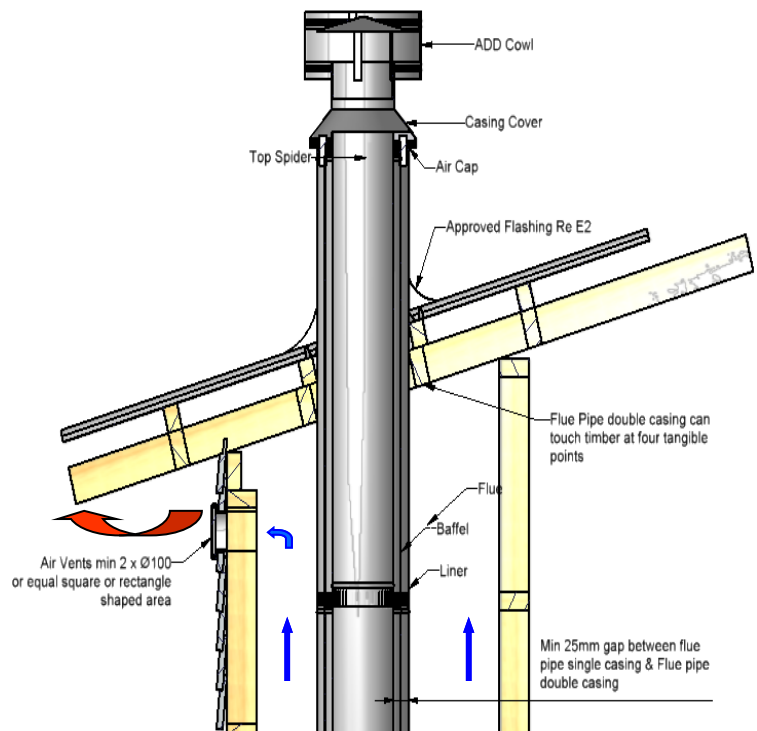

FLUE PENETRATION Vented through Top Flashing

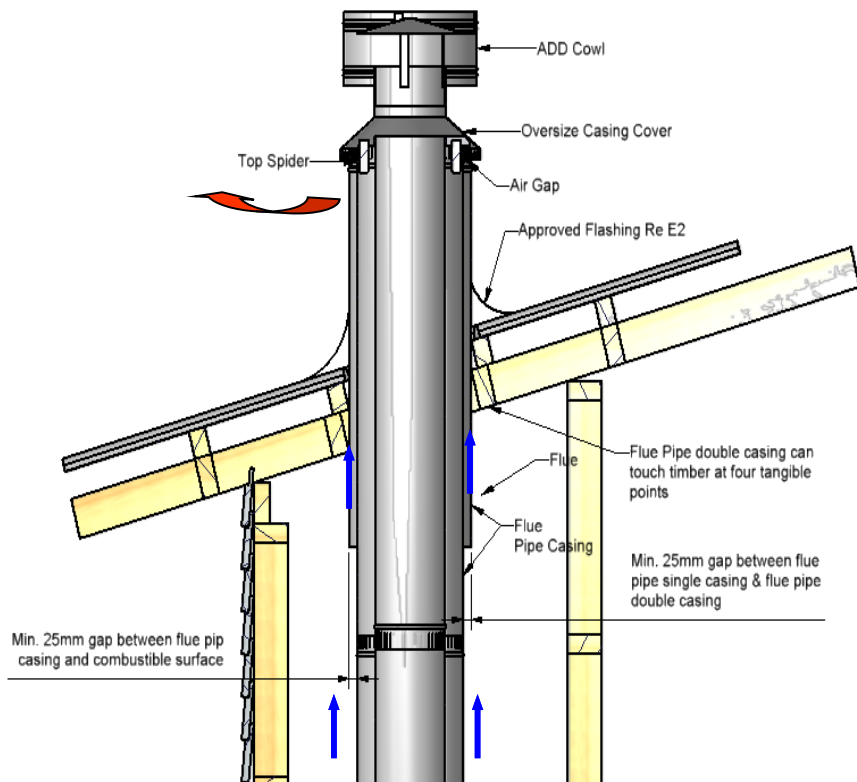

Note: FLUE SYSTEMS Casing....
 Flue system may require to be Doubled lined to comply.
 Ref ASNZS:2918:2001 4.3 Flue pipe casing

Note :

External Requirements
 Refer to AS/NZS2918:2001 4.9.1

Install Flue system to AS/NZS2918:2001

When using a rubber or Bitumen flashing (Butynol, Dectite) an Additional Flue pipe Baffle is required.

All external air vents & ceiling penetrations must be bird proofed with permanently fixed screens.

All flashing to comply with E2.

All external air vents and ceiling penetrations are to be Vermin and Rodent proof.

Test Report Number	Date of Report
04/1039	20 th July 2004
04/1040	20 th July 2004
04/1041	20 th July 2004

CHIMNEY CHASE FLASHING DETAILS **SETTING ADD COWL AND FLASHING CONE HEIGHT**

General Chimney Chase Flashing Lay Out

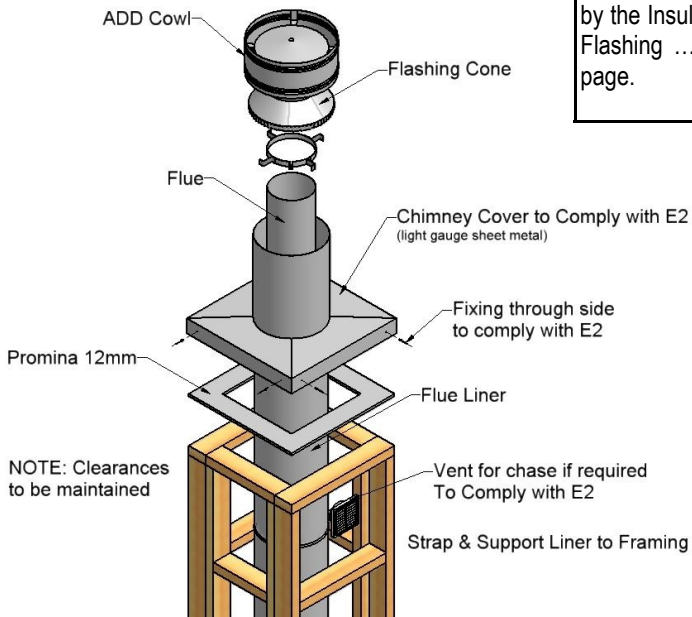

Note:
Flashing Spigot height is determined by the Insulation that is fitted under the Flashing ... See Details at bottom of page.

STEP 1

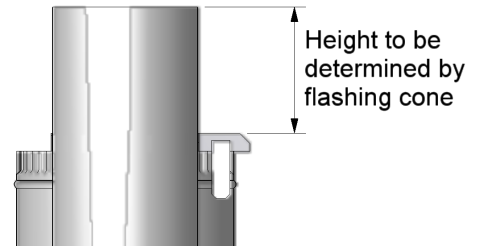

STEP 2

Flue 5mm Below Top Of Flashing Cone

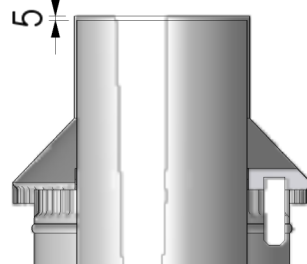

STEP 3

ADD Cowl Sits on Top of Flashing Cone, screw to secure

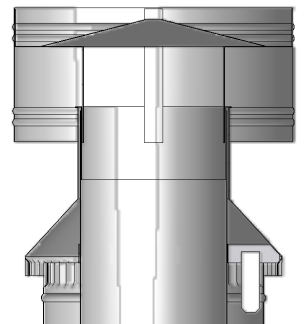

“CHIMNEY CHASE FLASHING” AND “AIR VENTILATION” OPTIONS :

VENTING THROUGH CHIMNEY CHASE

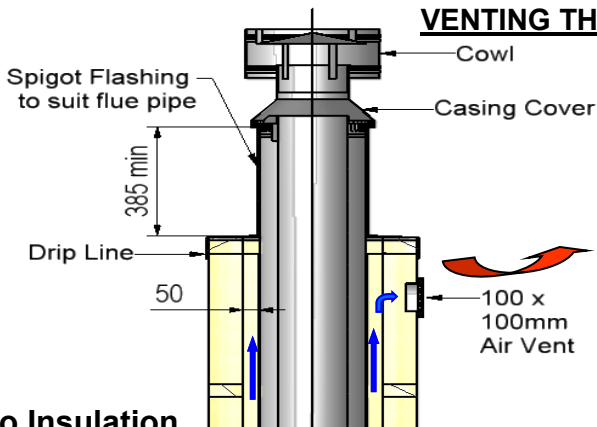

“No Insulation under flashing”

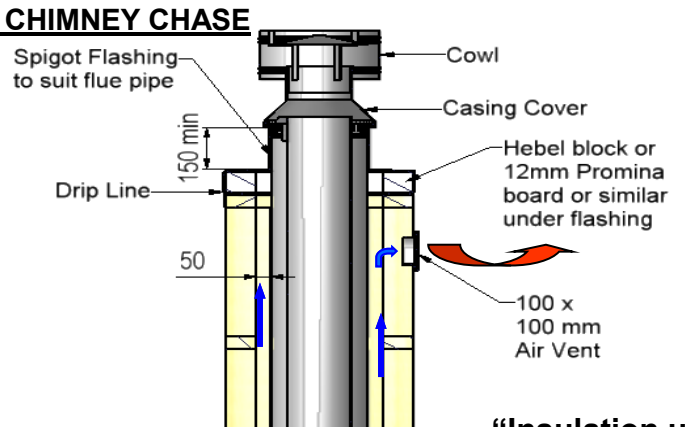

“Insulation under flashing”

VENTING THROUGH FLASHING

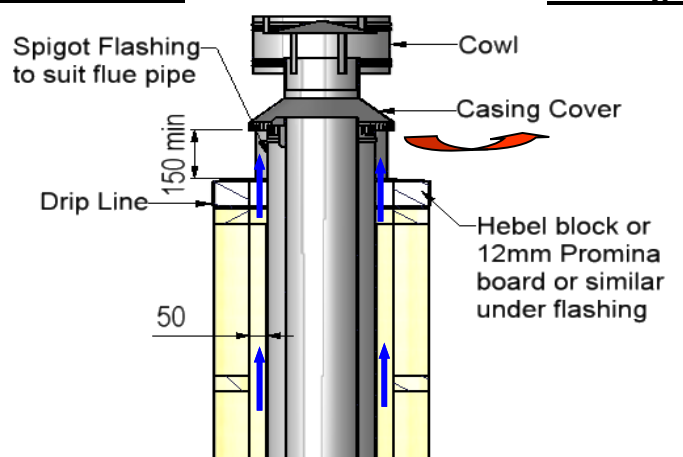
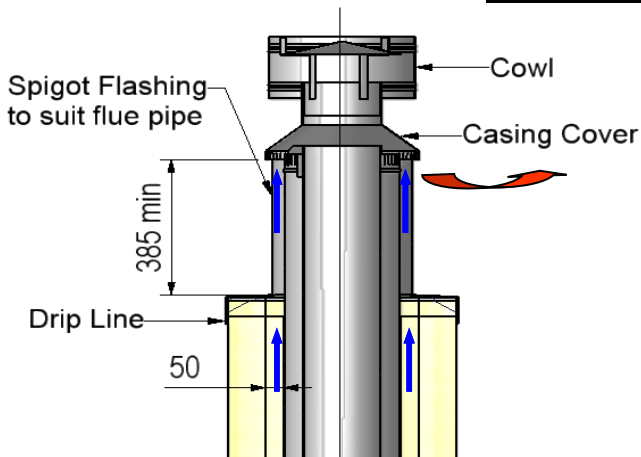

FLUE HEIGHT MINIMUM DETAILS

Note: FLUE SYSTEMS Casing....
 Flue system may require to be Doubled lined to comply.
 Ref ASNZS:2918:2001 4.3 Flue pipe casing

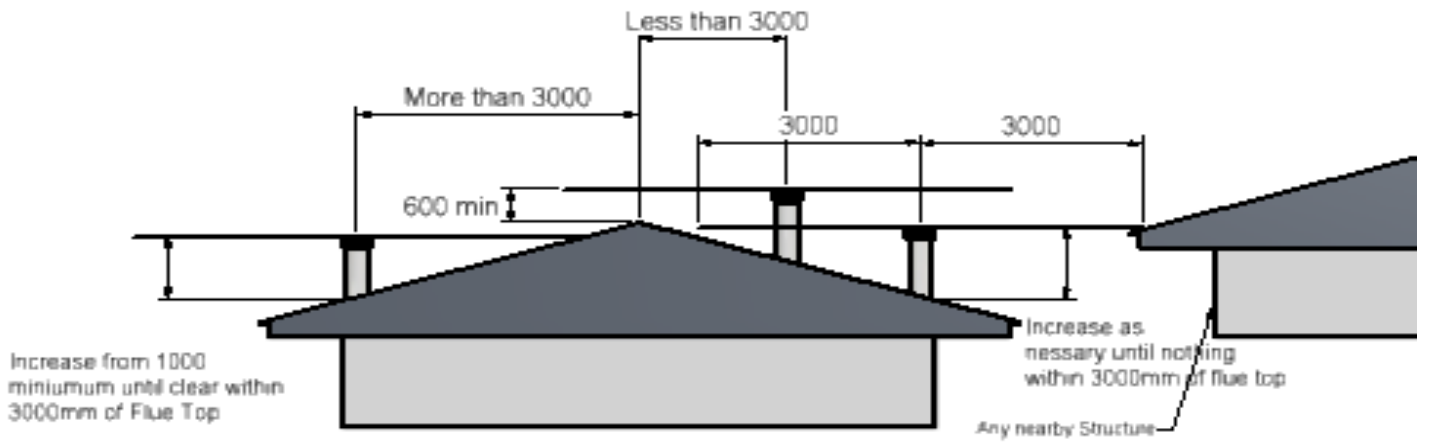

The flue exit is to comply to ASNZS 2918 : 2001

3D View

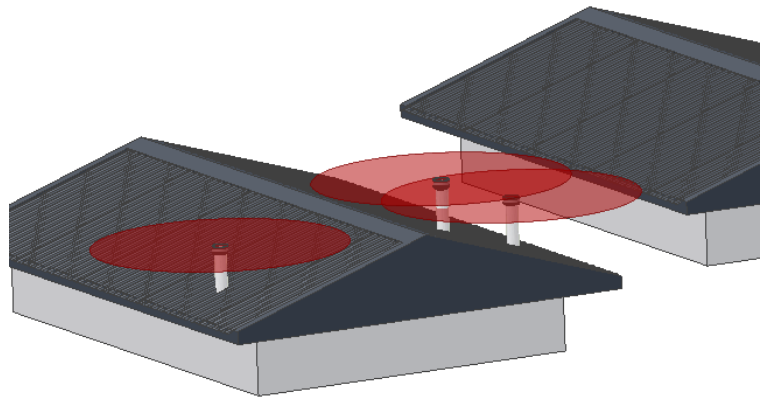

FRAME OUT AND TRIM OUT DETAILS FOR CHIMNEY CHASE

Option X – Singled Lined Flue System

Option Y – Double Lined Flue System

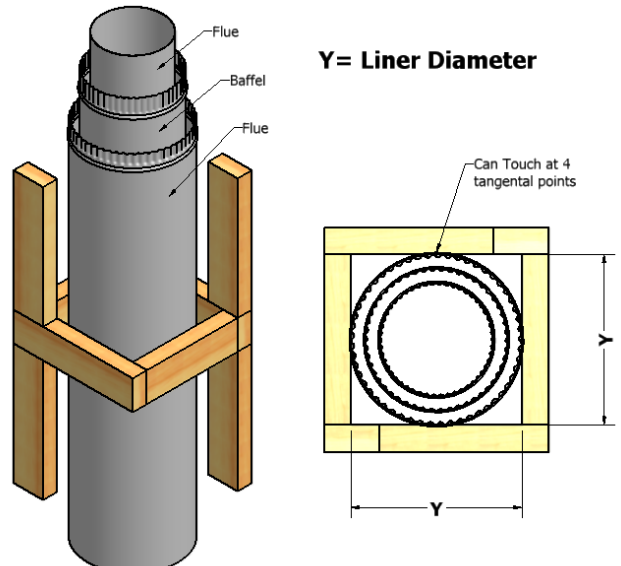
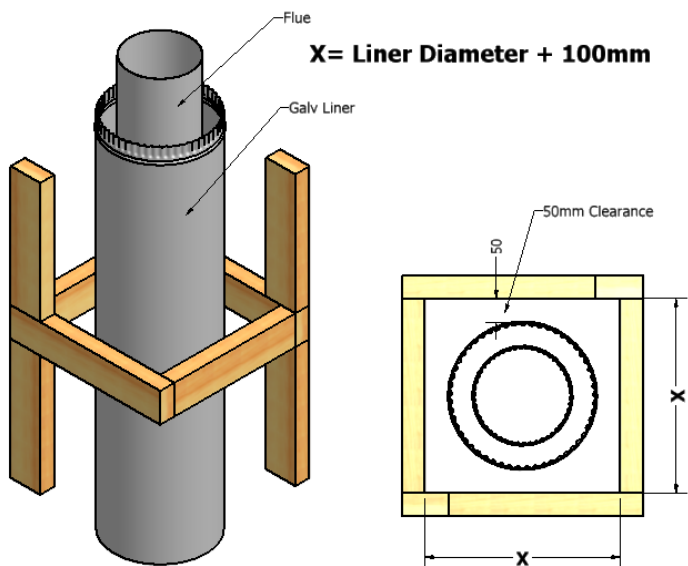

COMBUSTIBLE MANTLE CLEARANCES

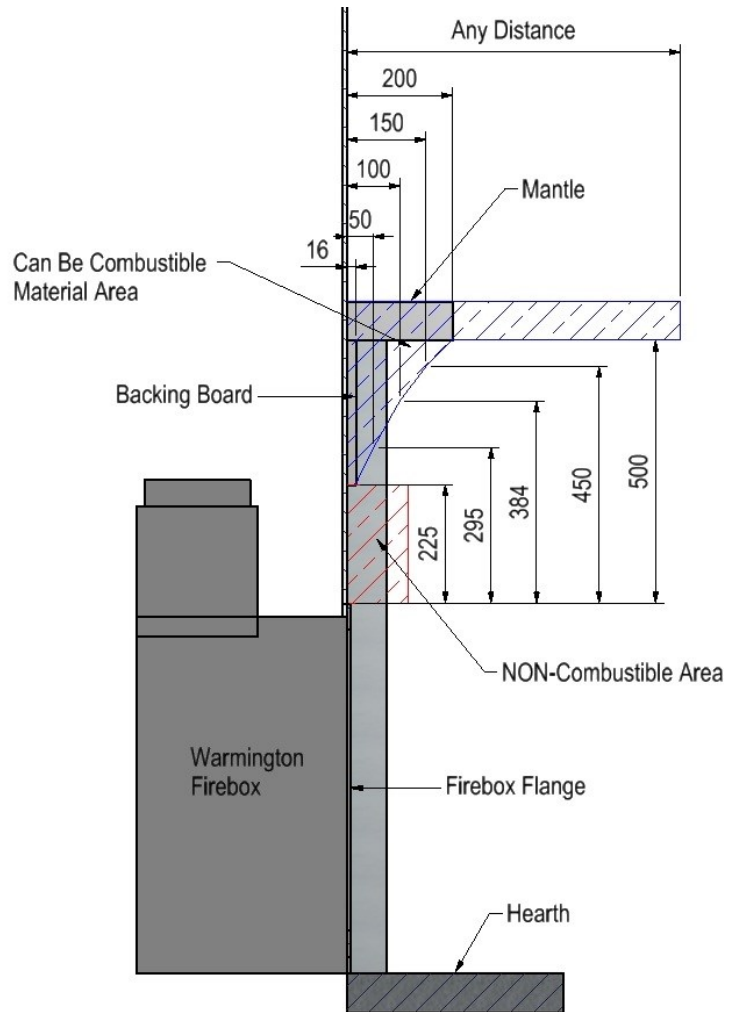
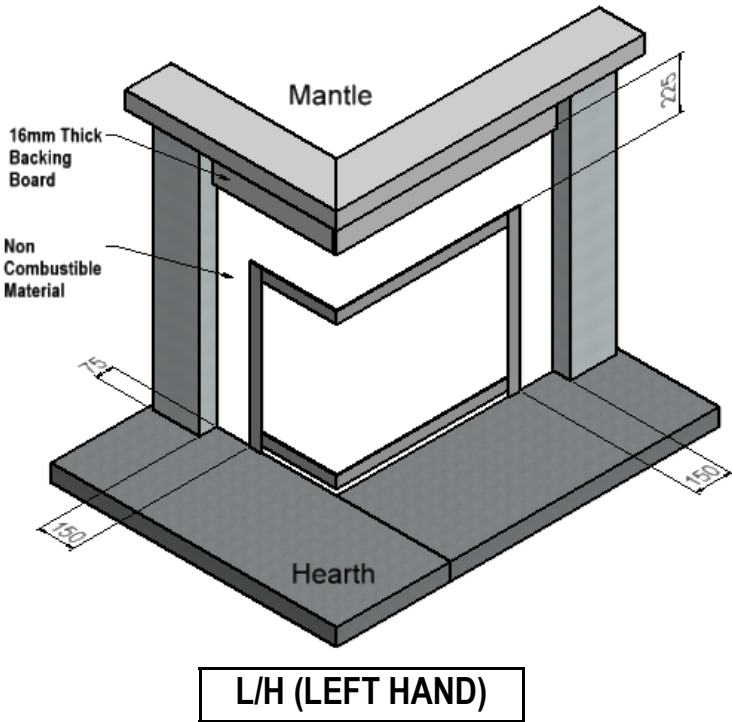

Note:
For Combustible Floors, a Minimum Hearth of 380mm (A) must be maintained.

HEARTH CLEARANCES VERSES HEIGHT

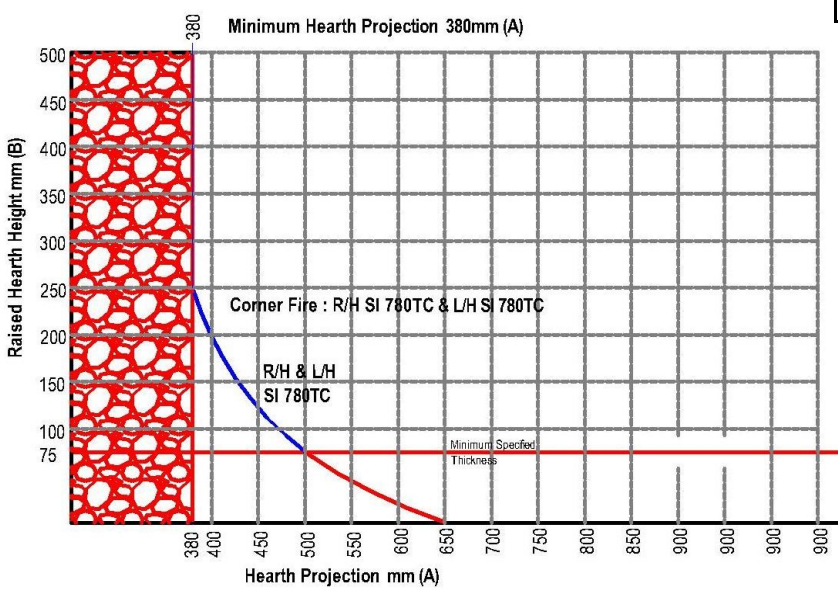

L/H (LEFT HAND)

NOTE : 9mm Pro-mina Fascia from Timber to the Fire. (Not Supplied)

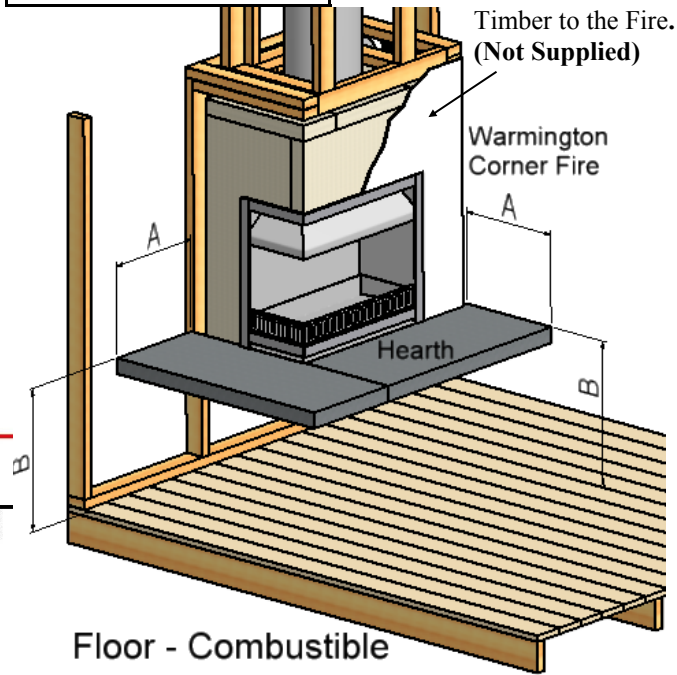

GENERAL NOTES : ASNZS 2918 : 2001**NOTES:**

- Fire Operation and Maintenance Instructions are available from www.warmington.co.nz to upload.
- Warranty—for full details on product warranties, contact your local Authorised Warmington Retailer.
- Correct installation, operation and maintenance must be maintained to comply with Warmington Warranty.
- The Appliance and Flue System must be Installed in accordance with ASNZS2918:2001 and the appropriate Building codes.
- The Flue system and Fireplace is to be swept annually or more frequently if required.

WARNINGS:

- **WARNING; ANY MODIFICATION OF THE APPLIANCE THAT HAS NOT BEEN APPROVED IN WRITING BY THE TESTING AUTHORITY IS CONSIDERED AS BREACHING AS/NZS 4013.**
- **WARNING; DO NOT USE FLAMMABLE LIQUIDS OR AEROSOLS TO START OR REKINDLE THE FIRE.**
- **WARNING; DO NOT USE FLAMMABLE LIQUIDS OR AEROSOLS IN THE VICINITY OF THIS APPLIANCE WHEN IT IS OPERATING.**
- **WARNING; DO NOT STORE FUEL WITHIN HEATER INSTALLATION CLEARANCES.**
- **WARNING; WHEN OPERATION THIS APPLIANCE AS AN OPEN FIRE USE A SPARK SCREEN.**
- **CAUTION:** THIS APPLIANCE SHOULD BE MAINTAINED AND OPERATED AT ALL TIMES IN ACCORDANCE WITH THESE INSTRUCTIONS
- **CAUTION:** THE USE OF SOME TYPES OF PRESERVATIVE-TREATED WOOD AS A FUEL CAN BE HAZARDOUS.

**NOTE: For Operation Instruction download from the website
www.warmington.co.nz**



**Industries 1994 LTD
PO Box 58652, Botany 2163, Auckland www.warmington.co.nz**