

Warmington Evoque 1300

Solid fuel burner, bricked fire Installation Instructions

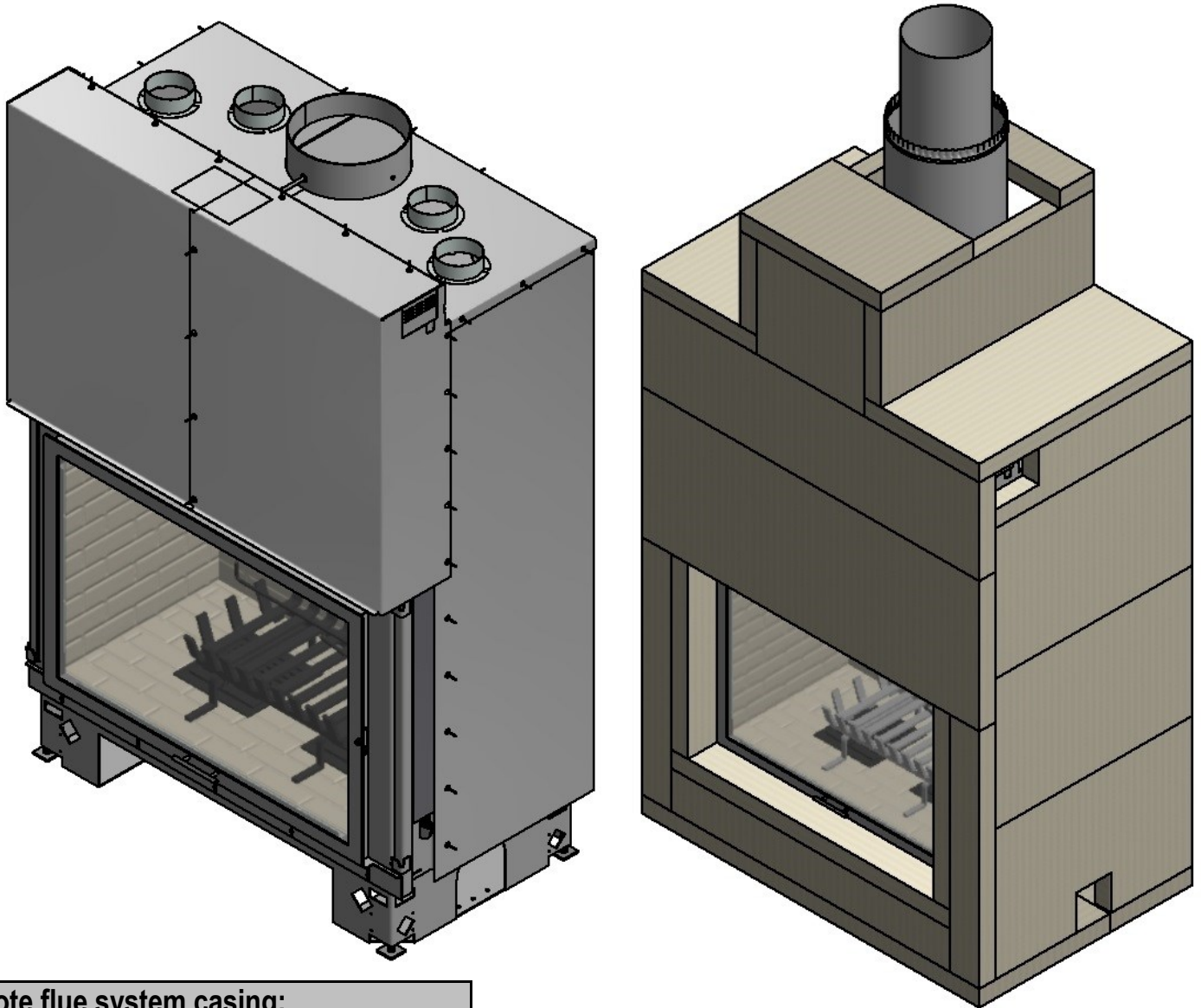

Note flue system casing:

Flue system may require to be doubled lined to comply to ASNZS:2918:2001 4.3 Flue pipe casing.

Fire, flue system and instructions to comply with ASNZS 2918:2001 & Building Code C1 Outbreak of Fire

Keep these Instructions for further reference. Ensure that you have the correct and current installation details for the Warmington Fire

Installation

The Warmington unit is to be installed by a certified Warmington installer or an Approved NZHHA Installation Technician.

IMPORTANT

Read all the instructions carefully before commencing the Installation. Failure to follow these instructions may result in a fire hazard and void the warranty

Due to continued product improvement, Warmington Ind LTD reserves the right to change product specifications without prior notification.

Components required for construction

(SUPPLIED SEPARATELY)

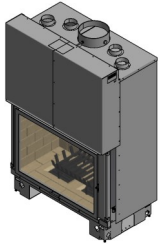
Supplied as traditional firebox	No:
Traditional firebox 	1

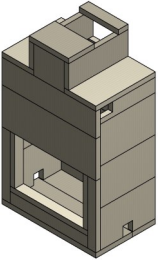
NOT supplied components are required for install	No:
Priced depending on requirements	
Autoclaved Concrete (ACC) heat cell 	1
Installation - Fire/flue kit/flashing	
Installation	
Council permit	

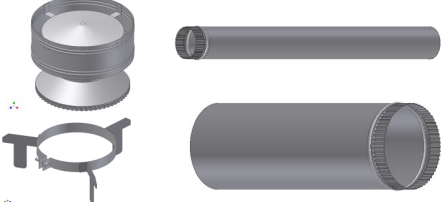
Supplied	No:
Priced depending on requirements	
Warmington flue kit 	1

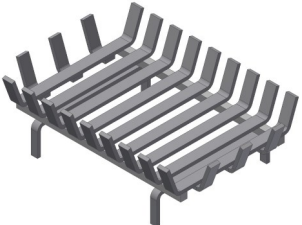
Supplied grate	No:
	1

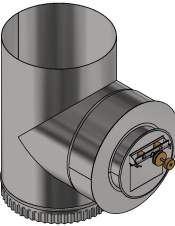
Downdraft diverter	No:
	1

Due to continued product improvement, Warmington Ind LTD reserves the right to change product specifications without prior notification.

POINTS TO CONSIDER PRIOR TO INSTALLATION

Location of the fire.

Open fires are better located at one end of a room or area, as they project the heat away from their opening.

The topography of the land.

The slope and position of the land in relation to the home has a bearing on how the wind will interact with the fire and flue system. Care needs to be taken to ensure that the flue termination is in the correct position to maximise performance.

The Prevailing wind.

Care needs to be taken to ensure that the flue termination is in the correct position as wind and gusts that hits the flue and cowl system may overcome the cowl and draft back down the flue into the home. This can be a combination of downdraft and high pressure.

Hearth and plinth:

The height of the hearth off the floor. The finishing that is to be used on the hearth is to be allowed for at the design stage.

Note: ensure air intake at base of firebox is not blocked or restricted.

Positioning of the flue system:

There is a maximum distance that an offset flue can be installed. Reference to AS/NZS 2918:2001.

Flue and fire clearance:

To be maintained to the manufactures instructions and/or comply with appropriate standards and building codes.

Pressure differential, venting and external air into the building:

All fires need air to burn and draw correctly, Kitchen Fans, Air Conditioning units, High Wind Zones, Naturally forming Draft spaces, can all have an effect on the pressure difference from inside the building to the outside. A lower pressure in the building may induce a draft down the flue system and back into the building causing the fire to smoke or spill into the building. **Care needs to be taken at the design and installation stage to adequately vent the building, or some mechanical system to ensure that there is always a neutral or positive pressure at the fireplace and a negative pressure at the flue outlet.** This will ensure that the draft in the flue system is always to the outside.

Wind Noise:

You may encounter wind noise in some installations. It is recommended to use an enclosed chase with a chimney pot to help reduce noise. There will always be some noise from the flue systems of all fireplaces.

Installation Notes:

Due to the expansion and contraction of metal fireplaces a 3mm gap between the flange and the finished surround should be maintained.

INSTALLATION ORDER OF OPERATIONS installation is not provided

Prior to construction and installation IMPORTANT NOTES:

Install to AS/NZS 2918:2001.

Install to manufacture's specifications.

All new installations require a permit.

For special requirements concerning materials (timber mantle and surrounds) within close proximity of Warmington products, please contact your local Warmington technical consultant or designated installer.

Stage 1: Frame construction procedure by builder.

Mark out flue centre on floor.

Mark out heat cell clearance requirements.

Construct plinth only, to required height.*

Stage 2: Install procedure by certified "Warmington Installer" or see www.homeheat.co.nz go to "members" & follow instructions. For an NZHHA certified SFAIT installer.

Fit fire to plinth.

Fit adaptor to firebox.

Construct Autoclaved Concrete (ACC) enclosure around the firebox.

Fit flue system.

Fit cowl and flashing system.

Stage 3: Finishing procedure by builder.

Construct hearth to required thickness.*

Finish Autoclaved Concrete (ACC) enclosure and hearth to customers requirements (e.g. paint/tiles).

Close in Autoclaved Concrete (ACC) enclosure and chimney chase (if in timber alcove).

* Note: A certified installer can also install hearth and plinth.

Ensure that the Warmington and flue system is swept annually or more frequently if required. To sweep flue and firebox:

Cover front of fire with sheets, or keep door closed during sweeping.

Remove cowl from top of chimney.

Sweep from the top, down the flue.

Remove all soot and ash.

Ensure cowl and bird protection is clean and replaced.

Visually inspect fireplace and flue system.

Due to continued product improvement, Warmington Ind LTD reserves the right to change product specifications without prior notification.

EVOQUE FIREBOX DIMENSIONS

Description		Evoque
Firebox Width	A	1216
Widest Part with Rail Burner	AA	1385
Firebox Height	B	1790
Firebox Depth	C	620
Door Width	D	1100
Door Height	E	750
Adaptor Height	F	740

Minimum Flue Height	
Flue Height	3600
Measured From Top of Adaptor	B + F + 3600

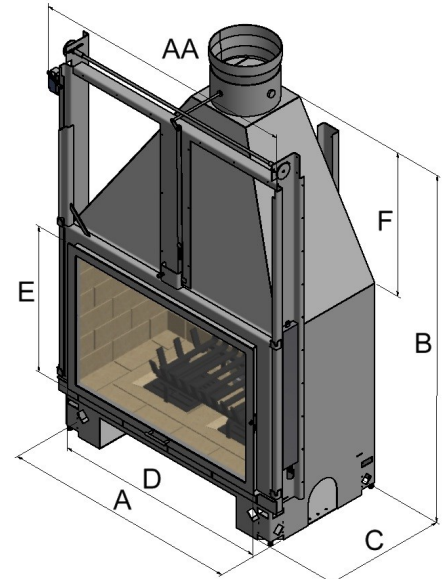
ACC HEAT CELL DETAILS DIMENSIONS

Description		Evoque
Heat Cell Width	G	1552
Heat Cell Height	H	2170
Heat Cell Depth	I	980
To Centre of Flue	J	624
Flue Diameter	K	300
Liner Diameter	L	400
Heat Cell Clearance Width	M	1602
Heat Cell Clearance Depth	N	1105
Heat Cell Clearance Height	O	2420
Chimney Clearance Height	OO	1500

Note: Chimney Chase

No combustible material installed above the fire or in the chimney chase below 1500 mm from the top of the fire.

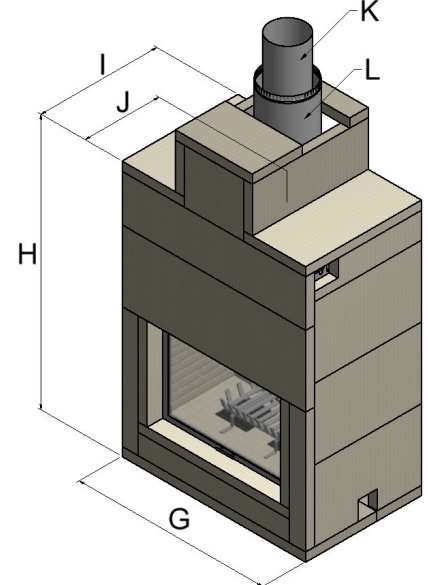

ACC HEARTH & PLINTH DIMENSIONS

Description		Evoque
Hearth Width	P	1552
Hearth Projection	Q	600
Plinth Width	R	1552
Plinth Depth	S	980

See next Page 5 for Plinth & Hearth

Check List	
Firebox	
Grate	
Ash Pan & Ash Tray	
Draft Diverter	
Bricks	
Packed by	

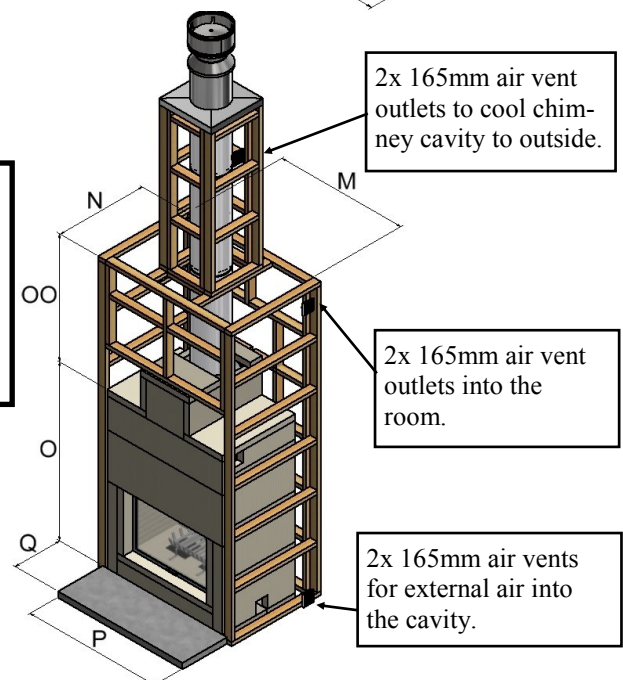
NOTE: Access panels for servicing and adjusting the downdraft diverter and sprockets needs to be installed.



Due to continued product improvement, Warmington Ind LTD reserves the right to change product specifications without prior notification.

ENCLOSURE (WITH ACC HEAT CELL)

Description		Evoque
Hearth Width	P	1675
Hearth Projection	Q	600
Block Clearance Width	R	1610
Block Clearance Depth	S	1200
Block Enclosure Height	T	2390
Distance to centre of flue	U	714

NOTE: WITH BLOCK HEAT CELL Timber Framing can be in direct contact with brick alcove.

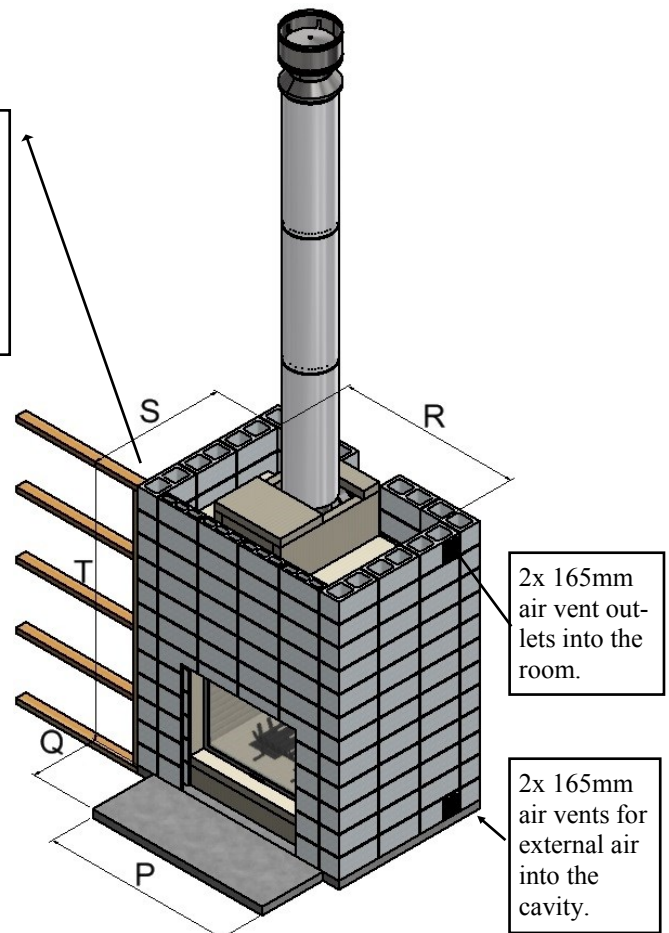

GRATE

Description		GRATE
Grate Depth	V	410
Grate Width	W	605
Grate Height	X	195

Important Note
Do not load the fire with more than 5kg of softwood.

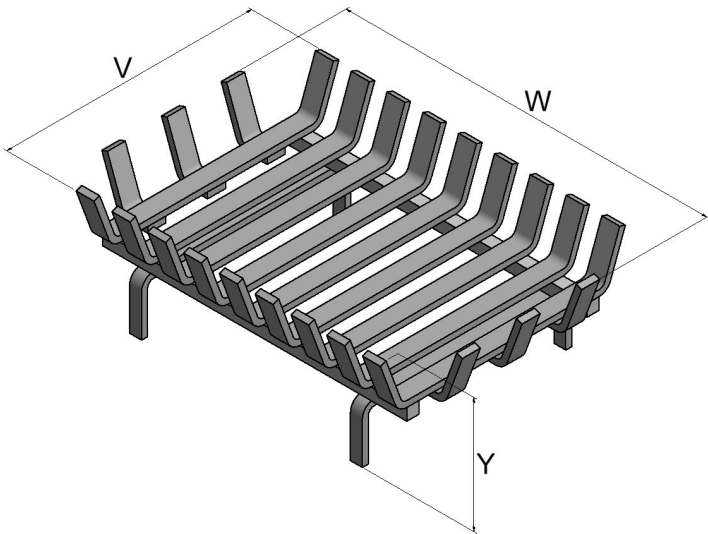

Important Note
The fire has to be installed and run with the supplied Warmington grate to comply with AS/NZS 2918:2001

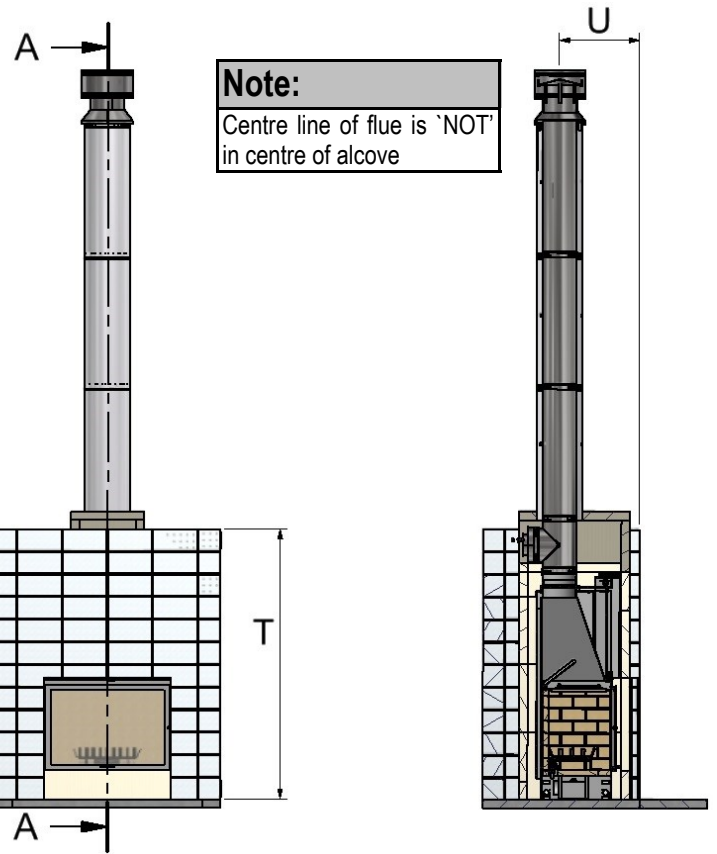

Due to continued product improvement, Warmington Ind LTD reserves the right to change product specifications without prior notification.

FIREBOX INSTALLATION

This is a general installation guide only – contact a “NZHHA Installer” for installation advice or go to www.homeheat.co.nz then select Members & follow instructions, to find a certified NZHHA SFAIT installer.

1. All the dimensions are minimums
2. Fit the plinth into position in the cavity. If onto a wooden floor ensure that an insulating plinth is fitted as per specifications. **Ensure that the plinth is elevated to allow for finishing on the hearth (see hearth and plinth details).**
3. Fit the firebox into the cavity. Bolt the fire box to the plinth or through to the floor with the bolting point provided on the left and right hand side of the firebox or drill holes through base for bolts (seismic restraints bolts not provided).
4. Install the flue system. Ensure that the flue system comply to the latest AS/NZS 2918:2001.
5. Fit the Autoclaved Concrete (ACC) heat cell around the fire. A general minimum lay out is shown in this specification.

HEARTH & PLINTH CONSTRUCTION DETAILS

IMPORTANT NOTE:

Note: hearth and plinth construction.

For combustible flooring an insulating hearth and plinth of 75mm Autoclaved Concrete (ACC) is required.

Plinth to be off set above hearth by the hearth finishing (e.g. tiles/granite/plaster/etc.)

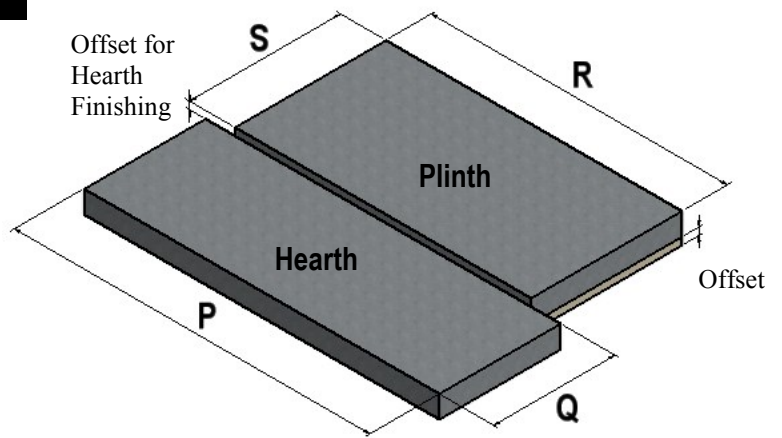

***Note: If solid plastering the heat cell structure, it is recommended to use a fibreglass mesh with a latex plaster to minimise the chance of the plaster cracking (see your plasterer for correct materials and applications).**

HEARTH PROJECTION

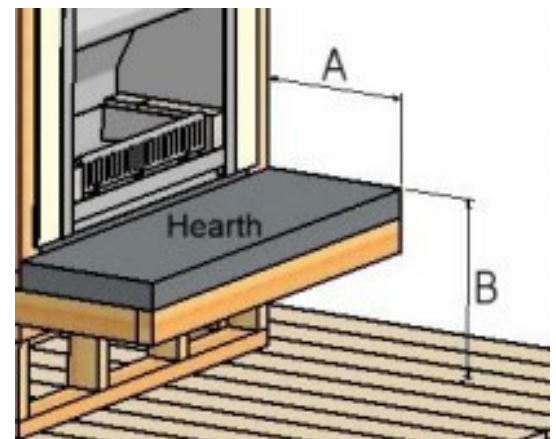
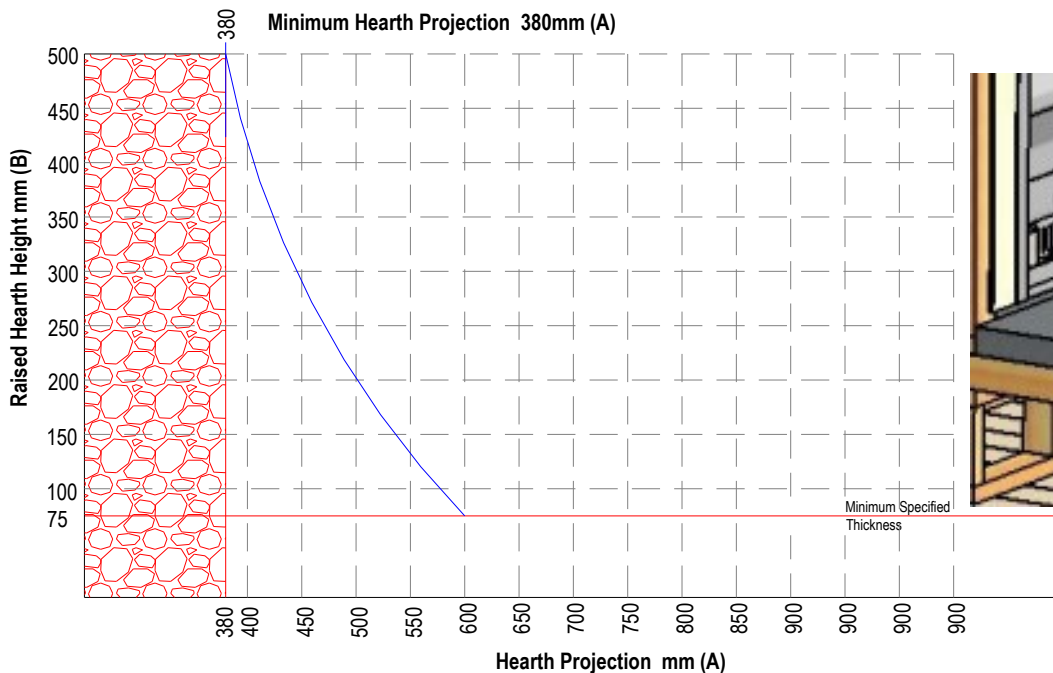

Due to continued product improvement, Warmington Ind LTD reserves the right to change product specifications without prior notification.

BAFFLE POSITION

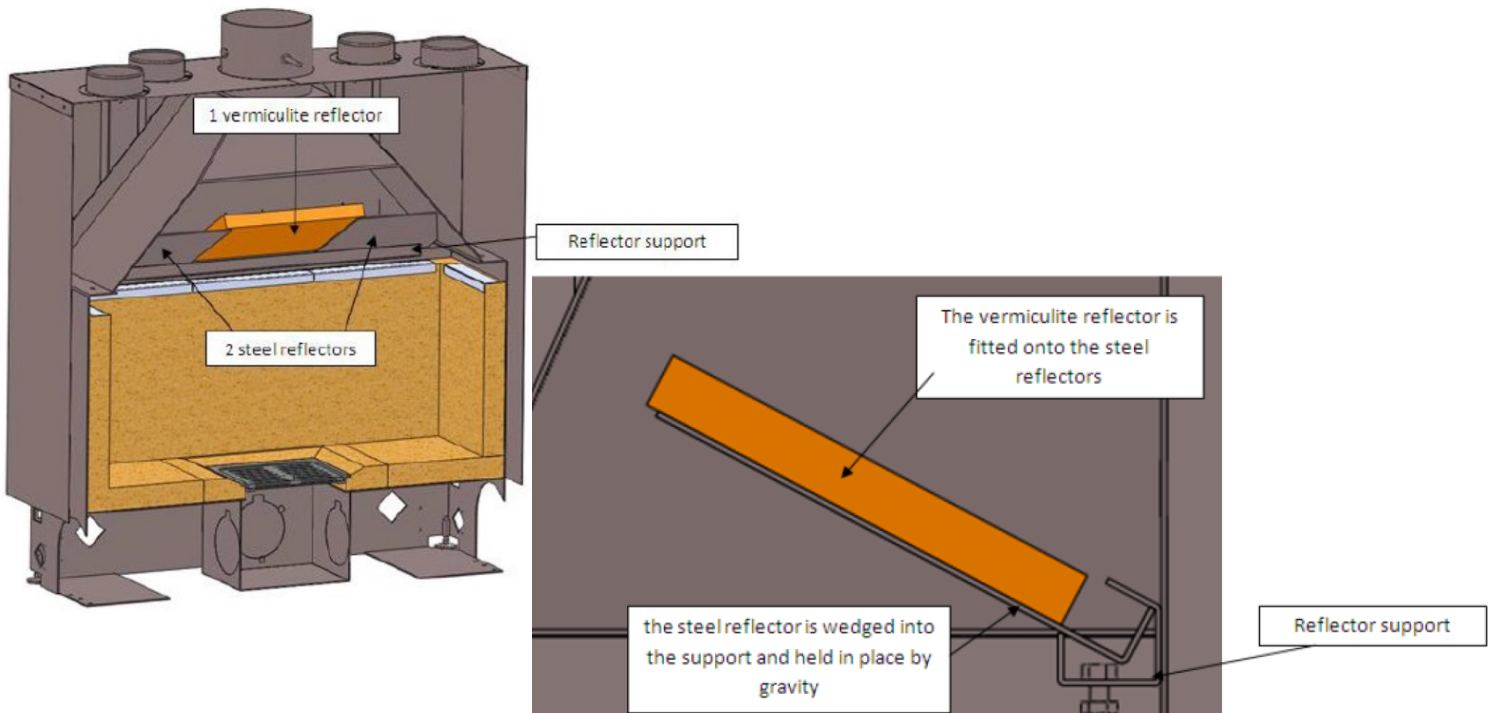

CHAIN AND SPROCKET ACCESS CHANNEL

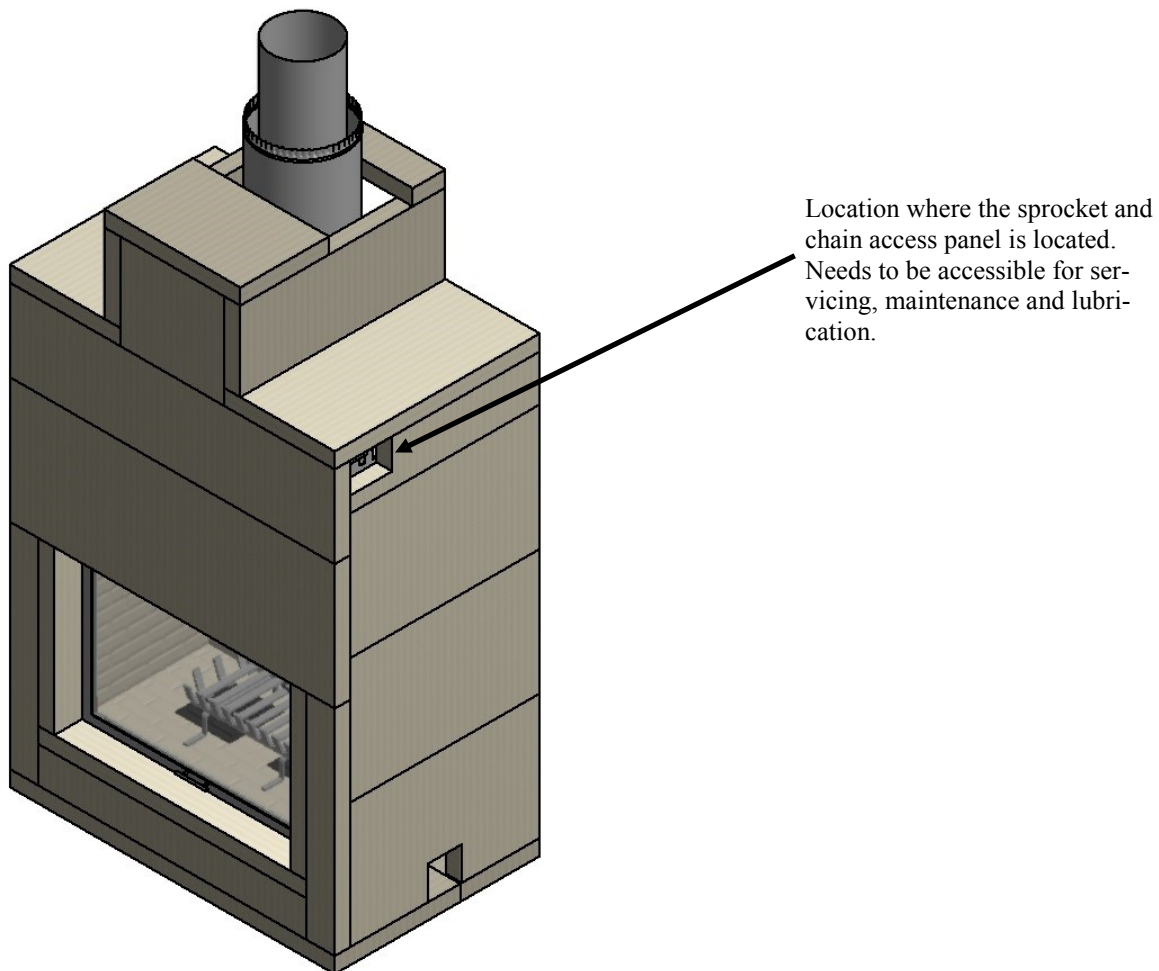

Due to continued product improvement, Warmington Ind LTD reserves the right to change product specifications without prior notification.

DOWNDRAFT DIVERTER

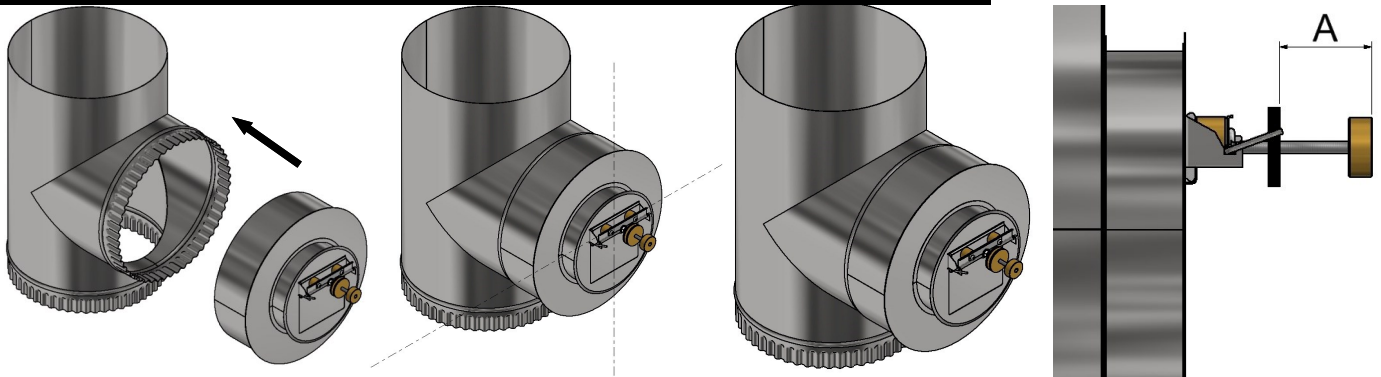

Installation onto a stainless tee-flue:

1. Set the draft diverter on the tee branch by fitting it as tight as possible to the tee.
2. Check that the valve is perfectly horizontal using a spirit-level, and rivet to the tee flue.
3. The adjustment of the draft diverter depends on the draft. With a standard 3.6 metre of flue dimension A is set to 12mm. If extra lengths of flue is installed the "A" distance in mm corresponds on the pressure in PA, 1mm = 1Pa, this can be approximated by reading the chart below. Adjust the counter weight to the required distance by rolling it on its axis then fix it by tightening the brass disks against each other, note that the thick brass disk always is at the end of the rod. To unlock the draft stabiliser, turn the stop in clockwise direction. *This is done to keep a stable draft in the flue; more draft will require less counterweight to regulate the draft.*

Flue Height	Pressure	A
3.6 metre	12 Pa	12 mm
4.2 metre	14 Pa	14 mm
4.8 metre	16 Pa	16 mm
5.4 metre	18 Pa	18 mm
6.0 metre	20 Pa	20 mm
6.6 metre	22 Pa	22 mm
7.2 metre	24 Pa	24 mm

Note: Positioning

The position of the draft diverter is set to the orientation that ensures the best and easiest access to the opening face.

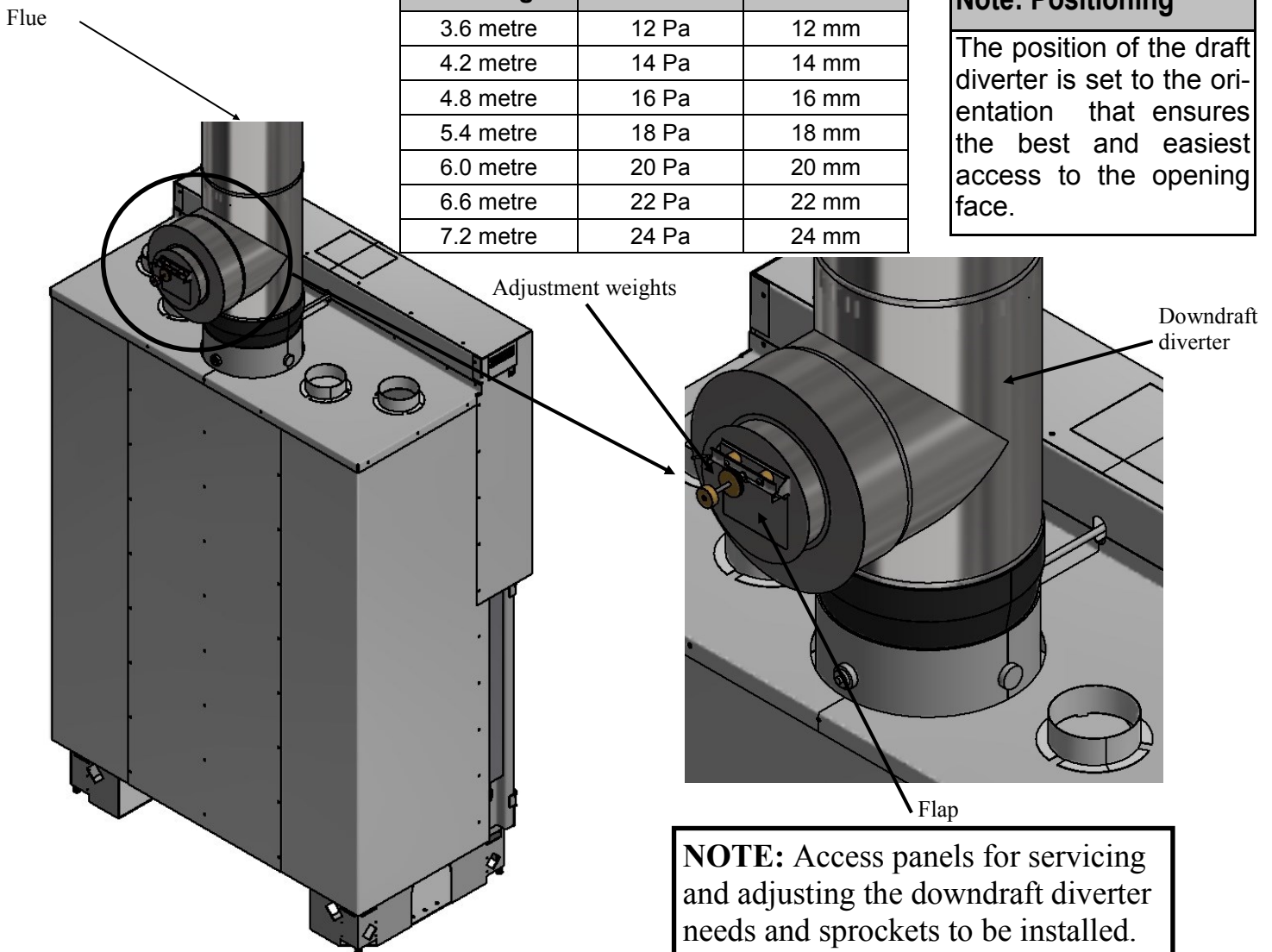

Due to continued product improvement, Warmington Ind LTD reserves the right to change product specifications without prior notification.

AIR INTAKE

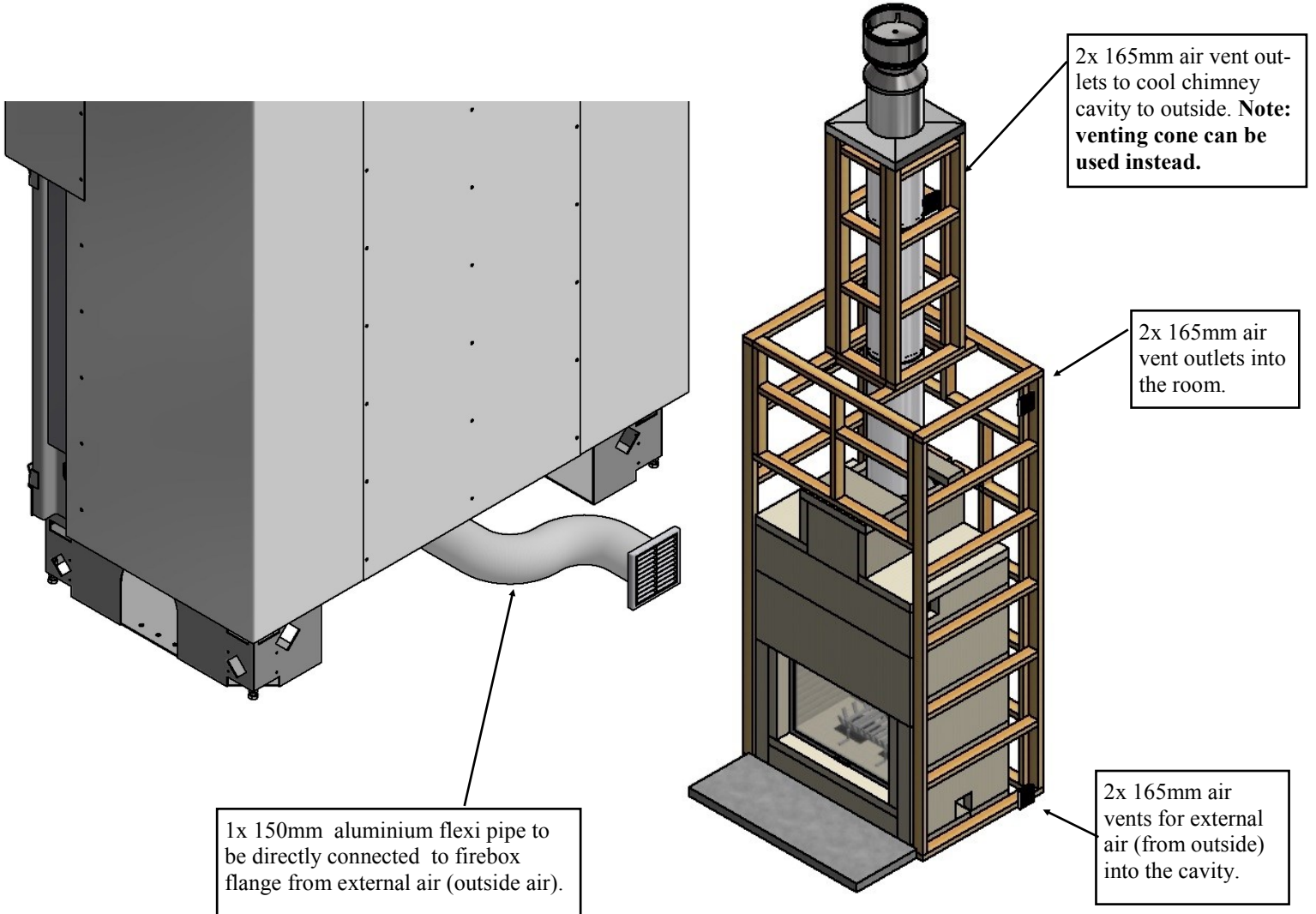

ACCESS PANNELS

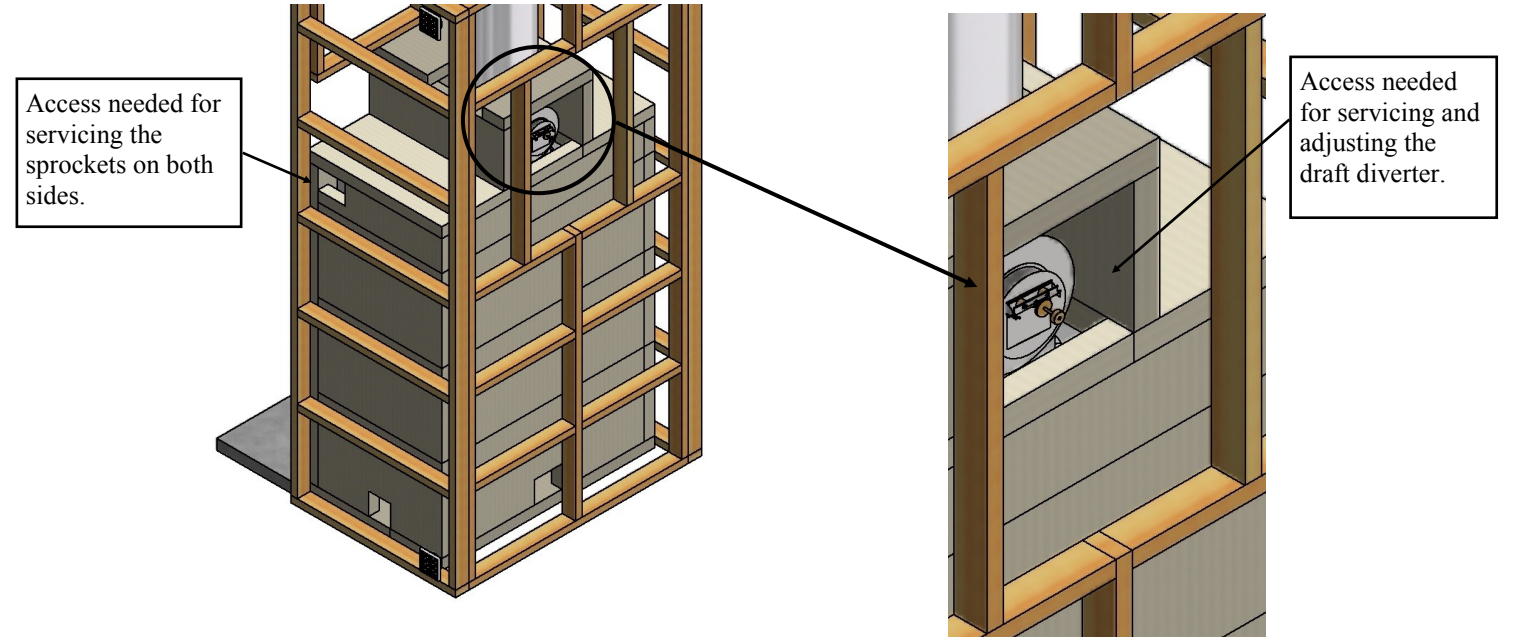

Due to continued product improvement, Warmington Ind LTD reserves the right to change product specifications without prior notification.

VENTING CONCEPT

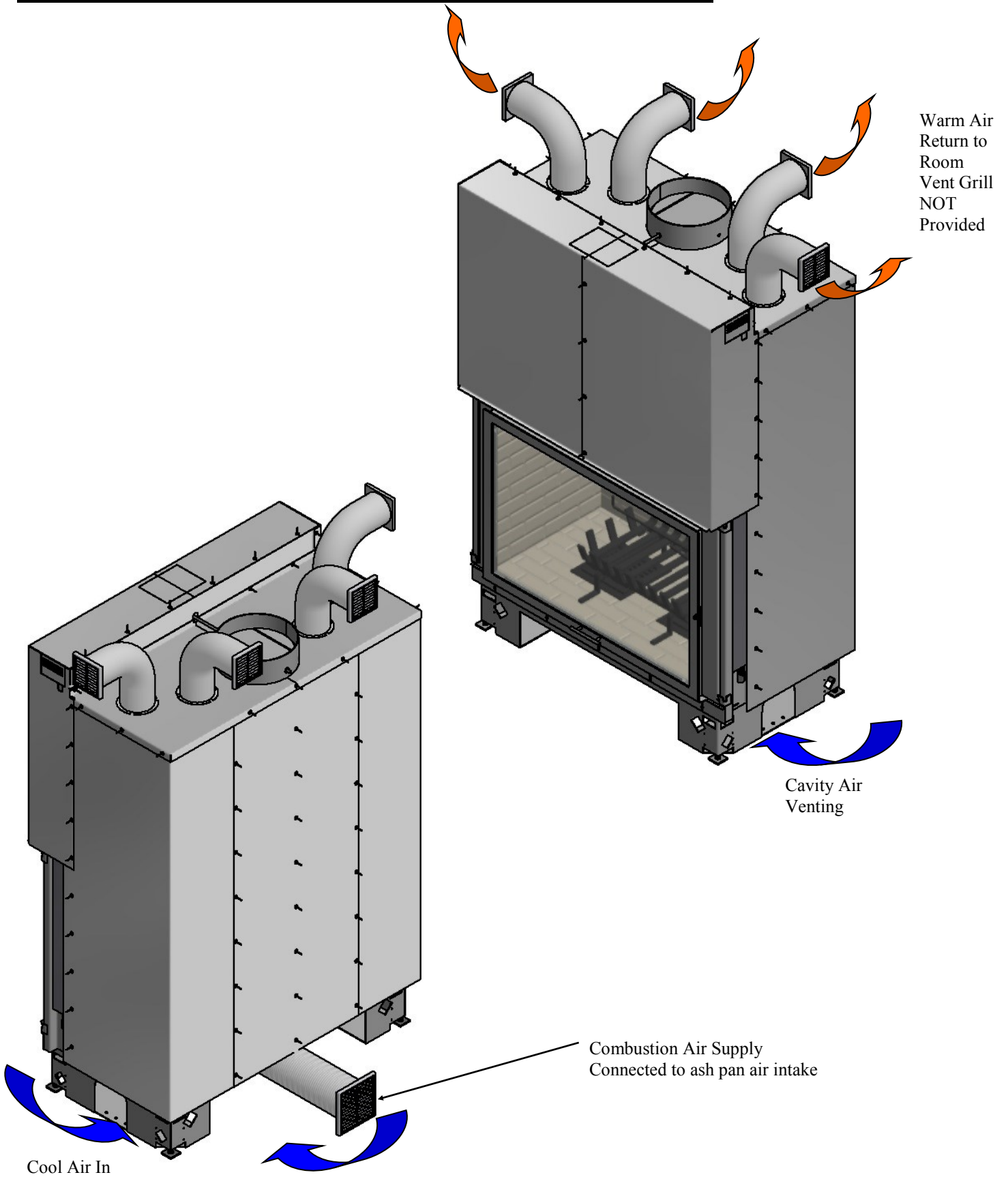

Due to continued product improvement, Warmington Ind LTD reserves the right to change product specifications without prior notification.

AUTOCLAVED CONCRETE (ACC) HEAT CELL
ACC KITSET ASSEMBLY details

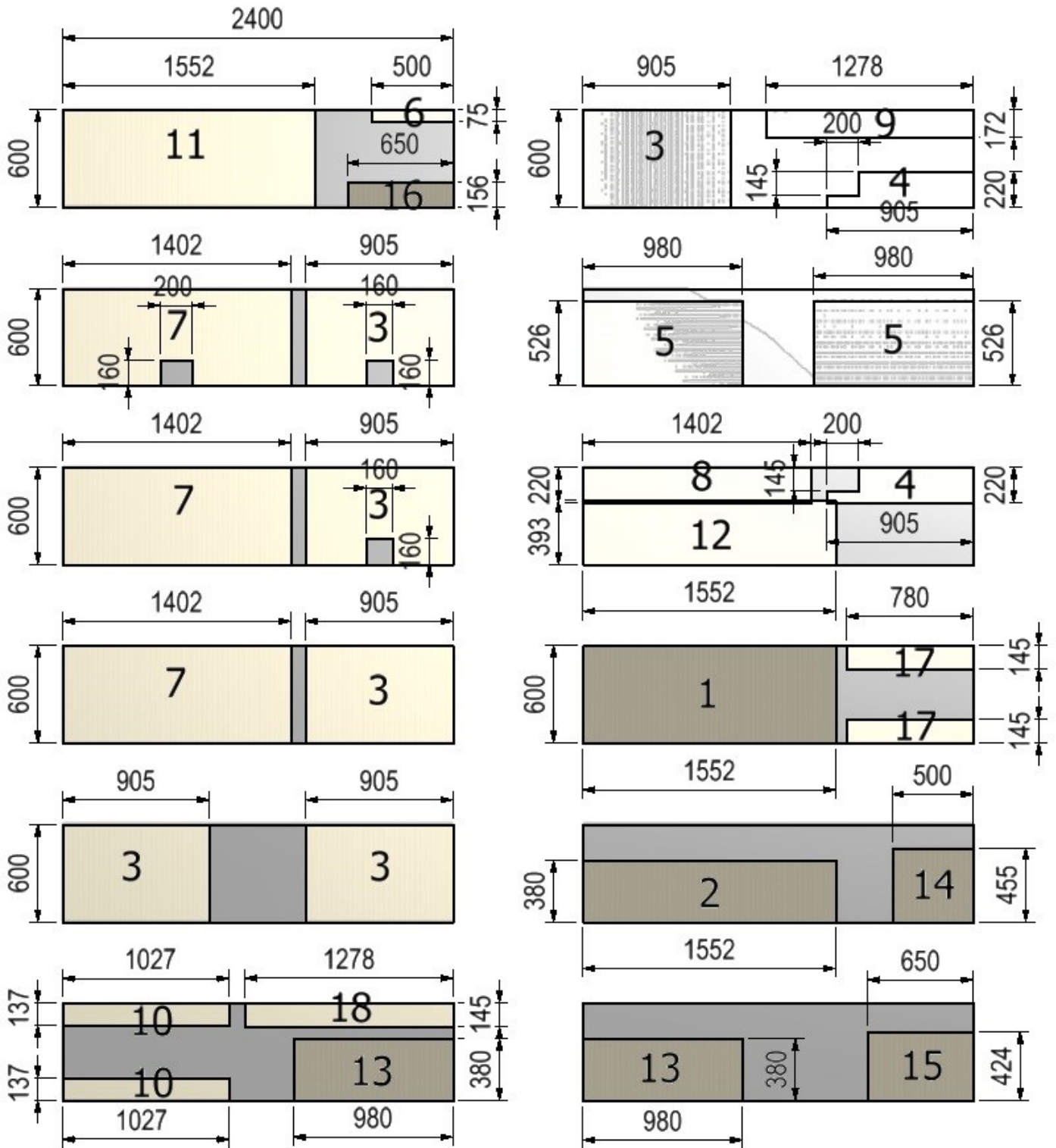

The ACC heat cell is constructed around the firebox, using 75mm ACC (see attached minimum spec below).

Power panels (2400x600x75) are required for the basic heat cell construction as shown in detail "Firebox with ACC Surround".

Visit the Warmington website for "ACC" instructions (download pdf at www.warmington.co.nz).

Due to continued product improvement, Warmington Ind LTD reserves the right to change product specifications without prior notification.

EVOQUE ACC HEAT CELL ASSEMBLED

Note: If plastering the heat cell structure, it is recommended to use a fibreglass mesh with a latex plaster to minimise the chance of the plaster cracking (see your plasterer for correct materials and applications).

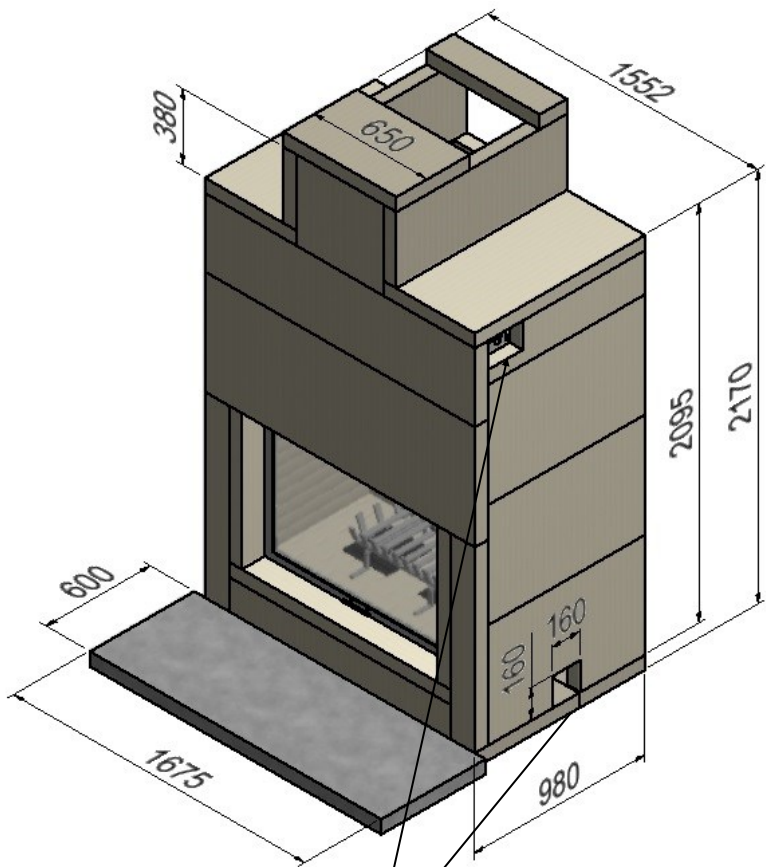
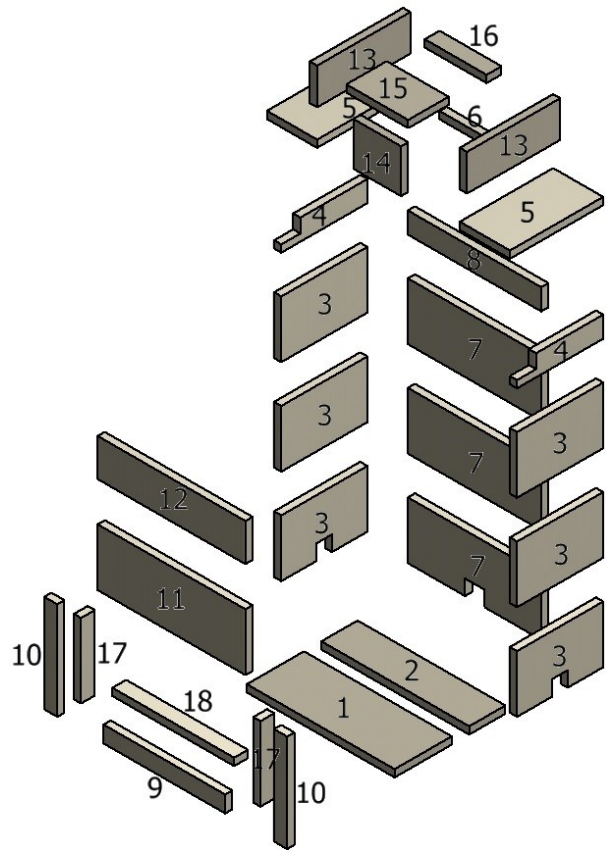

On both left and right side

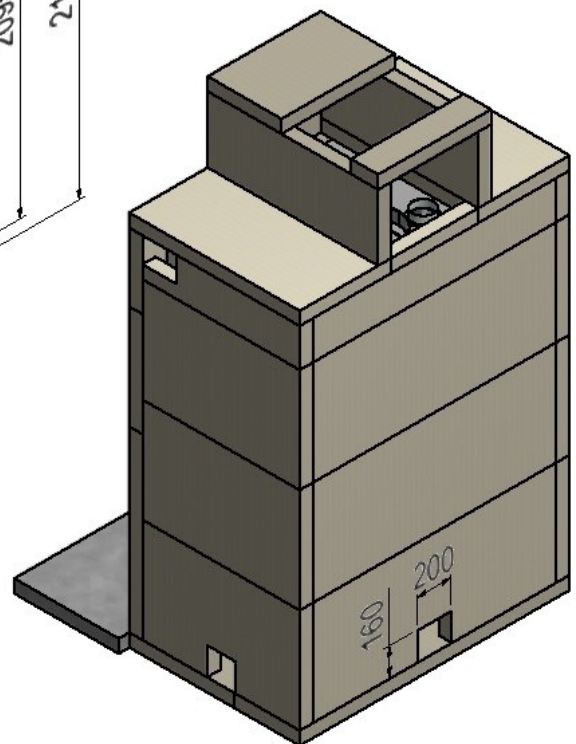

Due to continued product improvement, Warmington Ind LTD reserves the right to change product specifications without prior notification.

ACC HEAT CELL CROSS SECTION

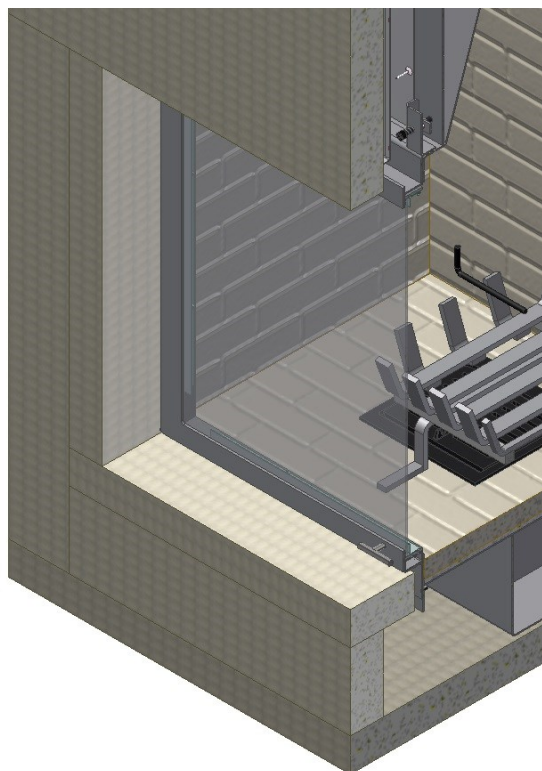
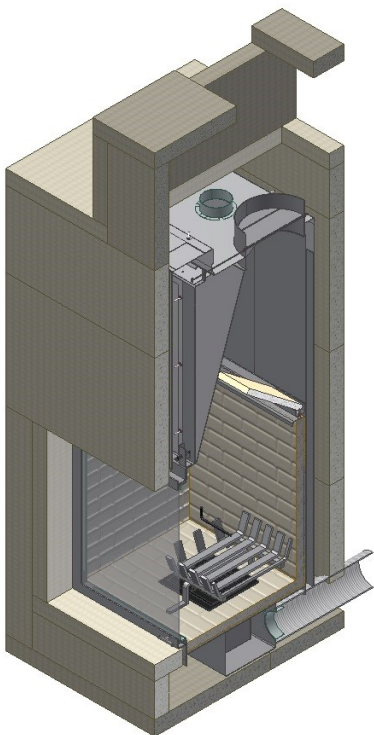
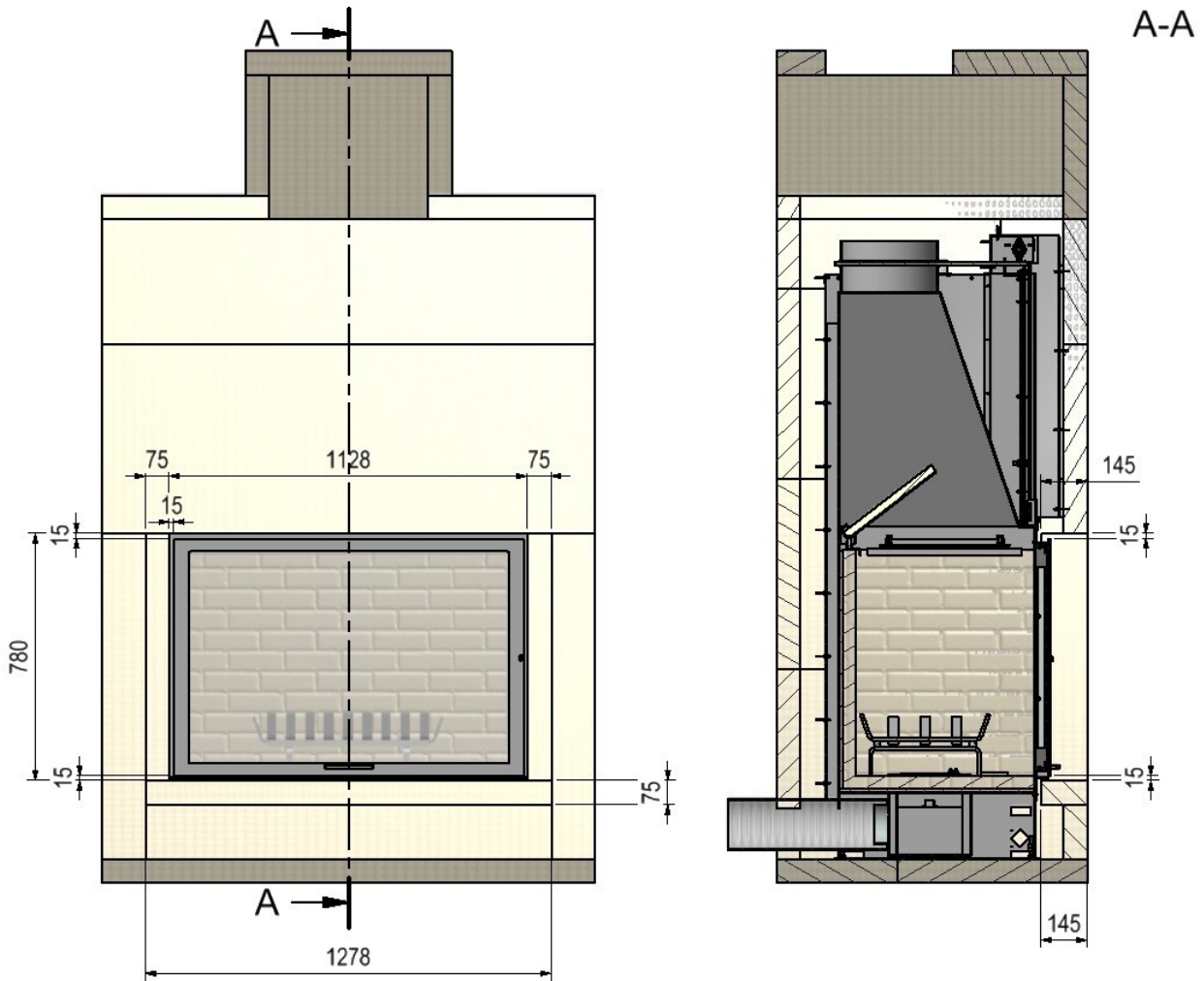

Due to continued product improvement, Warmington Ind LTD reserves the right to change product specifications without prior notification.

Presetting and changing the setting of the damper control

This control allows you to preset opening of the damper trap, which controls evacuation of smoke, when the door is lowered.

The presetting control is located in the centre of the fireplace, above the door.

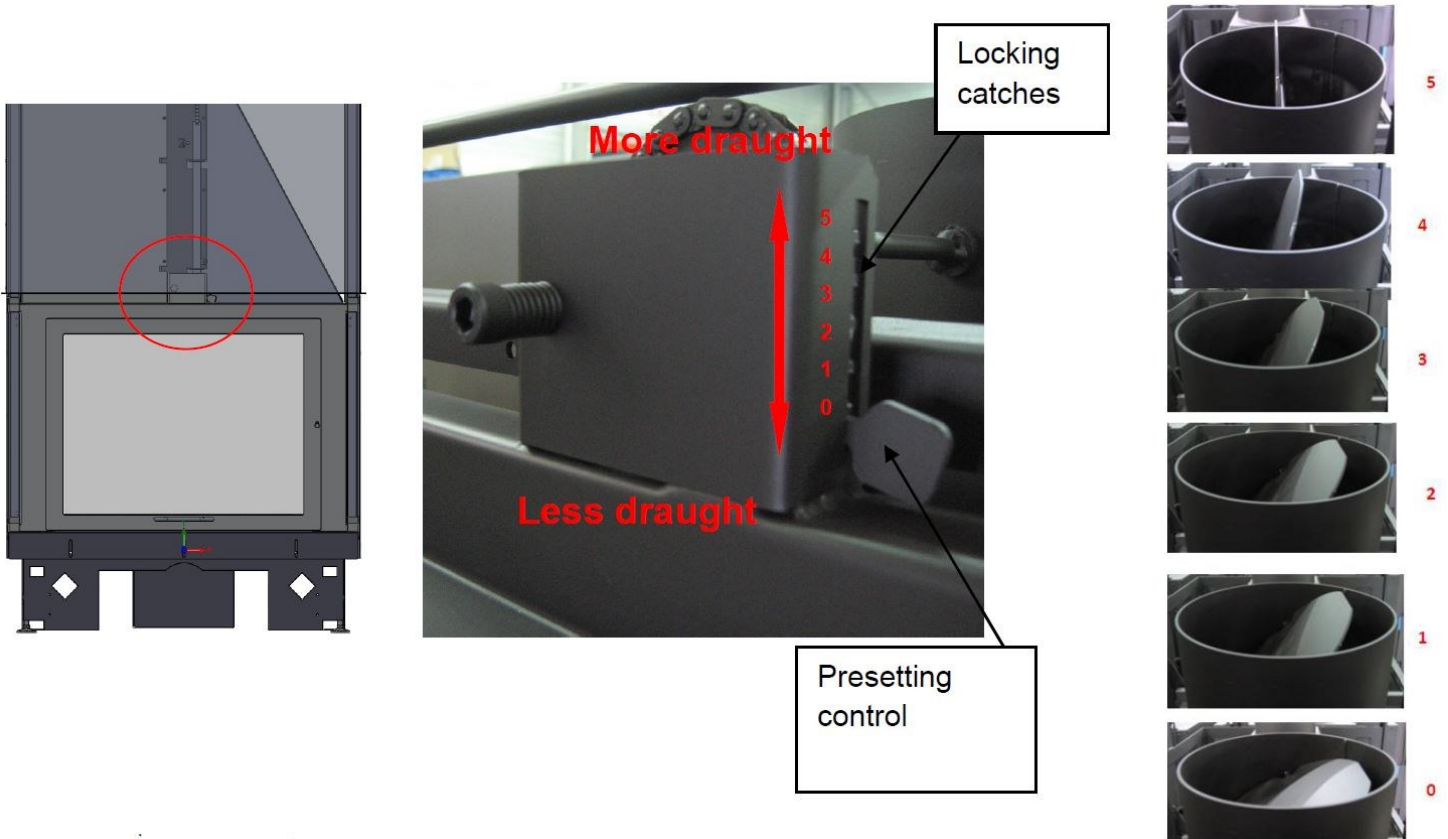

1. Press the presetting control in order to disengage it from its catches.
2. Keeping it pressed, make it slide up or down in order to obtain the desired setting:
 - Control at the top = trap more open → increased draught.
 - Control at the bottom = trap more closed → decreased draught.
3. Once you have obtained the desired position, release the control.
4. When using the appliance for the first few times, it will be necessary to set the damper trap according to the natural draught of your chimney. This is unique to each individual install.

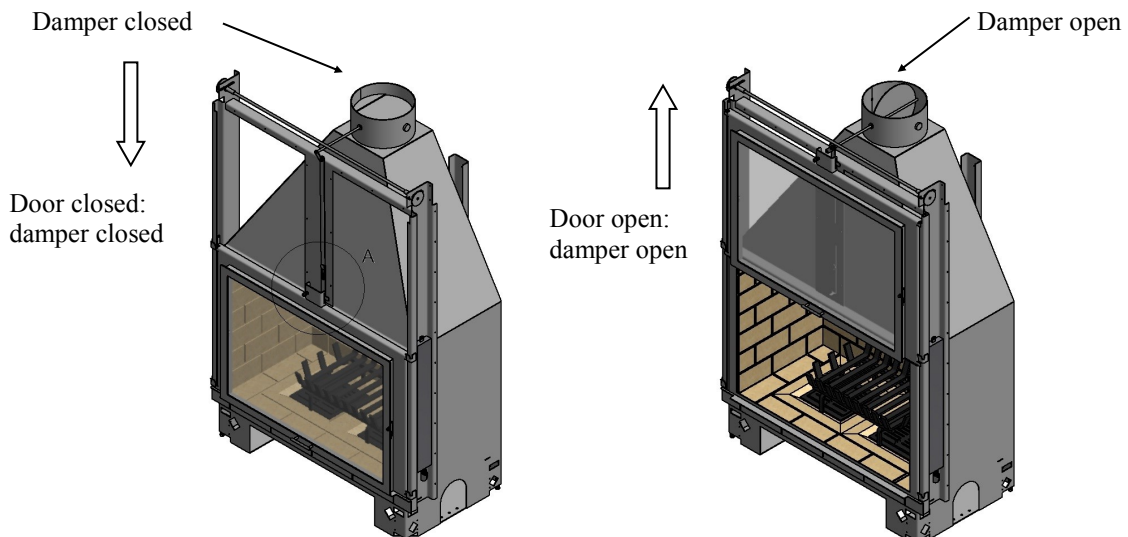

Due to continued product improvement, Warmington Ind LTD reserves the right to change product specifications without prior notification.

Single 3.6m Flue Kit Details

FLUE DETAILS DIMENSIONS

Minimum Flue Height	
Flue Height	3600
Measured From Top of Adaptor	B + F + 3600

Flue Details	No:	Evoque
Cowl	1	300
Top Spider	1	300
Cone	1	300
Flue Diameter	3	300
Liner Diameter	3	400
Spacer	3	300/400

NOTE: FLUE SYSTEMS CASING

Flue system may require to be doubled lined to comply. Refer ASNZS:2918:2001 4.3 flue pipe casing.

NOTE: Ensure that a standard tested Warmington flue system is used on the Warmington fires.

FLUE SYSTEM INSTALLATION GUIDE ONLY

This is a general installation guide only – Contact a “NZHHA Installer” for installation advice or go to www.homeheat.co.nz then select **Members** & follow instructions, to find a certified NZHHA SFAIT installer.

1. Install the first length of flue pipe with the crimped end down, inside the Adaptor collar, ensure that the flue pipe is sealed into the collar with exhaust sealant. Rivet the flue in 3 places around the Adaptor collar. Place a spacer around the flue pipe approximately 150mm above the adaptor collar. Secure in position by tightening the screw and nut.
2. Install the second length of flue pipe with the crimped end down and fit by riveting in at least 3 places around the flue pipe joint. Ensure that the flue is sealed into position with sealant.
3. Install the first section of flue pipe liner with the Crimped end up, over the flue pipe and over the spacer that is fixed to the flue pipe. This spacer will keep the liner concentric about the flue pipe.
4. Position flue spacer at the flue pipe joint for every length of “Flue pipe” and “Liner”. Repeat the Steps from 1-4 to the installed required height of the flue system. The flue system is to comply with ASNZS 2918:2001 4.9.1

- a “the flue pipe shall extend not less than 4.6m above the top of the floor protector.”
- b “ the minimum height of the flue system within 3 m distance from the highest point of the roof shall be 600mm above that point.”
- c “the minimum height of the flue system further than 3 m from the highest point of the roof shall be 1000mm above the roof penetration.”
- d “no part of any building lies in or above a circular area described by a horizontal radius of 3 m about the flue system exit.”

1. **NOTE:** The last length of flue pipe needs to extend past the liner so that when the “top spider” and the “flashing cone” are fitted, that the “flashing cone” and the “flue pipe” are **flush**, or that the “flue pipe” is **5mm lower** than the “flashing cone”.
2. Fit the “top Spider” into position, ensure that the legs of the spider are fitted inside the liner and that the spider is positioned hard down onto the liner and tighten with the screw and nut.
3. Place the “flashing cone” over the “flue pipe” and press hard down onto the “top Spider”. Note that the “flue pipe” and the “flashing cone” are either flush or the “flue pipe” is 5mm lower than the “flashing cone”. Ensure that the “flashing cone” is clear for the venting from the “liner” and the “flue pipe”.
4. Fit the “cowl” to the top of the flue pipe. The “cowl”, “flashing cone”, and the “flue pipe” can be secured to each other with the uses of a stainless steel self tapping screw. This will allow the “cowl” to be removed for cleaning.
5. Flue system may require bird proofing due to the installation and locations, discuss this with your installer for the best advice.
6. If the flue system is installed into a “chimney chase”, allow for air vent as close to the top of the chase as practical, or allow venting through the “chimney chase flashing”. A “venting flashing cone” and a 25mm gap around the liner with a “venting flashing cone-spider” can be used. Refer to figures.

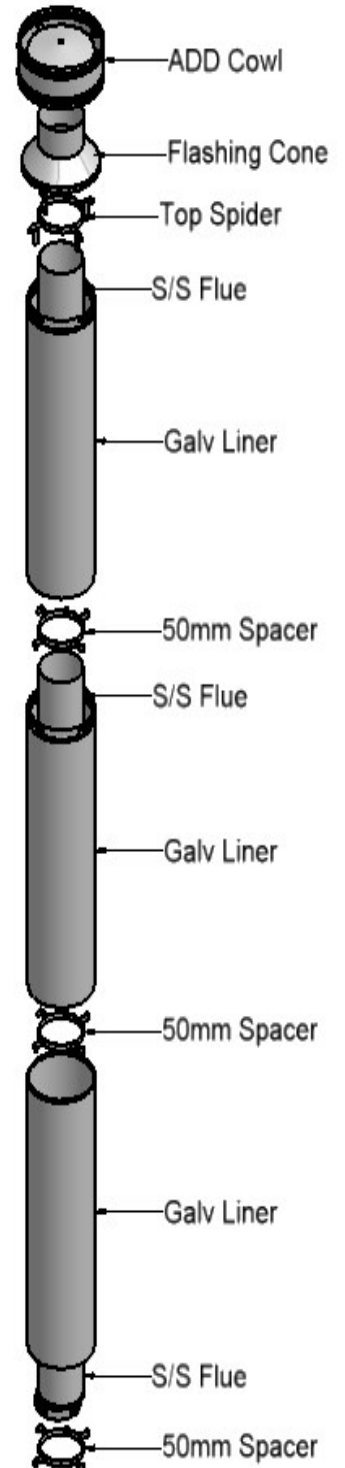

Due to continued product improvement, Warmington Ind LTD reserves the right to change product specifications without prior notification.

FLUE PENETRATION vented through alcove (single lined flue system)

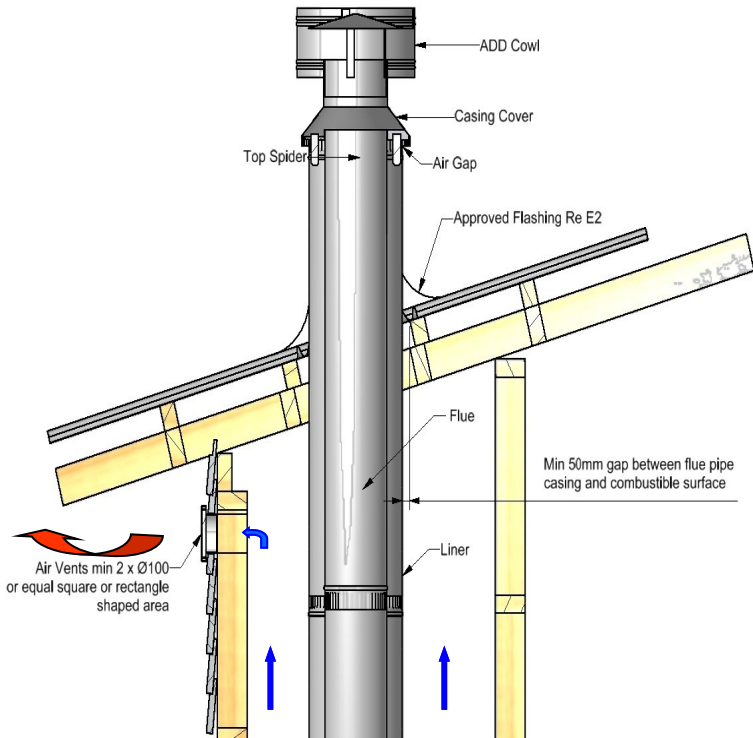

FLUE PENETRATION vented through alcove (double lined flue system)

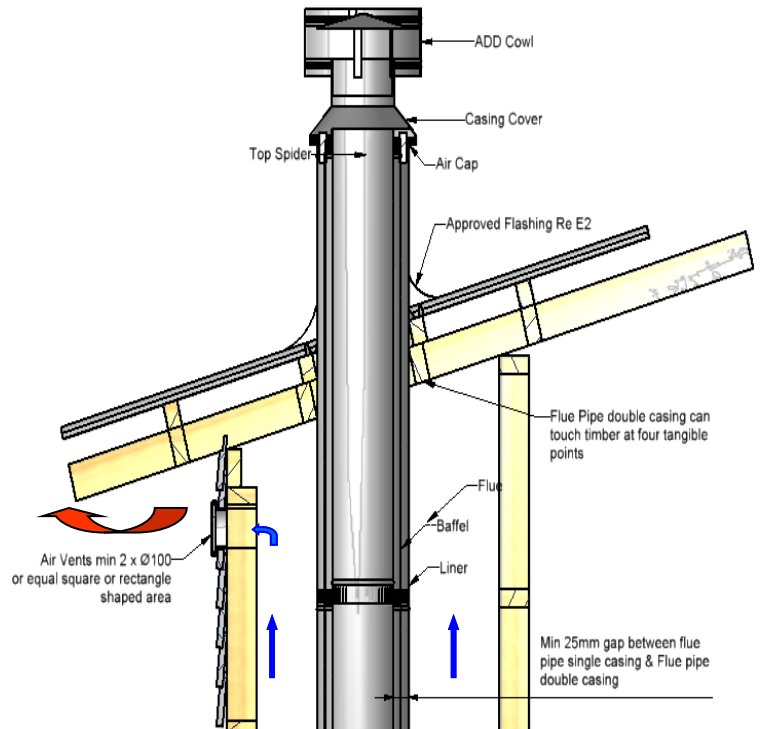

FLUE PENETRATION vented through top flashing

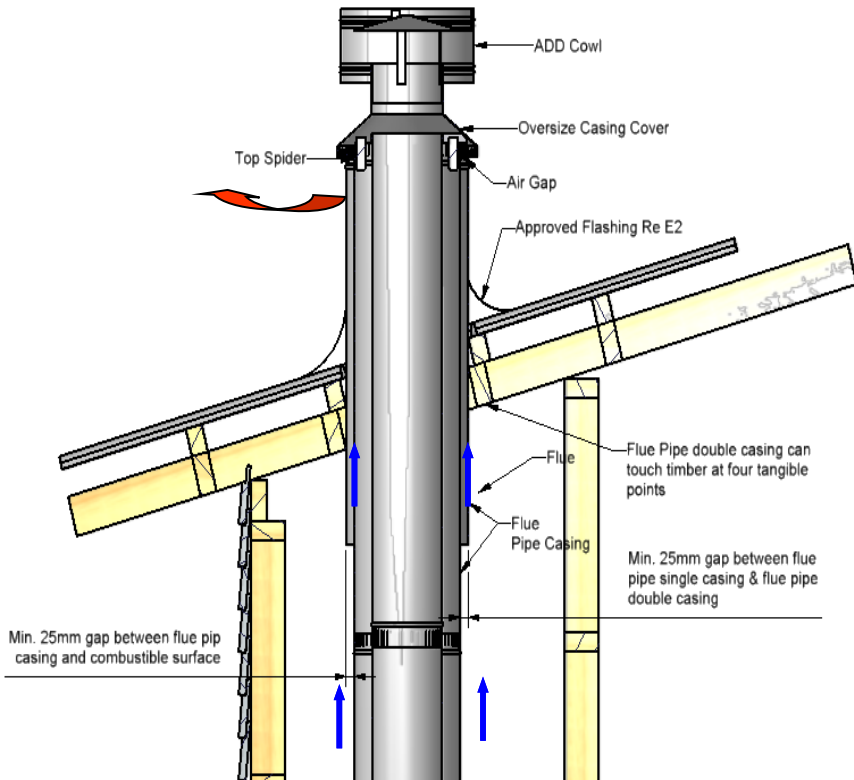

NOTE: FLUE SYSTEMS CASING

Flue system may require to be doubled lined to comply. Refer AS/NZS:2918:2001 4.3 flue pipe casing

Note:

External requirements

Refer to AS/NZS2918:2001 4.9.1

Install flue system to AS/NZS2918:2001

When using a rubber or bitumen flashing (butynol, Dectite, etc.) an additional flue pipe baffle is required.

All external air vents and ceiling penetrations must be bird proofed with permanently fixed screens.

All flashing to comply with E2.

All external air vents and ceiling penetrations are to be vermin and rodent proof.

Test report number	Date of report
04/1039	20 th July 2004
04/1040	20 th July 2004
04/1041	20 th July 2004

Due to continued product improvement, Warmington Ind LTD reserves the right to change product specifications without prior notification.

CHIMNEY CHASE FLASHING DETAILS

SETTING ADD COWL AND FLASHING CONE HEIGHT

General Chimney Chase Flashing Lay Out

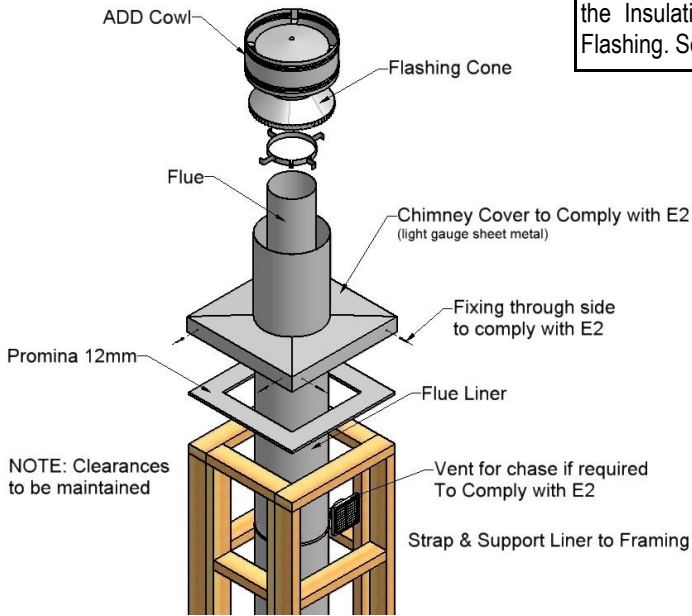

Note:
Flashing spigot height is determined by the Insulation that is fitted under the Flashing. See details at bottom of page.

STEP 1

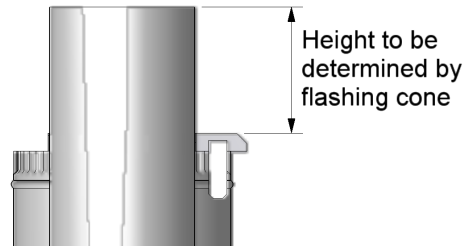

STEP 2

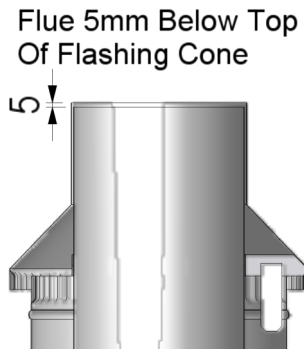

STEP 3

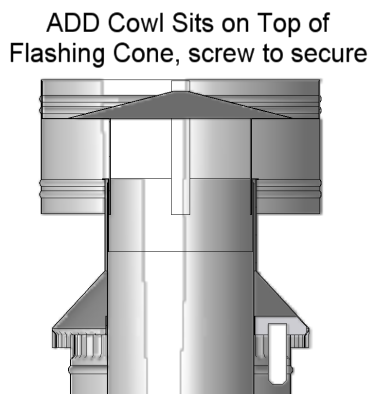

“CHIMNEY CHASE FLASHING” AND “AIR VENTILATION” OPTIONS:

VENTING THROUGH CHIMNEY CHASE

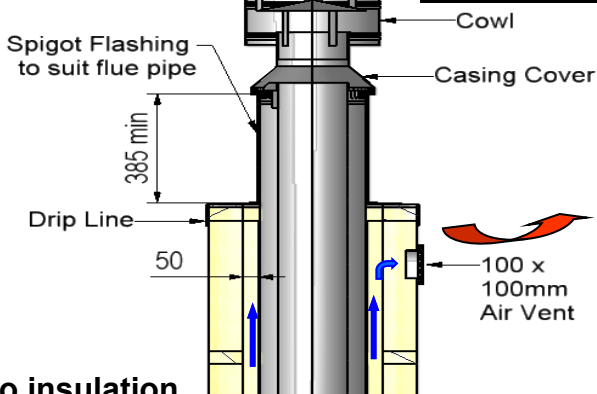

“No insulation under flashing”

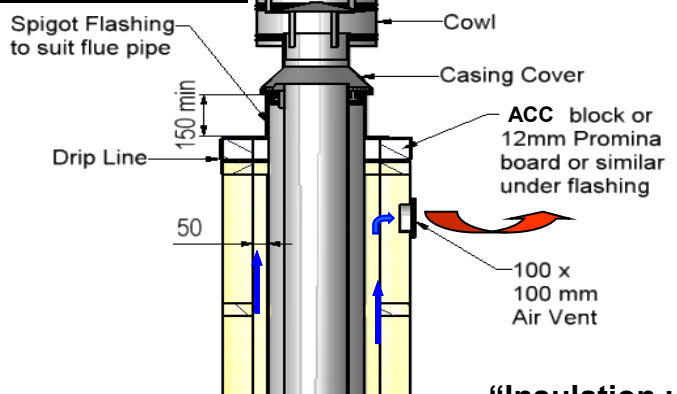

“Insulation under flashing”

VENTING THROUGH FLASHING

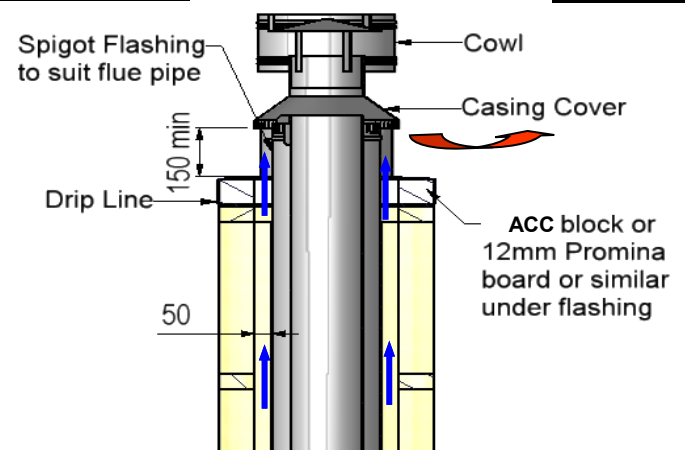
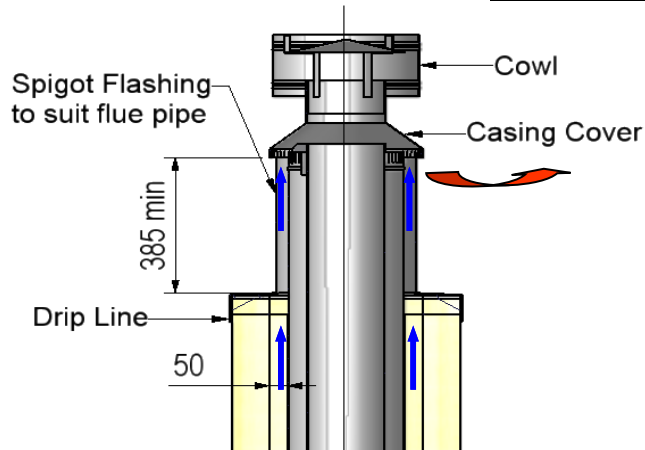

Due to continued product improvement, Warmington Ind LTD reserves the right to change product specifications without prior notification.

FLUE HEIGHT MINIMUM DETAILS

Note: FLUE SYSTEMS CASING
 Flue system may require to be doubled lined to comply.
 Refer ASNZS:2918:2001 4.3 flue pipe casing.

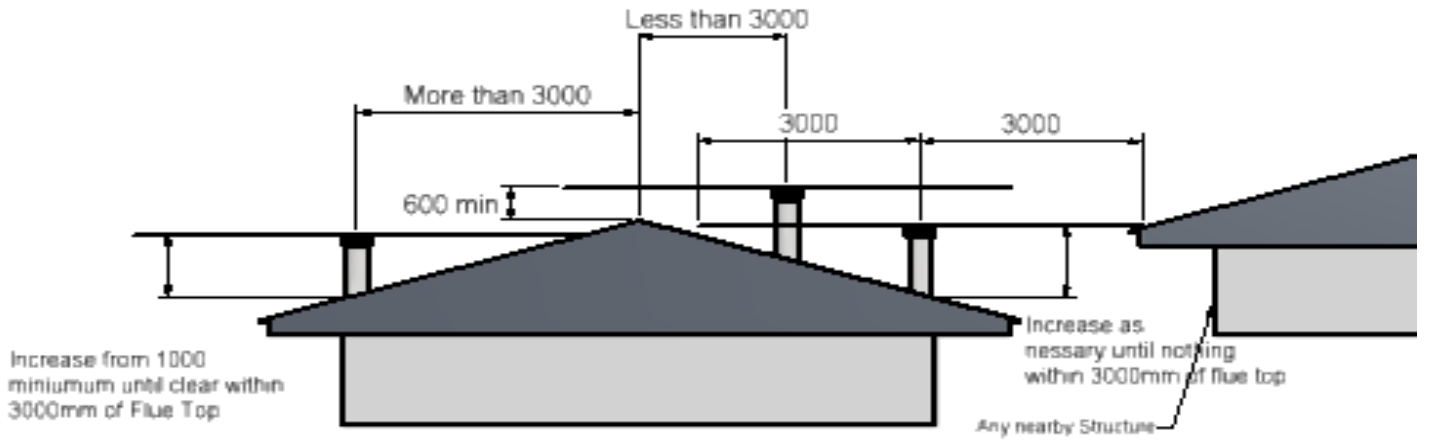

The flue exits are to comply to ASNZS 2918: 2001

3D view

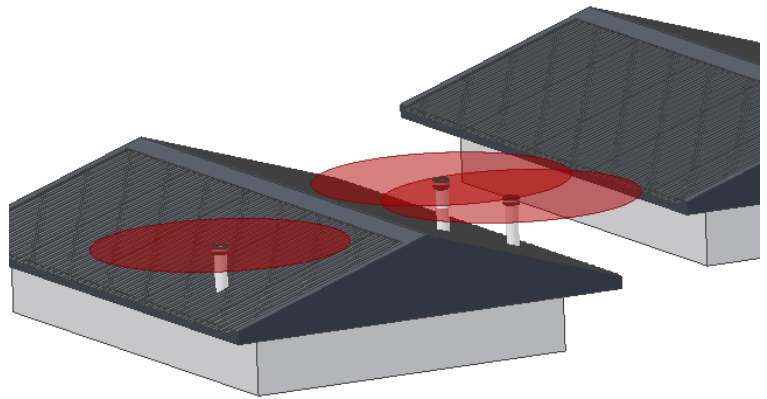

FRAME OUT AND TRIM OUT DETAILS FOR CHIMNEY CHASE

Option X – Singled lined flue system

Option Y – Double lined flue system

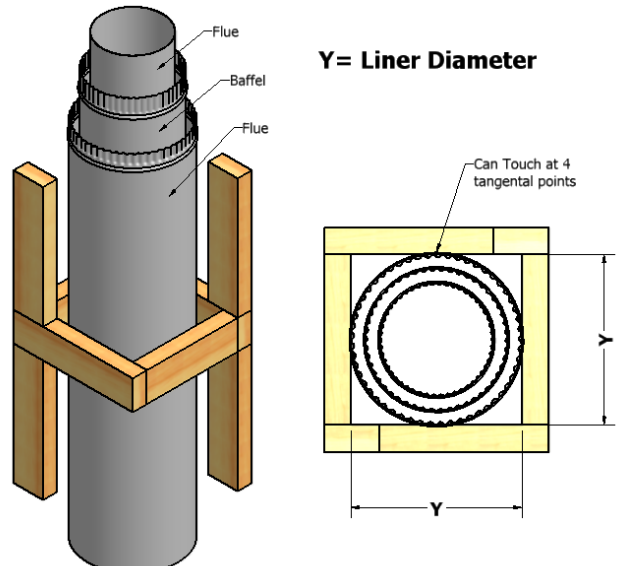
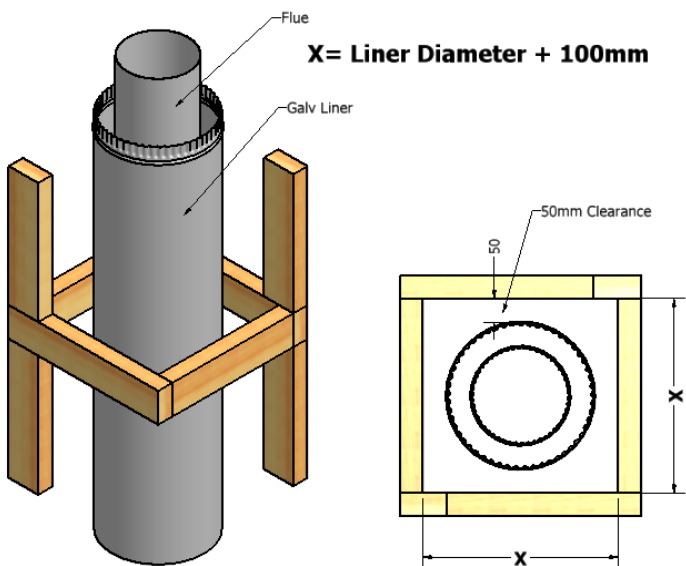

Due to continued product improvement, Warmington Ind LTD reserves the right to change product specifications without prior notification.

GENERAL NOTES: ASNZS 2918: 2001**NOTES:**

- Correct installation must be maintained to comply with Warmington warranty.
- The appliance and flue system must be installed in accordance with ASNZS2918:2001 and the appropriate building codes.
- The flue system and fireplace is to be swept annually or more frequently if required.

WARNINGS:

- **WARNING: ANY MODIFICATION OF THE APPLIANCE THAT HAS NOT BEEN APPROVED IN WRITING BY THE TESTING AUTHORITY IS CONSIDERED AS BREACHING AS/NZS 4013.**
- **WARNING: DO NOT USE FLAMMABLE LIQUIDS OR AEROSOLS TO START OR REKINDLE THE FIRE.**
- **WARNING: DO NOT USE FLAMMABLE LIQUIDS OR AEROSOLS IN THE VICINITY OF THIS APPLIANCE WHEN IT IS OPERATING.**
- **WARNING: DO NOT STORE FUEL WITHIN HEATER INSTALLATION CLEARANCES.**
- **CAUTION: THIS APPLIANCE SHOULD BE MAINTAINED AND OPERATED AT ALL TIMES IN ACCORDANCE WITH THESE INSTRUCTIONS**
- **CAUTION: THE USE OF SOME TYPES OF PRESERVATIVE-TREATED WOOD AS A FUEL CAN BE HAZARDOUS.**

**NOTE: For operation instruction download from the website
www.warmington.co.nz**



**Industries 1994 LTD
PO Box 58652, Botany 2163, Auckland www.warmington.co.nz**

Due to continued product improvement, Warmington Ind LTD reserves the right to change product specifications without prior notification.