

# Retro Fit SI 1250 - 1500 Open Fire

## Installation Instructions into existing Brick / precast Chimney

**\*Option 1: Use Existing Chimney**

**\*Option 2: Use Adaptor & Fluekit**

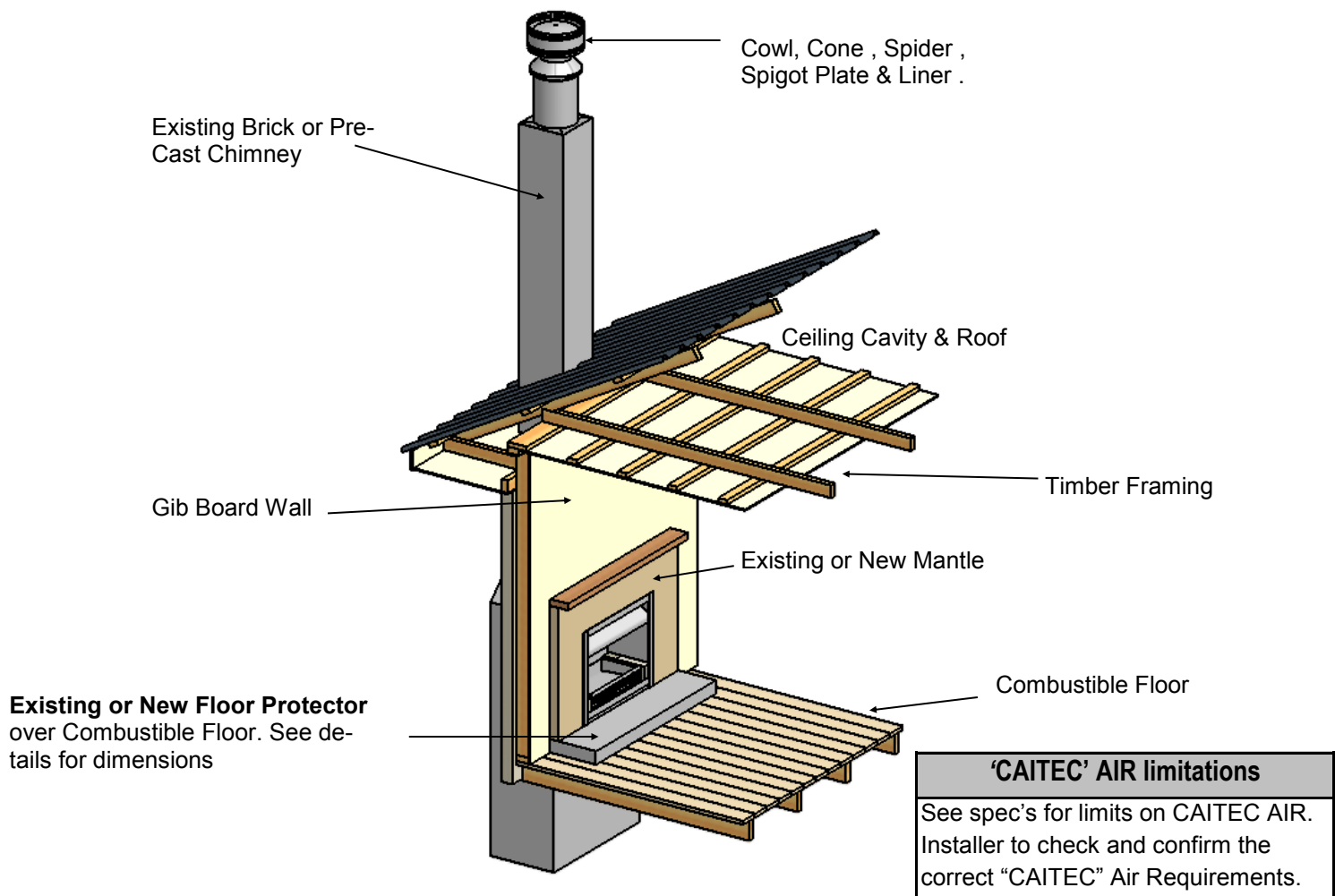

**Visit [www.warmington.co.nz](http://www.warmington.co.nz) for Spec's, DWG's and PDF uploads of Fires**

**Fire, flue system and instructions to comply with ASNZS 2918:2001 & Building Code C/AS1 7.5 Open Fires**

Keep these Instructions for further reference.....Ensure that you have the correct and current Installation details for the Warmington Fire

**Installation**

The Warmington unit is to be installed by a Certified Warmington Installer or an Approved NZHHA SFAIT Installation Technician .  
See [www.homeheat.co.nz/members](http://www.homeheat.co.nz/members) for a Certified NZHHA SFAIT Installer in your area .

**IMPORTANT**

Read all the Instructions carefully before commencing the Installation. Failure to follow these instructions may result in a Fire Hazard and void the warranty

## POINTS TO CONSIDER PRIOR TO INSTALLATION

Location of the Fire. Open fires are better located at one end of a room or area, as they project the heat away from their opening.

### The Topography of the land .

The slope and position of the land in relation to the home has a bearing on how the wind will interact with the fire and flue system. Care needs to be taken to ensure that the flue termination is in the correct position to maximise performance.

### The Prevailing Wind.

Care needs to be taken to ensure that the flue termination is in the correct position as wind and gusts that hits the flue and cowl system may overcome the cowl and draft back down the flue into the home. This can be a combination of down draft and high pressure.

### Hearth and Plinth:

The Height of the Hearth off the Floor. The Finishing that is to be used on the Hearth is to be allowed for at the design stage.

Note : Ensure Air Intake at Base of Firebox is not blocked or restricted .

### Positioning of the Flue System:

There is a maximum distance that an offset flue can be Installed . Reference to AS/NZS 2918:2001.

### Flue And Fire Clearance:

To be maintained to the Manufactures Instructions &/or Comply with appropriate Standards & Building Codes .

### Pressure Differential, Venting & External Air into the Building :

All fires need air to burn and draw correctly, Kitchen Fans, Air Conditioning units, High Wind Zones, Naturally forming Draft spaces, can all have an effect on the pressure difference from inside the building to the outside. A lower pressure in the building may induce a draft down the flue system and back into the building causing the fire to smoke or spill into the building. **Care needs to be taken at the design and installation stage to adequately vent the building, or some mechanical system to ensure that there is always a neutral or positive pressure at the fireplace and a negative pressure at the flue outlet.** This will ensure that the draft in the flue system is always to the outside.

“CAITEC AIR” the limits and requirements. See details in these Spec's

### Wind Noise:

You may encounter wind noise in some installations. It is recommended to use an enclosed chase with a chimney pot to help reduce noise. There will always be some noise from the flue systems of all fireplaces.

## Using the Existing Chimney as the Flue System.

Ensure that the Existing Chimney Comply to the Appropriate Standards & Building Codes.

If the Chimney is not sound or needs repair then a Flue system may be required through the existing masonry Chimney. See Spec's in later pages.

The integrity of the Chimney needs to be confirmed by the Installer at the time of Installation.

## INSTALLATION ORDER OF OPERATIONS

### Prior to Construction and Installation Important Notes:

Install to AS/NZS 2918:2001 by Certified NZHHA SFAIT Installer . See [www.homeheat.co.nz](http://www.homeheat.co.nz) .

The Fire must be Installed to Manufacture's Specifications.

All New Installations require an Application for Local Council Permit/Consent No (Repairs on Fire NOT Included.)

For Special Requirements concerning materials (Timber Mantles and Surrounds) within close proximity of Warmington products, please contact your local Warmington Technical Consultant .

Install Procedure by Certified “Warmington Installer” only , or see [www.homeheat.co.nz](http://www.homeheat.co.nz) go to “members & follow Instructions to Get a Certified NZHHA SFAIT Installer .

### Stage 1: Removing Existing Fire (Brick Fire , Register Fire or Inbuilt .)

**Important Note :** Before Fire Removal , Check Outside & Inside of Chimney Chase for Structural Cracks etc . These will need to be Repaired .

Remove Old Flue System if Required & then remove Existing Fire from Chimney Chase.

Sweep Chimney & Clean entire chase out thoroughly . If a Ash Pit Exists at base of Fire , this will need to be sealed or covered over .

A new Plinth & Hearth may need to be Installed if necessary .

The Existing Mantle Opening may need to be Cut Out or Closed Down to accommodate the Warmington Firebox .

### Stage 2: Installing Warmington Retro Firebox .

In most cases there will be a Gap around Firebox once in place . This needs to be filled in with a Non Combustible Material & with a 45 degree Chamfer at the Top for Ash to fall back into the Firebox , prior to Installing Fire . See following pages .

Install Firebox into Mantle Opening ensuring Firebox Flange ends up hard against Mantle Opening Face to create a good seal .

Secure Fire in place .

### Stage 3: Installing Chimney Top Flashing System .

Remove any Existing Cowl or Top to leave a Flat Clean Surface .

Cut Spigot Plate Flashing to suit size of Chimney Top & secure level & in place with 6mm dynabolts or equivalent use Silicon to seal Spigot Plate . Note : The diameter of the Spigot Pipe should be equivalent to the Flue Size required for Fire type .

Mortar or Concrete over Spigot Plate .

Install Liner (cut to length) , Spider , Cone & Cowl . Also Bird Protection by Installer if required .

Ensure that the Warmington and flue system is swept annually or more frequently if required.

### To Sweep Flue System and Firebox :

Cover Front of Fire with sheets.

Remove Cowl from Top of Chimney.

Sweep from the Top, Down the Flue.

Remove all Soot and Ash from Ashpan .

Ensure Cowl and Bird Protection is clean and replaced .

Visually Inspect Fireplace and Flue / Flashing System.

**SELECTION OF THE SIZE OF FIRE TO FIT THE EXISTING CHIMNEY**

The size of the fire and the size opening of the flue needs to be balanced for the fire to operate correctly.

The size of the Warmington firebox that is to be fitted to an existing masonry fire place, is generally set by the opening of the masonry flue system X and Y. (see box below).

Remedial work may need to be carried out to physically fit the firebox into the masonry opening, however this may limit the size of the fire that can be fitted.

Firebox		SI 1250	SI 1500
Flue	K	350	350
Flue Liner	L	450	450

Firebox can also be custom built to suit.  
(modification cost will be incurred)  
**See this detail later in the spec's**

**FIREBOX SELECTION**

Remedial work may be necessary to fit the firebox into the masonry cavity, BUT the flue diameter 'K' will determine the size of the firebox.

The selected Firebox flue - (diameter "K") MUST be able to pass through the masonry chimney whether the flue pipe is being used, or the existing chimney is being used.

Always consult your Technical Representative for advice.

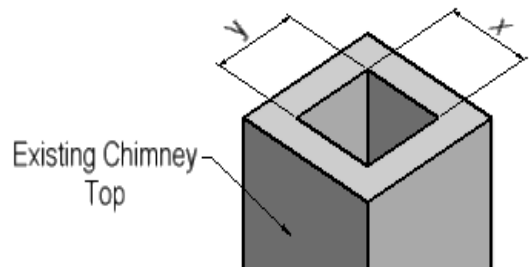

**FLUE HEIGHT MINIMUM DETAILS**

The Height of the masonry flue may need to be increased to obtain correct operation.

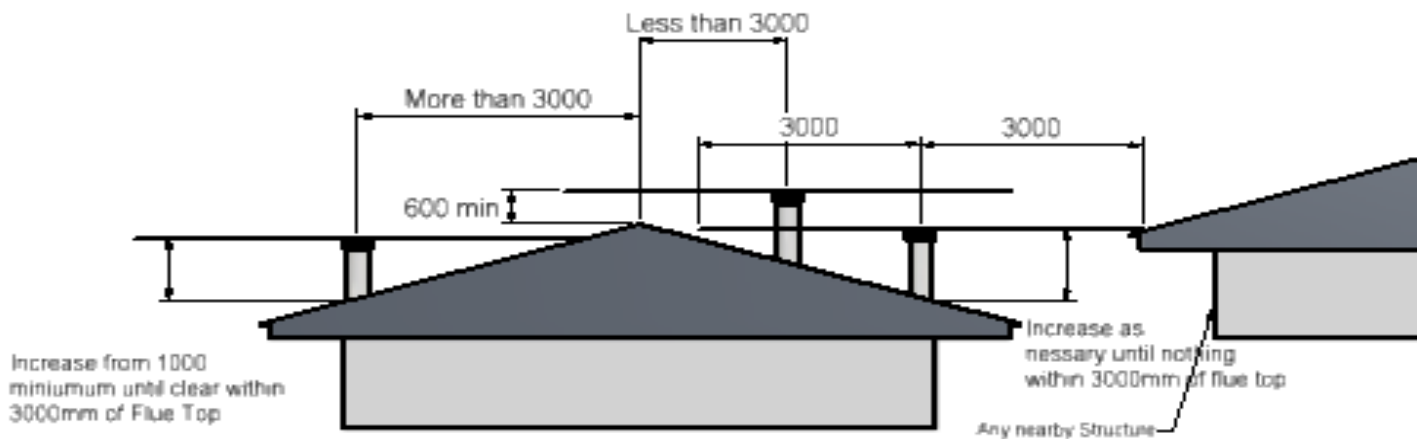

The Flue penetration is to comply to AS/NZS 2918 : 2001

**3D View**

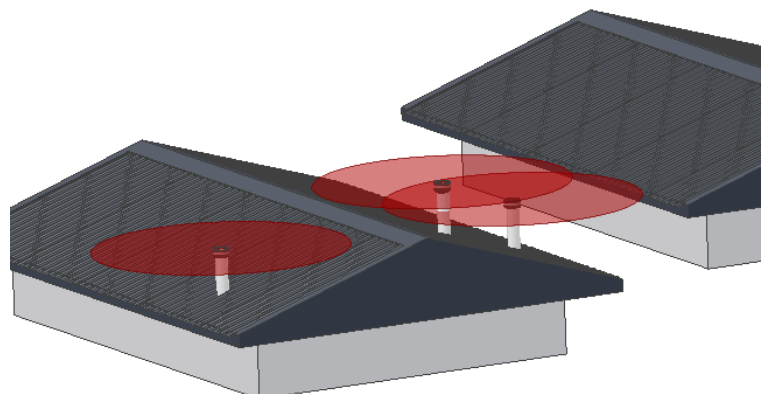

**“CAITEC” and the BLANKING PLATE.**

For fitment into existing chimneys the “CAITEC” is blanked off. This is due to the “CAITEC” and the flue being in the same flue system.

Additional “CAITEC” Air can be provided by venting the home as close to the fireplace as possible. See concept of external air supply.

If an adaptor and stainless steel flue system is fitted to the fire within the existing masonry chimney, the “CAITEC” Blanking Plate can be removed. The existing masonry fire place can be vented to an external air supply at the lowest level and the full advantages of “CAITEC” air will be provided.

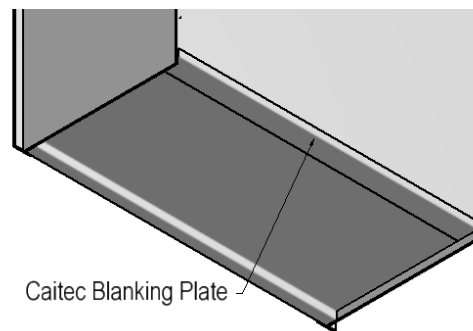

**‘Caitec’ Weir Vent System (concept only)**

**‘CAITEC’ TECHONOLGY - ROOM AIR REPLACEMENT**

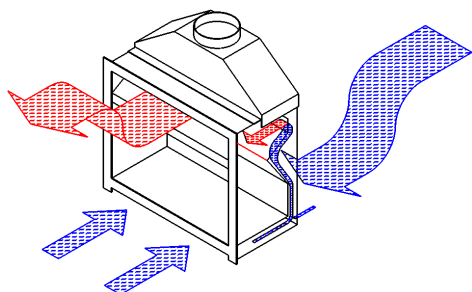

“Caitec” draws air from an External Air Source to ensure that combustion air that the open Fire uses is replaced, maintaining the home at a constant pressure equilibrium, reducing the risk of back drafting.

Ensure that the home is vented to outside Fresh Air. 2 x 100mm diameter vent are required (or equivalent to that).

**Builder to supply external air to the ‘Warmington Fire’ (not supplied).**

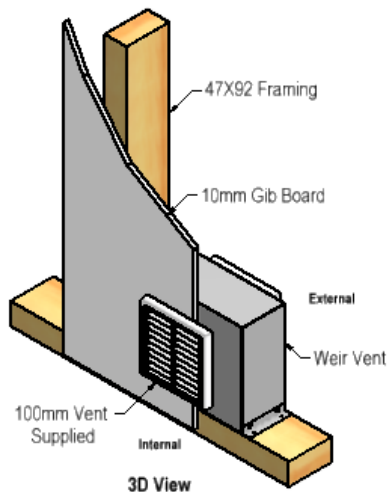

3D View

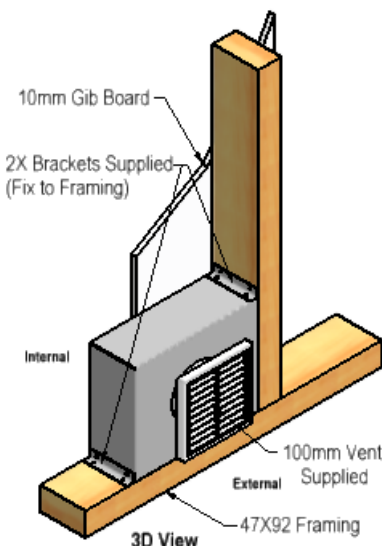

3D View

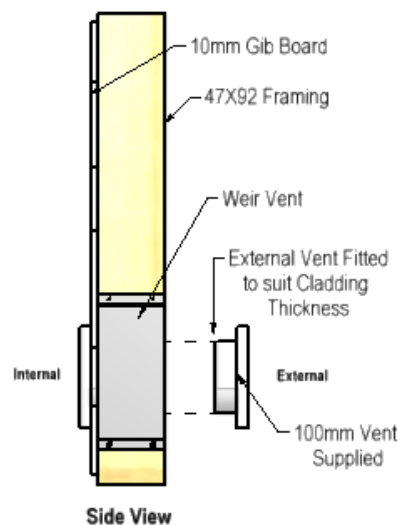

Side View

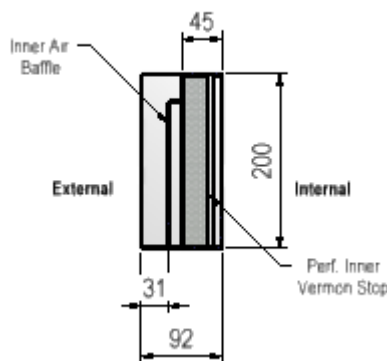

Side Section View

**Important Note:**  
For optimum performance place ‘Caitec weir vent system as close to Fireplace as possible.

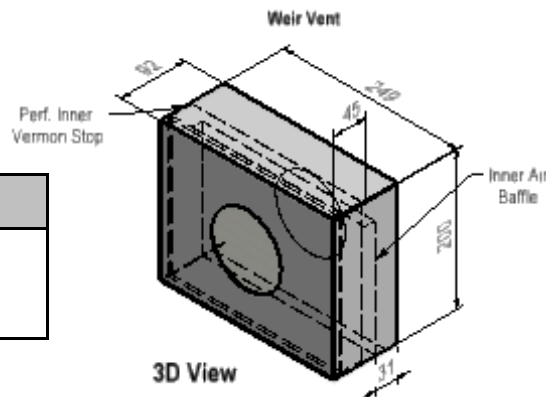

3D View

**WARMINGTON FIREBOX DIMENSION**

Firebox		SI 1250	SI 1500
Firebox Width	A	1250	1500
Firebox Height	B	1000	1000
Firebox Depth	C	600	600
Flange Width	D	1300	1550
Flange Height	E	1025	1025
Alcove Width	F	1270	1520
Alcove Depth	G	610	610
Hearth Projection	H	750	850
Hearth Width	I	1800	1900
Spigot Plate Flue Dia		350	350
<b>Heat Output</b>	<b>kW</b>		
Peak*		30	35
Range*		14	14

\*Estimated unless stated otherwise.

Firebox can also be custom built to suit (modification cost will be incurred)	Sizes mm
<b>WIDTH A</b>	mm
<b>HEIGHT B</b>	mm
<b>DEPTH C</b>	mm

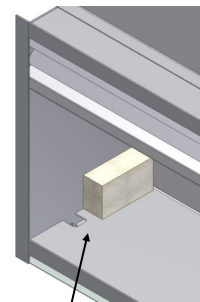
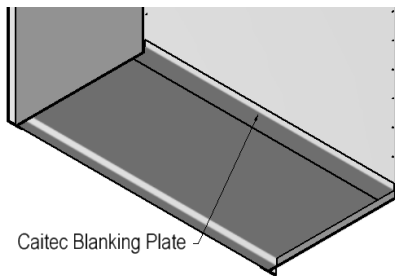

Seismic Restraint Located under bricks

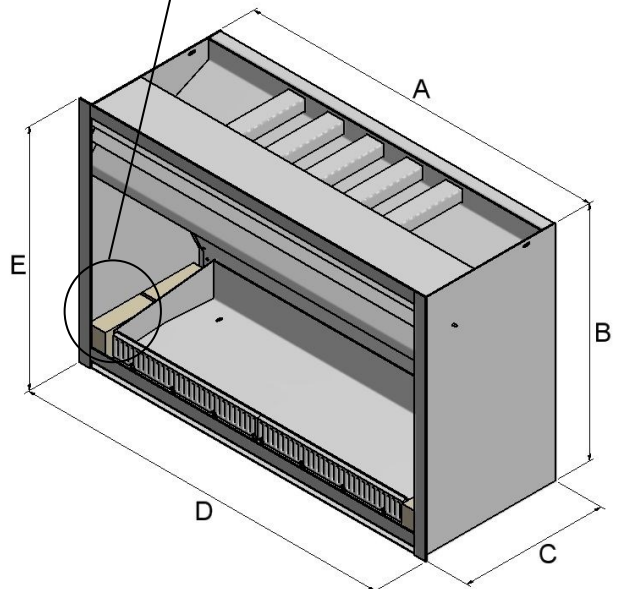

**Note: Timber Framing**  
 All combustible materials to be 50mm away from chimney structure in accordance with appropriate Building Codes.

**Seismic Restraints**  
 Secure Firebox in place with 2X seismic restraints (not supplied). Can be drilled through the base of fire, use 2X dyna bolts to secure.

Minimum Flue Height	
Top of Hearth to Top of Cowl	4600

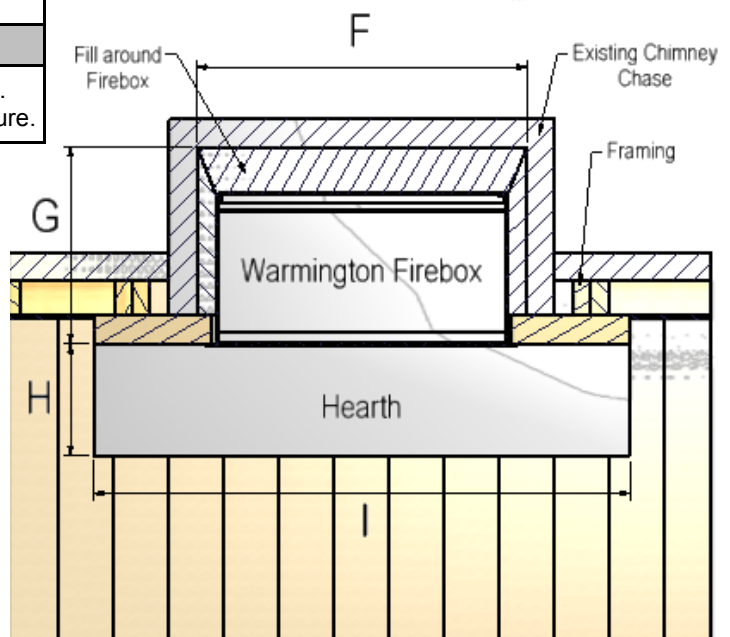

Check List	Tick Box
Firebox	<input type="checkbox"/>
Ash pan	<input type="checkbox"/>
Bricks	<input type="checkbox"/>
Louvers	<input type="checkbox"/>
Badge	<input type="checkbox"/>
Damper Handle	<input type="checkbox"/>
Packed By	

## FIREBOX INSTALLATION

This is a general Installation guide only – Contact a “NZHHA Installer” for Installation Advice.  
 See : [www.homeheat.co.nz](http://www.homeheat.co.nz) , choose “members” & pick your area & fire type (wood / gas etc) this will provide you with a NZHHA Certified Installer (use the SFAIT Installers only ).

### Using the Existing Chimney as the Flue System

Ensure that the existing chimney complies to the appropriate Standards & Building Codes.  
 If the Chimney is not sound or needs repair then a Flue system may be required through the existing masonry chimney. See spec’s in later pages .  
 The integrity of the chimney needs to be confirmed by the Installer at the time of installation .

1. All the dimensions are millimetres.
2. Ensure that an Insulating Plinth is installed as per the Specifications. **Ensure that the plinth is elevated to allow for finishing on the Hearth (see hearth and plinth details).**
3. Install Rockwool (Fire Resistant Insulation) or 75mm ACC Block into cavity around firebox .
4. Fit the firebox into the cavity, the flange should have a tight seal around opening of existing cavity. Bolt the Firebox to the plinth or through the floor. This may require drilling through Fire Base under the ashpan & bolting in place . (Seismic Restraints).
5. Install the Retro Flue/Cowl system. (see page 7.

## HEARTH & PLINTH CONSTRUCTION DETAILS

### IMPORTANT NOTE:

**Note: Hearth and Plinth Construction**  
 For combustible flooring, an insulating hearth and plinth of 75mm is required.  
 Plinth to be offset above hearth for the hearth finishing ( e.g. tiles / granite / plaster / etc.)

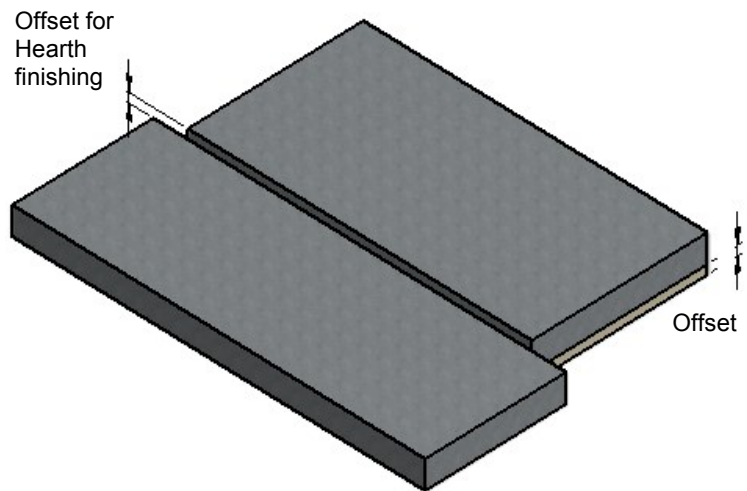

**\*Note: If Solid Plastering the Heat Cell enclosure, it is recommended to use a Fibreglass Mesh with a Latex or Silicon based Plaster to minimise the chance of the plaster cracking (see your Solid Plasterer for correct materials and applications).**

**Visit the Warmington Web Site for “ACC Block (Hebel)” instruction (PDF Download)..**

**OPTION 1: Using existing chimney as flue**

**Existing fireplace opening clearances:**

Firebox		SI 1250	SI 1500
Window Width	J	1270	1520
Window Height	K	1010	1010
Hearth Height	L	75	75

**FIREBOX & CHIMNEY CHASE SECTION VIEW**

**EXISTING FIREPLACE OPENING CLEARANCES**

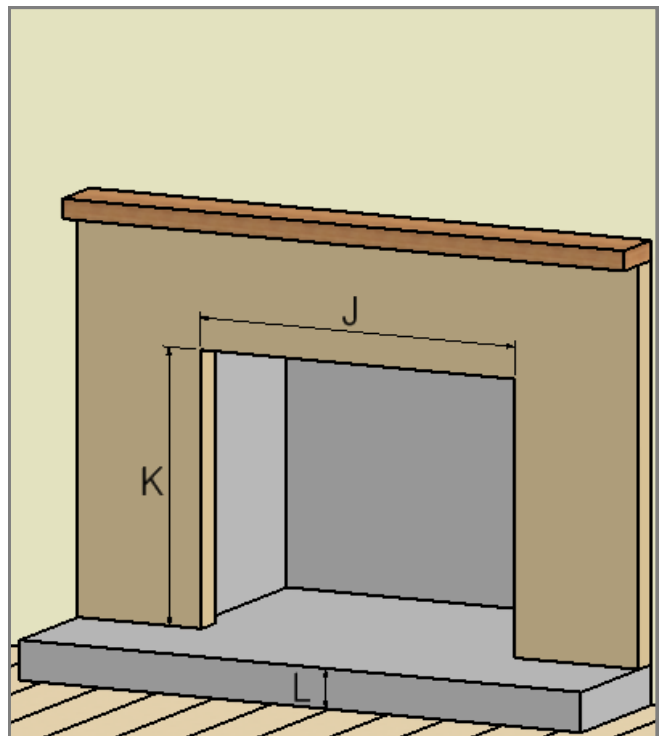
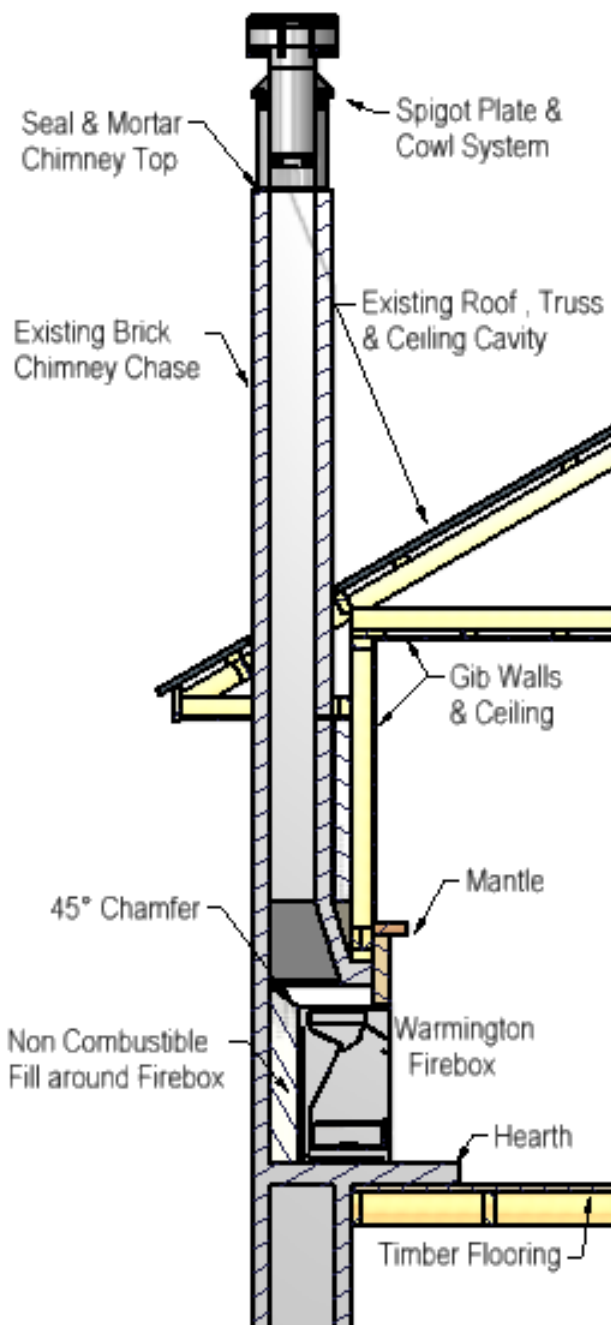

**Note : Timber Framing (To be confirmed by the Installer on site)**  
 All combustible materials to be 50mm away from chimney Structure.

**'CAITEC' AIR (Installer to check)**  
 For fitment into existing chimneys the 'CAITEC' is blanked off. This is due to the 'CAITEC' and the flue being in the same flue system.  
 Additional 'CAITEC' Air can be provided by venting the home as close to the fireplace as possible. See concept of external air supply (not supplied).

**STEP 1: REMOVE EXISTING FIREPLACE**

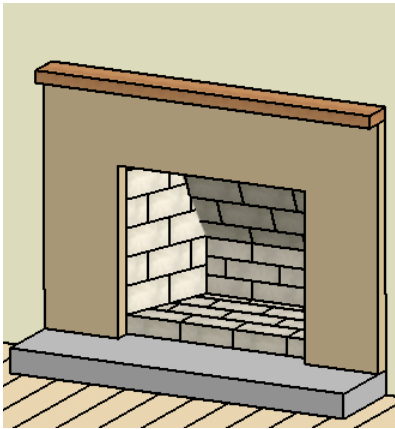

**STEP 1a: Remove Fireplace**  
 Once the main chimney structure has been assessed & complies with the Building code, remove existing fireplace eg. brick or insert Firebox.

**STEP 1b: Clean out Cavity**  
 Once existing brick or insert Fireplace has been removed, sweep out chimney & remove all debris from chimney cavity.

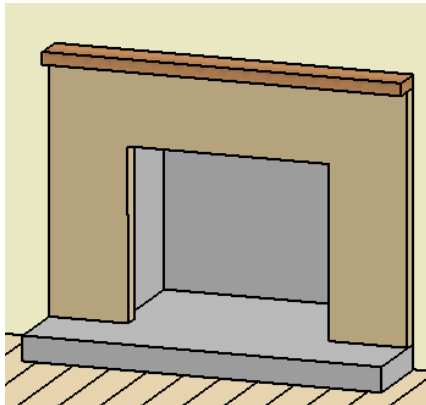

**STEP 3: FILL VOIDS AROUND FIREBOX**

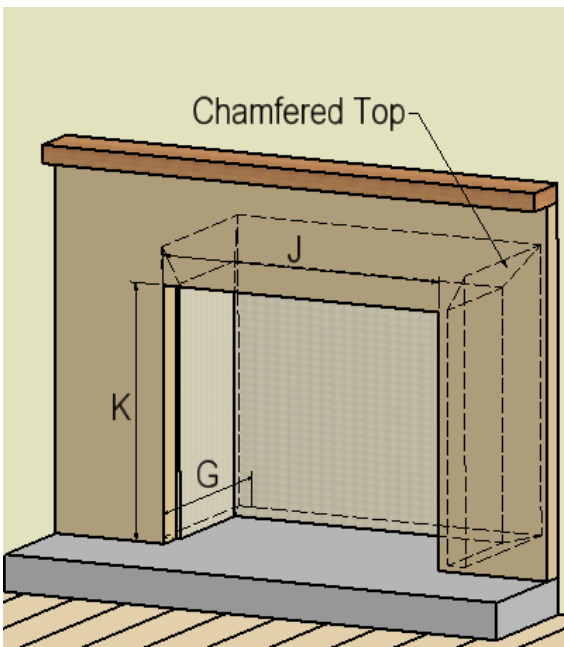

**STEP 3: Fill Voids Around Firebox**  
 Mark out firebox size on plinth & fill void around firebox with non combustible material eg: Rockwool Insulation or Hebel panels is recommended, chamfer top of fill. this encourages ash & debris to fall back into firebox when the chimney is swept.

**STEP 2: MEASURE ALCOVE & HEARTH**

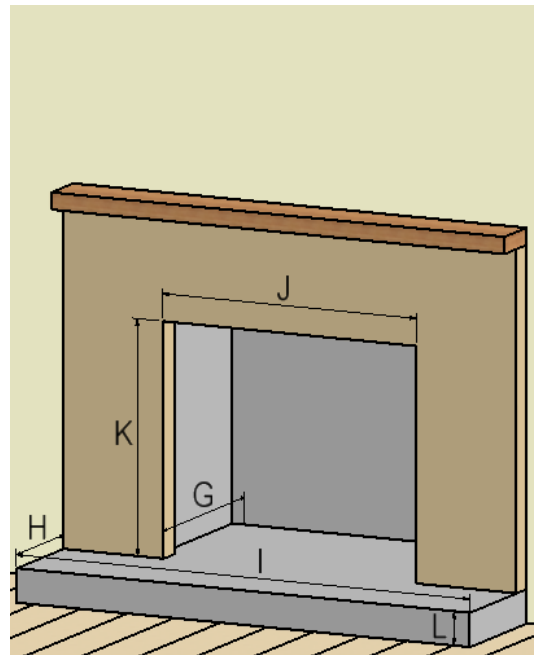

**STEP 2: Check Cavity Size**  
 Check cavity Sizes as above to suit Firebox. In most cases reducing or enlarging these dimensions may be required to suit Firebox.

**STEP 4: INSTALL FIREPLACE & SEAL**

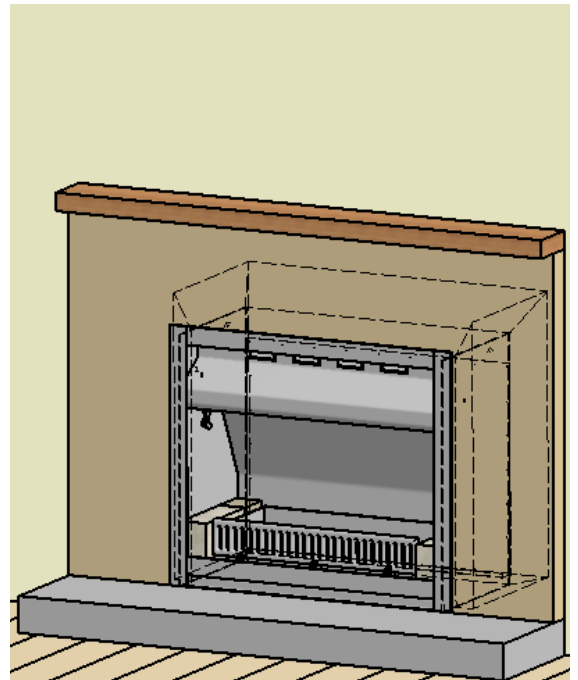

**STEP 4: Install Firebox in Place**  
 Slide firebox in place ensuring a tight seal is created on inside of firebox flange against mantle face heat resistant sealant may need to be used. Secure firebox in place, this can be done by drilling & bolting through base under ash pan. Drill to suit.



**SUGGESTED CHIMNEY CHASE FLASHING DETAILS (using existing chimney as the flue)**

**Using the Existing Chimney as the flue system**

Ensure that the existing Chimney complies with the appropriate Standards & Building Codes.

**Retro Fit Chimney Flashing Detail**

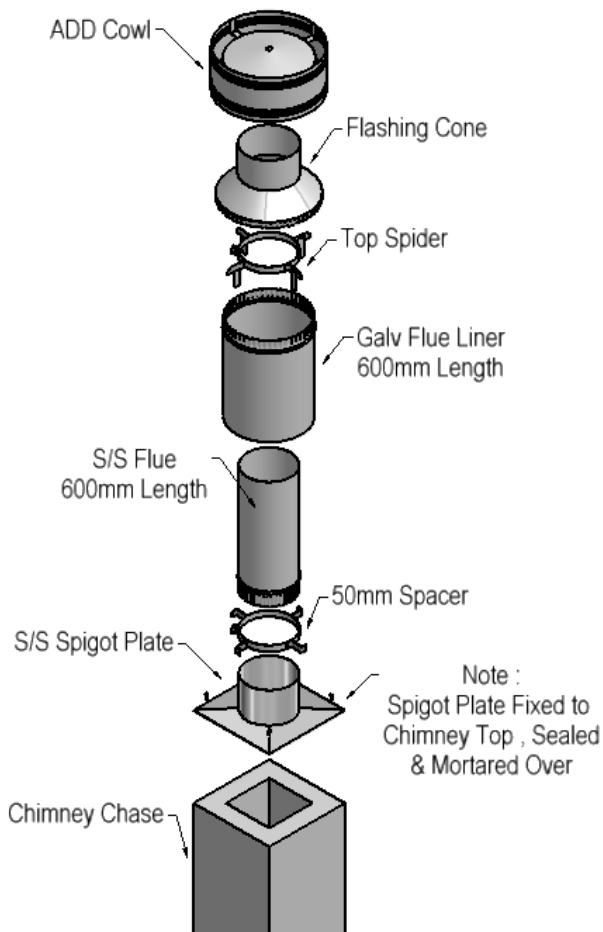

**NOTE:**  
Chimney flashing must be made weatherproof and no water should be able to get down Chimney chase at any time.

**SUGGESTED FLASHING & COWL SYSTEM INSTALLATION**

- Suggested Installation Details:**
1. Remove existing cowl system & clean/remove any debris at top of chimney chase.
  2. Cut the spigot plate 20mm+ smaller than chimney top if necessary, & dyna bolt or fix in place centred on chimney top. Seal around spigot with sealant and mortar plaster over the spigot plate & create runoff for water.
  3. Rivet flue to spigot plate in place & install spacer near bottom of flue.
  4. Cut liner down to suit cowl & cone system. Use steps below.
  5. Bird Protection by Installer if necessary.

**SETTING A.D.D COWL & FLASHING CONE HEIGHT**

**STEP 1**

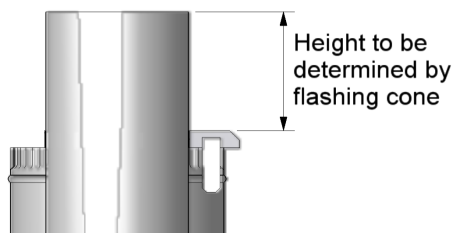

**STEP 2**

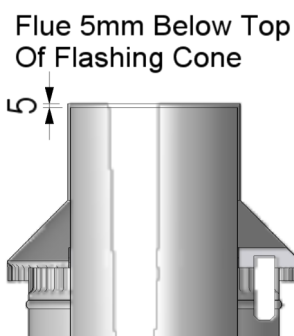

**STEP 3**



**OPTION 2: Using offset adaptor and inset flue kit**

**Suggested Chimney chase flashing details:**

Firebox		SI 1250	SI 1500
Flue	K	350	350
Flue Liner	L	450	450

**FIREBOX , OFFSET ADAPTOR & FLUE SYSTEM SECTION VIEW**

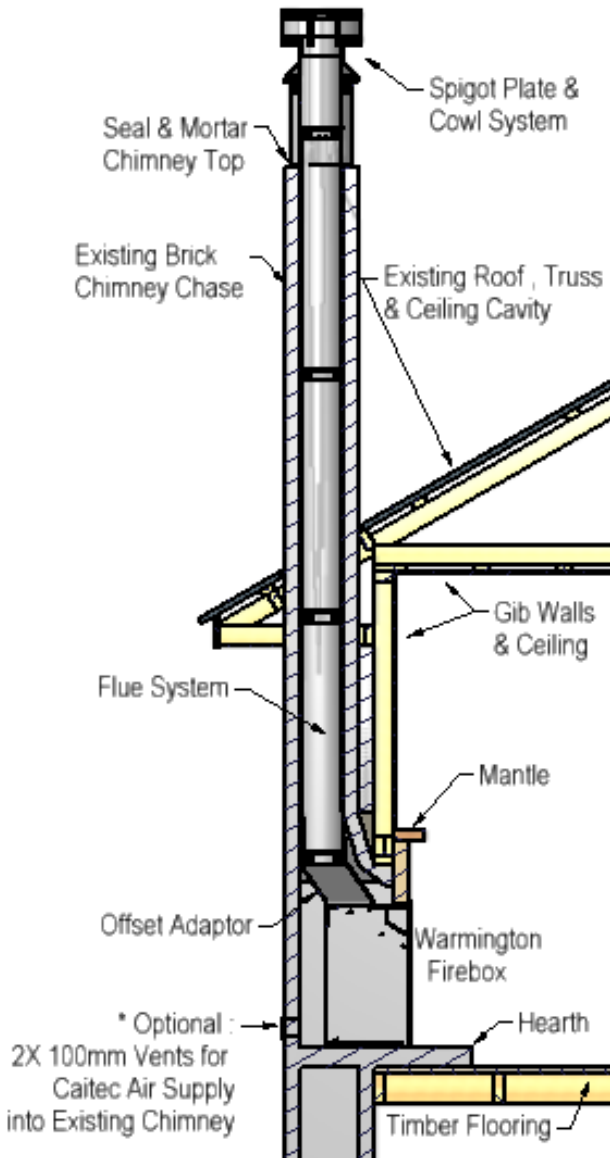

**FLUE SIZE REQUIREMENTS**

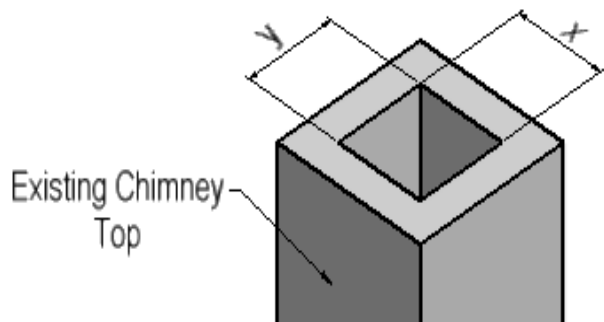

**Installing a Flue System into the Existing Chimney**  
 x & y measurements must be bigger than Flue Diameter K.

**'CAITEC' AIR (Optional - by Installer)**  
 If an adaptor and a stainless steel flue system is fitted to the fire within the existing masonry chimney, then the "CAITEC" blanking plate can be removed. The existing masonry fire place can be vented to an external air supply at the lowest level and the full advantages of :CAITEC' air will be provided.

**Installing a Flue System into the Existing Chimney**

Ensure that the existing Chimney complies with the appropriate Standards & Building Codes.  
 The integrity of the Chimney need to be confirmed by the Installer at the time of installation.  
 If the Chimney is not sound or needs repair then a flue system may be required through the existing masonry chimney. Repair the chimney so that it is structurally sound and prepare the Chimney for a flue system.

**OFFSET ADAPTOR**

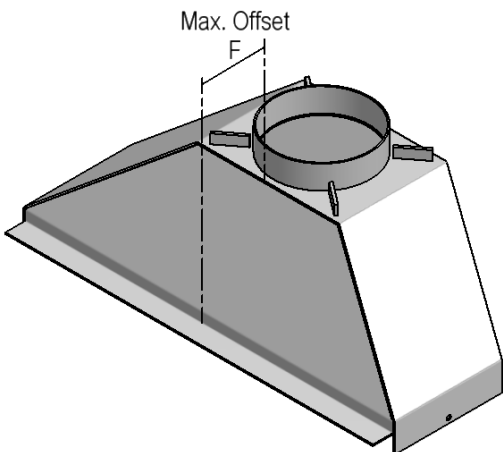

**OFFSET in the Adaptor may be required.**

The offset for the adaptor must not exceed a maximum offset of measurement 'F'. The offset is taken from the original flue centre of the fire system 'J'

**STANDARD ADAPTOR**

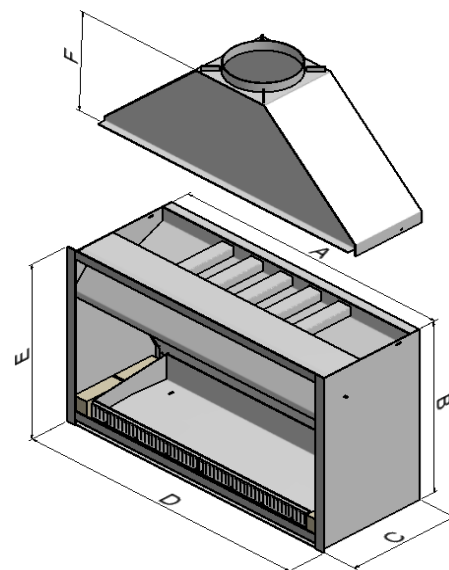

**MEASURING FOR OFFSET ADAPTOR**

Firebox		SI 1250	SI 1500
Adaptor Height -Maximum Offset	F	402	570
Centre of Flue	J	403	403
Flue	K	350	350
Flue Liner	L	450	450

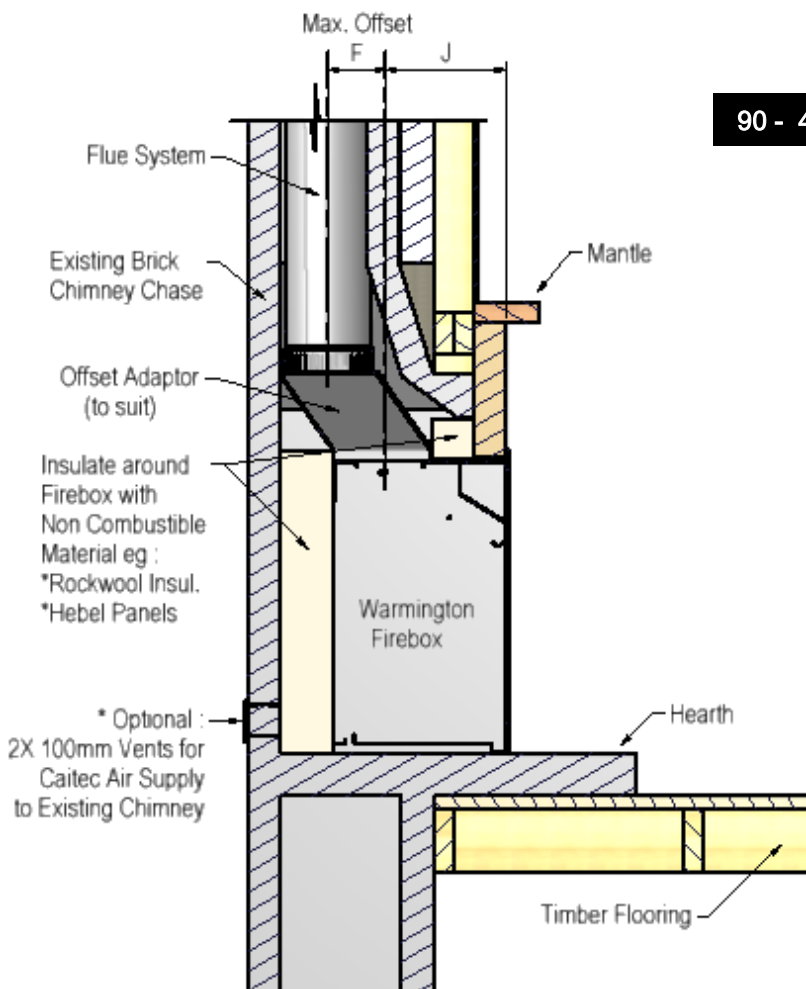

**90 - 45 DEGREE MAX. OFFSET**

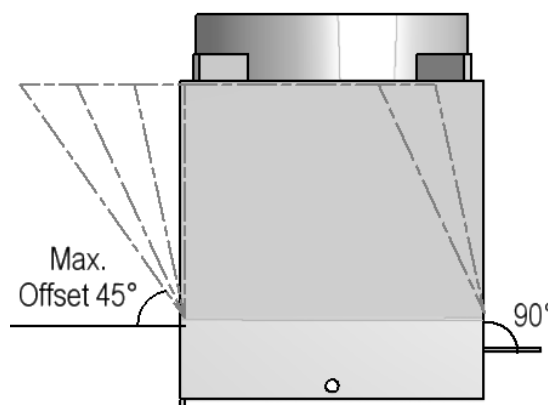

**SIDE VIEW OF STANDARD ADAPTOR**  
Note: The maximum offset.

**MEASURING FOR OFFSET ADAPTOR**

**Standard Flue Centre**

Measurements for standard flue centre 'J' in the table below from firebox (inside) flange to adaptor flue centre.

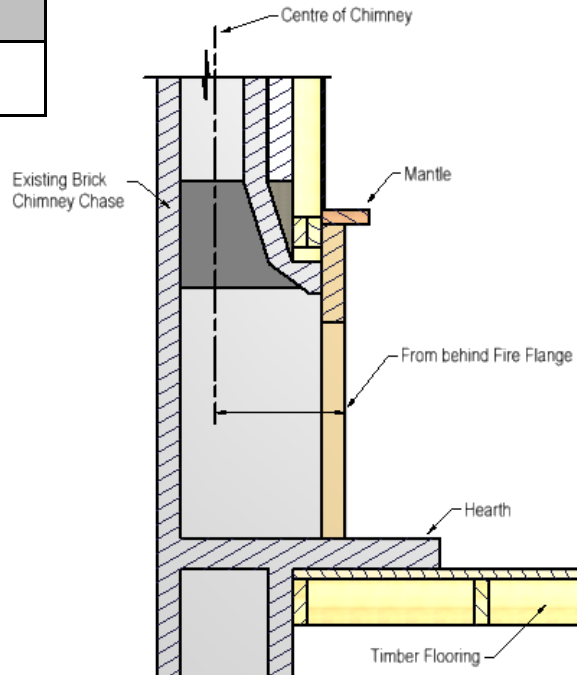
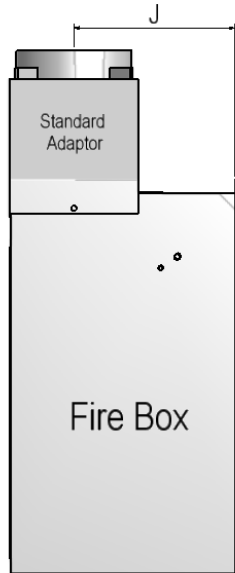

Firebox		SI 1250	SI 1500
Adaptor Height -Maximum Offset	F	402	570
Centre of Flue	J	403	403
Flue	K	350	350
Flue Liner	L	450	450

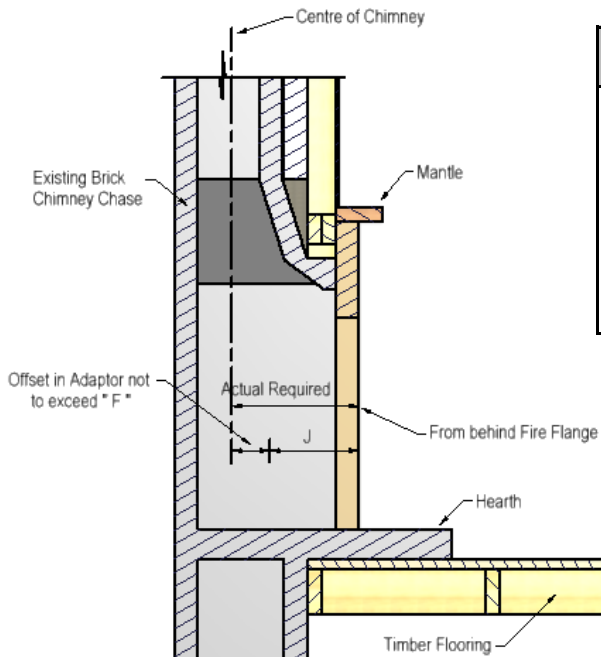

**Chimney Chase Flue Centre**

Measure flue centre from face of mantel opening (inside of firebox flange) to the chimney chase flue centre.

NOTE: If the Warmington fire is not finishing up to the mantel face, then the chimney flue centre is to be taken from behind the Warmington fires flange.

**Offset measurement required**

The offset required to manufacture an offset adaptor is the difference between 'J' & the 'actual required' overall measurement. This must not exceed measurement 'F' adaptor height on previous page.

**COMBUSTIBLE MANTLE CLEARANCES**

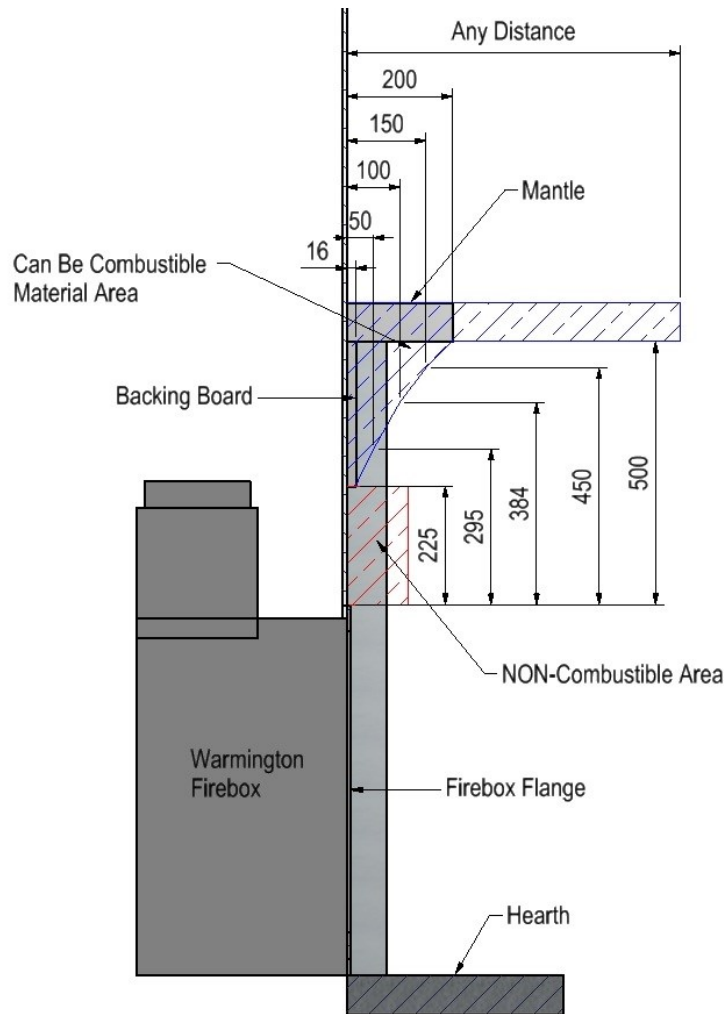
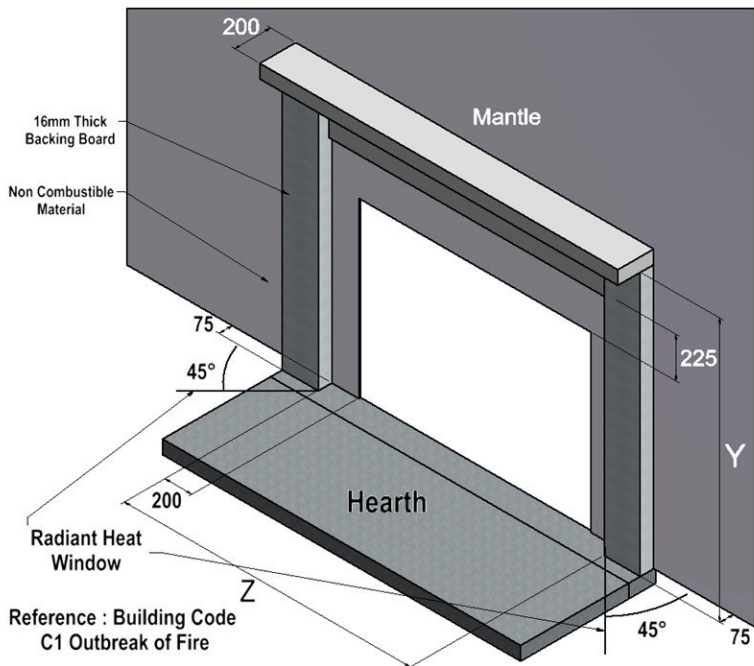

Mantle Clearances		
Firebox	Y	Z
SI 1250 SF	1525	1700
SI 1500 SF	1525	1950

**Note:**  
For combustible floors minimum hearth of 380mm (A) must be maintained.

**RAISED HEARTH CLEARANCES**

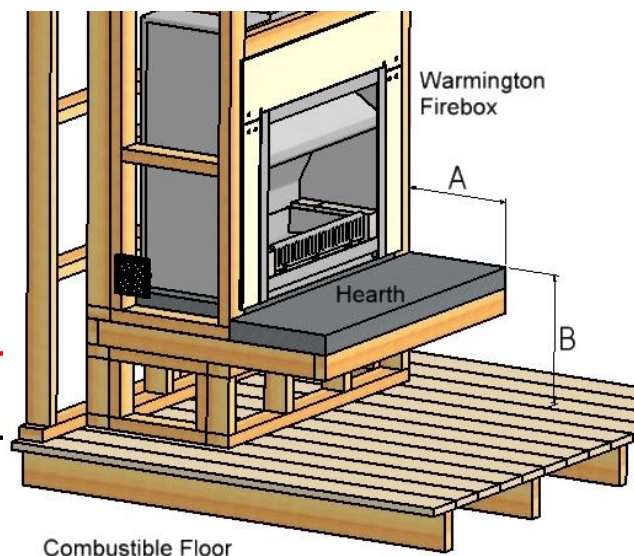
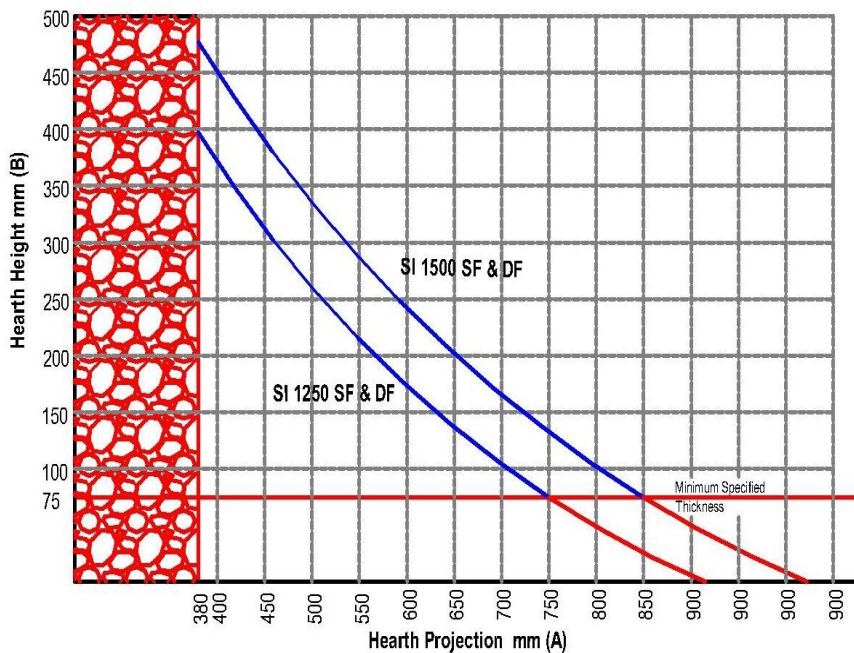

**FLUE HEIGHT MINIMUM DETAILS**

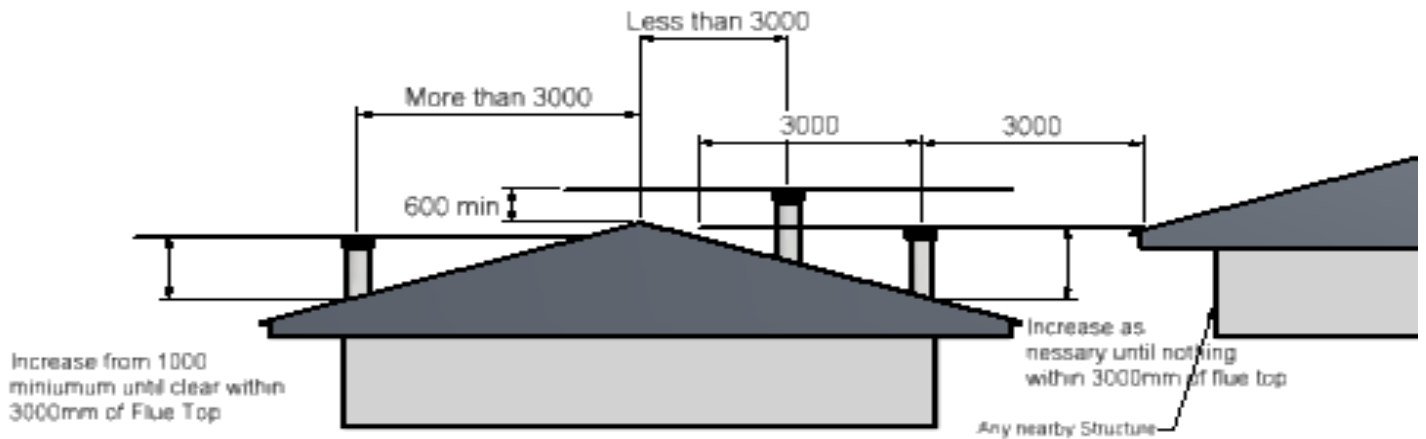

The Flue Penetration is to comply to ASNZS 2918 : 2001

3D View

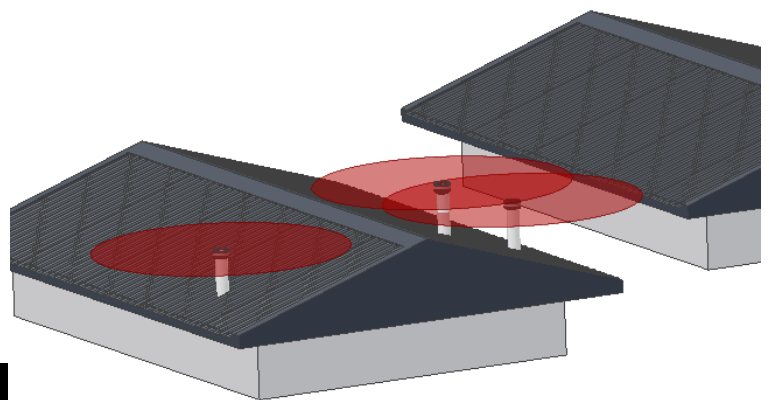

**GENERAL NOTES : ASNZS 2918 : 2001**

**NOTES:**

- Warranty - for full details on product warranties, contact your local Authorised Warmington Retailer.
- For the fire Operational and Maintenance Instructions, visit [www.warmington.co.nz](http://www.warmington.co.nz) and upload the PDF.
- Correct installation, operation and maintenance must be maintained to comply with Warmington Warranty.
- The Appliance and Flue System must be Installed in Accordance with ASNZS2918:2001 and the Appropriate Building codes.
- The Flue System and Fireplace is to be Swept Annually or more frequently if required.

**WARNINGS:**

- **WARNING: ANY MODIFICATION OF THE APPLIANCE THAT HAS NOT BEEN APPROVED IN WRITING BY THE TESTING AUTHORITY IS CONSIDERED AS BREACHING AS/NZS 4013 .**
- **WARNING: DO NOT USE FLAMMABLE LIQUIDS OR AEROSOLS TO START OR REKINDLE THE FIRE .**
- **WARNING: DO NOT USE FLAMMABLE LIQUIDS OR AEROSOLS IN THE VICINITY OF THIS APPLIANCE WHEN IT IS OPERATING .**
- **WARNING: DO NOT STORE FUEL WITHIN HEATER INSTALLATION CLEARANCES .**
- **WARNING: WHEN OPERATION THIS APPLIANCE AS AN OPEN FIRE USE A SPARK SCREEN .**
- **CAUTION: THIS APPLIANCE SHOULD BE MAINTAINED AND OPERATED AT ALL TIMES IN ACCORDANCE WITH THESE INSTRUCTIONS**

Model	Estimated KW	Average KW
1250	30	14
1500	35	14