

SI 780-780T-900-1100 Twin

Twin Open Fires - Wood Burner Installation Instructions into Wood or Block Alcoves

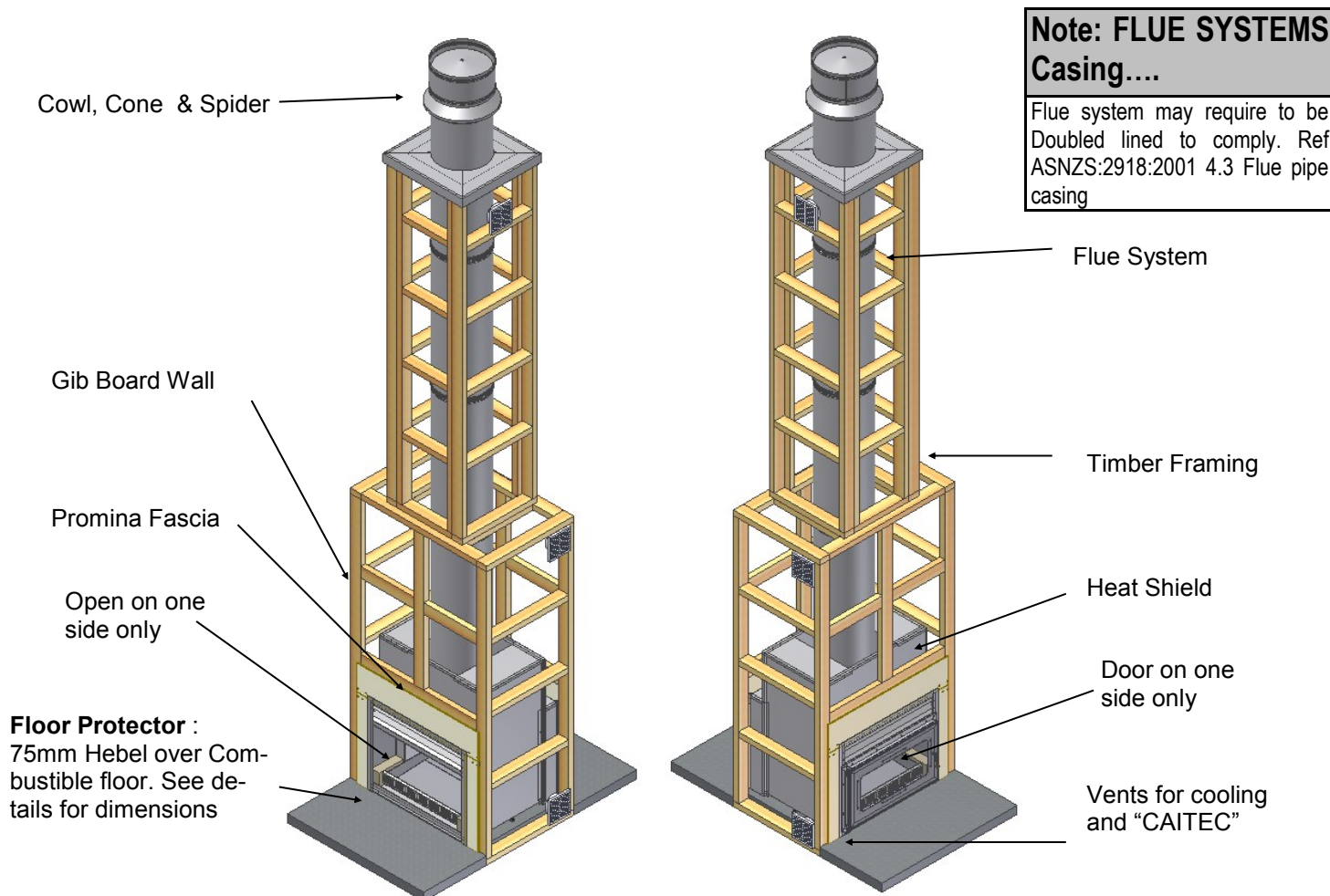

Effective From 1st September 2005

Visit www.warmington.co.nz for Spec's, DWG's and PDF uploads of fires

Fire, Flue System and Instructions to Comply with ASNZS 2918:2001

Keep these Instructions for further reference.....Ensure that you have the correct and current Installation details for the Warmington Fire

Installation

The Warmington unit is to be Installed by a Certified Warmington Installer or an Approved NZHHA Installation Technician .
See www.homeheat.co.nz/members for a Certified NZHHA SFAIT Installer in your area .

IMPORTANT

Read all the Instructions carefully before commencing the Installation. Failure to follow these Instructions may result in a Fire Hazard and void the warranty

POINTS TO CONSIDER PRIOR TO INSTALLATION

Location of the Fire. Open fires are better located at one end of a room or area, as they project the heat away from their opening.

The Topography of the land .

The slope and position of the land in relation to the home has a bearing on how the wind will interact with the fire and flue system. Care needs to be taken to ensure that the flue termination is in the correct position to maximise performance.

The Prevailing Wind.

Care needs to be taken to ensure that the flue termination is in the correct position as wind and gusts that hits the flue and cowl system may overcome the cowl and draft back down the flue into the home. This can be a combination of down draft and high pressure.

Hearth and Plinth:

The Height of the Hearth off the Floor. The Finishing that is to be used on the Hearth is to be allowed for at the design stage.

Note : Ensure Air Intake at Base of Firebox is not blocked or restricted .

Positioning of the Flue System:

There is a maximum distance that an offset flue can be Installed . Reference to AS/NZS 2918:2001 .

Flue And Fire Clearance:

To be maintained to the Manufactures Instructions &/or Comply with appropriate Standards & Building Codes .

Pressure Differential, Venting & External Air into the Building :

All fires need air to burn and draw correctly, Kitchen Fans, Air Conditioning units, High Wind Zones, Naturally forming Draft spaces, can all have an effect on the pressure difference from inside the building to the outside. A lower pressure in the building may induce a draft down the flue system and back into the building causing the fire to smoke or spill into the building. **Care needs to be taken at the design and installation stage to adequately vent the building, or some mechanical system to ensure that there is always a neutral or positive pressure at the fire-place and a negative pressure at the flue outlet.** This will ensure that the draft in the flue system is always to the outside.

“CAITEC AIR” the limits and requirements. See details in these Spec's

Wind Noise:

You may encounter wind noise in some installations. It is recommended to use an enclosed chase with a chimney pot to help reduce noise. There will always be some noise from the flue systems of all fireplaces.

INSTALLATION ORDER OF OPERATIONS

Prior to Construction and Installation Important Notes:

Install to AS/NZS 2918:2001.

Install to manufacture's specifications.

All new installations require a permit.

For special requirements concerning materials (timber mantle and surrounds) within close proximity of Warmington products, please contact your local Warmington Technical Consultant.

Stage 1: Frame Construction Procedure by Builder.

Mark out flue centre.

Mark out heat cell clearance requirements.

Construct plinth only, to required height. *

Stage 2: Install Procedure by Certified “Warmington Installer” only.

Fit fire to plinth.

Fit adaptor to Firebox.

Fit flue system.

Fit cowl and flashing system

Stage 3: Finishing Procedure by Builder.

Construct hearth to required thickness.

* Note: certified installer can install hearth and plinth.

Ensure that the Warmington and flue system is swept annually or more frequently if required.

To sweep flue and firebox:

Cover front of fire with sheets.

Remove cowl from top of chimney.

Sweep from the top, down the flue.

Remove all soot and ash.

Ensure cowl and bird protection is clean and replaced.

Visually inspect fireplace and flue system.

WARMINGTON FIREBOX DIMENSION

| Twin Firebox | | SI 780 | SI 780T | SI 900 | SI 1100 |
|--------------------|-----------|--------|---------|--------|---------|
| Firebox Width | A | 780 | 780 | 900 | 1100 |
| Firebox Height | B | 600 | 680 | 750 | 800 |
| Firebox Depth | C | 700 | 700 | 850 | 900 |
| Flange Width | D | 830 | 830 | 950 | 1150 |
| Flange Height | E | 625 | 705 | 775 | 825 |
| Adaptor Height | F | 205 | 205 | 275 | 275 |
| Cabinet Width | G | 870 | 870 | 990 | 1170 |
| Cabinet Height | H | 1000 | 1000 | 1200 | 1220 |
| Cabinet Depth | I | 680 | 680 | 830 | 880 |
| Centre of Flue | J | 350 | 350 | 425 | 450 |
| Flue | K | 300 | 300 | 325 | 350 |
| Flue Liner | L | 400 | 400 | 425 | 450 |
| Fascia Width | M | 1040 | 1040 | 1160 | 1360 |
| Fascia Height | N | 840 | 925 | 995 | 1045 |
| Heat Output | kW | | | | |
| Peak* | | 24 | 26 | 32 | 35 |
| Range* | | 15-17 | 17-19 | 18-21 | 19-22 |

*Estimated unless stated otherwise.

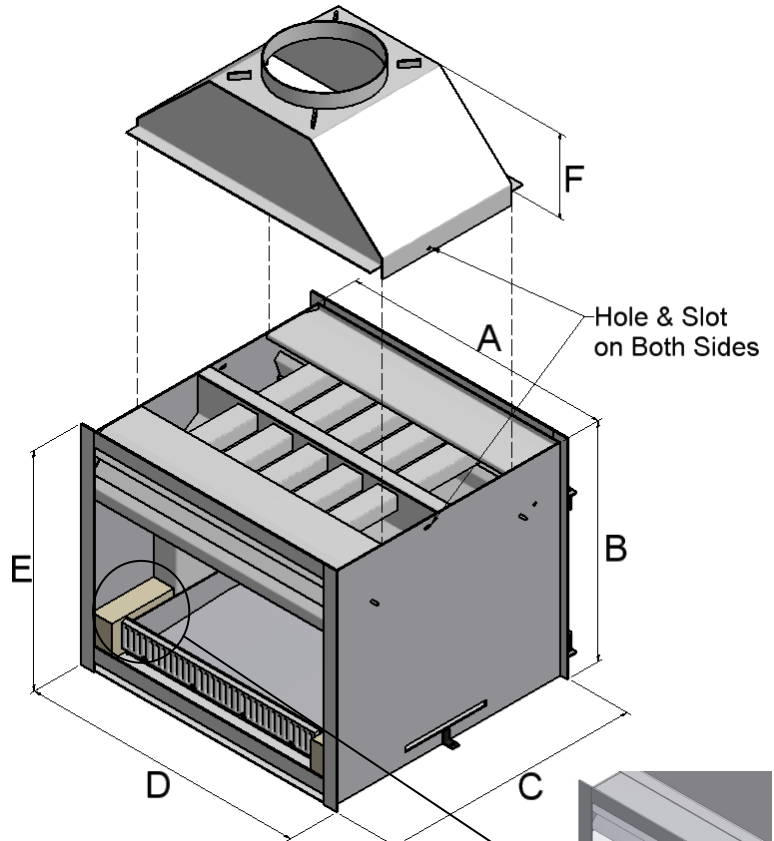

FIREBOX HEAT CELL CABINET

| | |
|------------------------------|--------------|
| Minimum Flue Height | |
| Flue Height | 4800 |
| Measured From Top of Adaptor | B + F + 4800 |

Adaptor Fitting

Seal adaptor to firebox using high-temp gasket sealant. Bolt through holes provided.

Seismic restraint

Secure firebox through anchor positions provided.

Check List

| | |
|----------------------|--|
| Firebox | |
| Adaptor (Fastenings) | |
| Ash pan | |
| Bricks | |
| Louvers | |
| Badge | |
| Damper Handle | |
| Packed By | |

Note:
DO NOT FRAME OUT TO THESE DIMENSIONS
CHECK HEAT CELL ALCOVE ON PAGE 5 & 6.

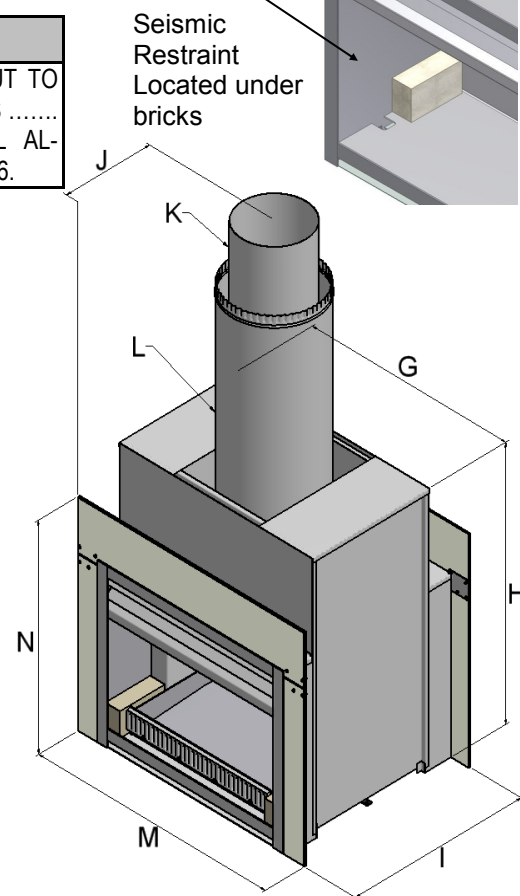
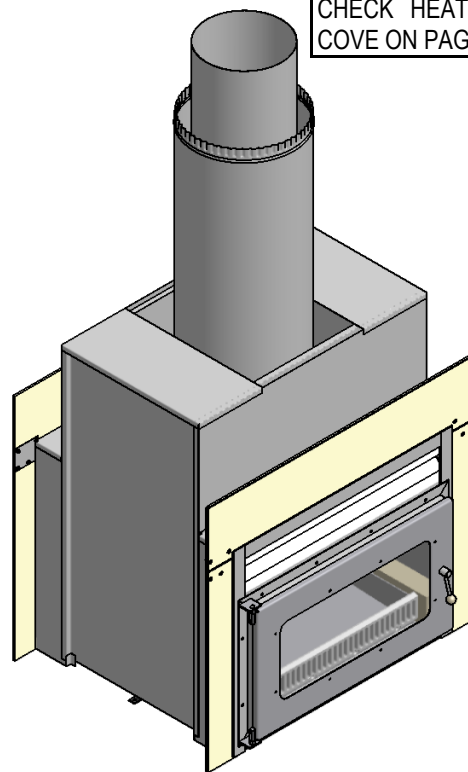

Showing sides with and without door fitted

FIREBOX INSTALLATION

This is a general installation guide only – Contact a “NZHHA Installer” for Installation Advice or go to www.homeheat.co.nz then select **Members** select your **Region** - **Installers** - **Woodburner** & **Search** to find a Certified Installer in your Region.

1. All the dimensions are minimums
2. Fit the Plinth into position in the Cavity. If onto a wooden floor ensure that an insulating plinth is fitted as per the specifications. **Ensure that the plinth is elevated to allow for finishing on the hearth. (See Hearth and plinth details)**
3. Assemble back panel and sides of the heat shield, position into Cavity.
4. Fit the firebox into the Cavity, allow for the Fascia to fit behind the flange and to the timber framing. (Approx 10mm) Bolt the fire box to the plinth or through to the floor with the bolting point provided on the Left and Right hand sides of the fire box (seismic restraints).
5. Fit the Adaptor to the Fire box. Ensure that exhaust sealant is used between the fire and Adaptor. Bolt into position with the bolt in the Left and right hand sides of the Fire box.
6. Install the flue system.
7. Fit the front of the heat shield and rivet into position. Fit Lintel cap and Caps to the heat shield.
8. Fit the Fascia kit between the heat shield and behind the firebox flange. This fitment will be firm and will complete the shielding around the fire system.

HEARTH & PLINTH CONSTRUCTION DETAILS

IMPORTANT NOTE :

| |
|---|
| Note: Hearth and Plinth Construction. |
| For Combustible Flooring an Insulating Hearth and Plinth of 75mm Hebel is required . |
| Plinth to be Offset above Hearth by the Hearth Finishing's (e.g. Tiles / Granite / Solid plaster / etc) |

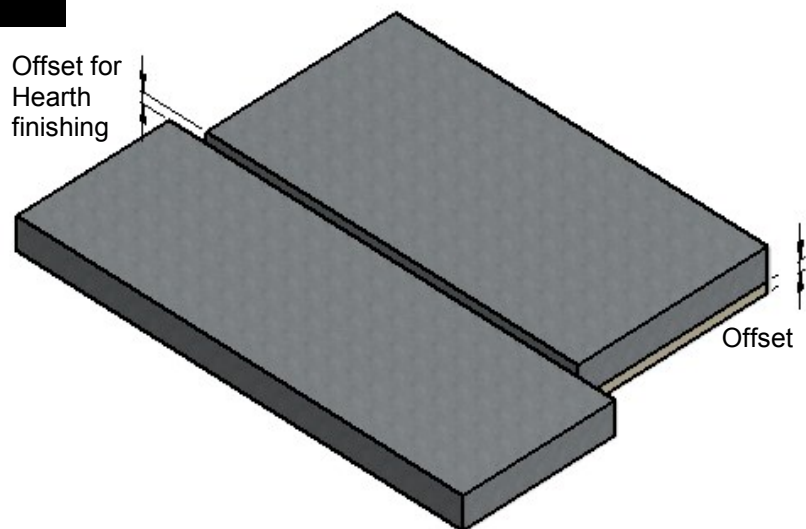

***Note: If Solid Plastering the Heat Cell structure, it is recommended to use a Fibreglass Mesh with a Latex Based Plaster to minimise the chance of the Solid Plaster cracking. (See your Solid Plasterer for correct materials and applications).**

Visit the Warmington Web Site for “Hebel” instruction (PDF Download).. www.warmington.co.nz

“CAITEC” TECHNOLOGY—ROOM AIR REPLACEMENT

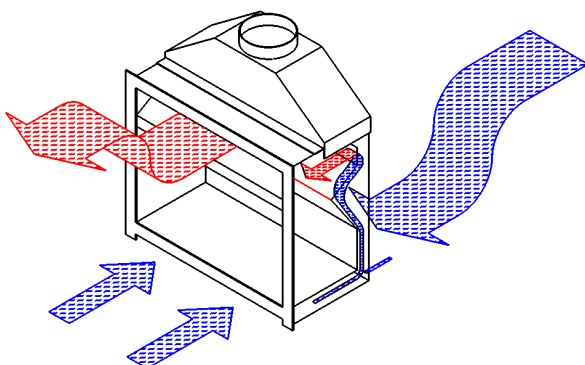

Caitec draws air from an external air source to ensure that the open fire has pre-heated combustion air maximising efficiency while maintaining the home at constant pressure equilibrium, reducing the risk of back drafting .
 Ensure that the cavity is vented to Outside fresh Air and the Warmington will take care of the rest. 2 x 100mm Diameter vent are required (Or equivalent to that.)
Builder to supply external air to the Cavity and the “Warmington Fire” takes care of the rest.

NOTE: Points to Consider regarding Pressure Differential.

TIMBER FRAMING & TRIM OUT DETAILS

| Twin Firebox | | SI 780 | SI 780T | SI 900 | SI 1100 |
|----------------------------|---|--------|---------|--------|---------|
| Heat cell Clearance Width | O | 1000 | 1000 | 1100 | 1350 |
| Heat Cell Clearance Depth | P | 680 | 680 | 830 | 880 |
| Heat Cell Clearance Height | Q | 1700 | 1700 | 2400 | 2400 |
| Hearth Width | R | 1200 | 1200 | 1350 | 1550 |
| Hearth Projection | S | 600 | 600 | 600 | 600 |
| Window Height | V | 825 | 905 | 975 | 1025 |
| Window Width | W | 1000 | 1000 | 1100 | 1350 |
| Chimney Chase Clearance | X | 500 | 500 | 525 | 550 |

MINIMUM HEAT CELL ALCOVE CLEARANCES & FRAME OUT

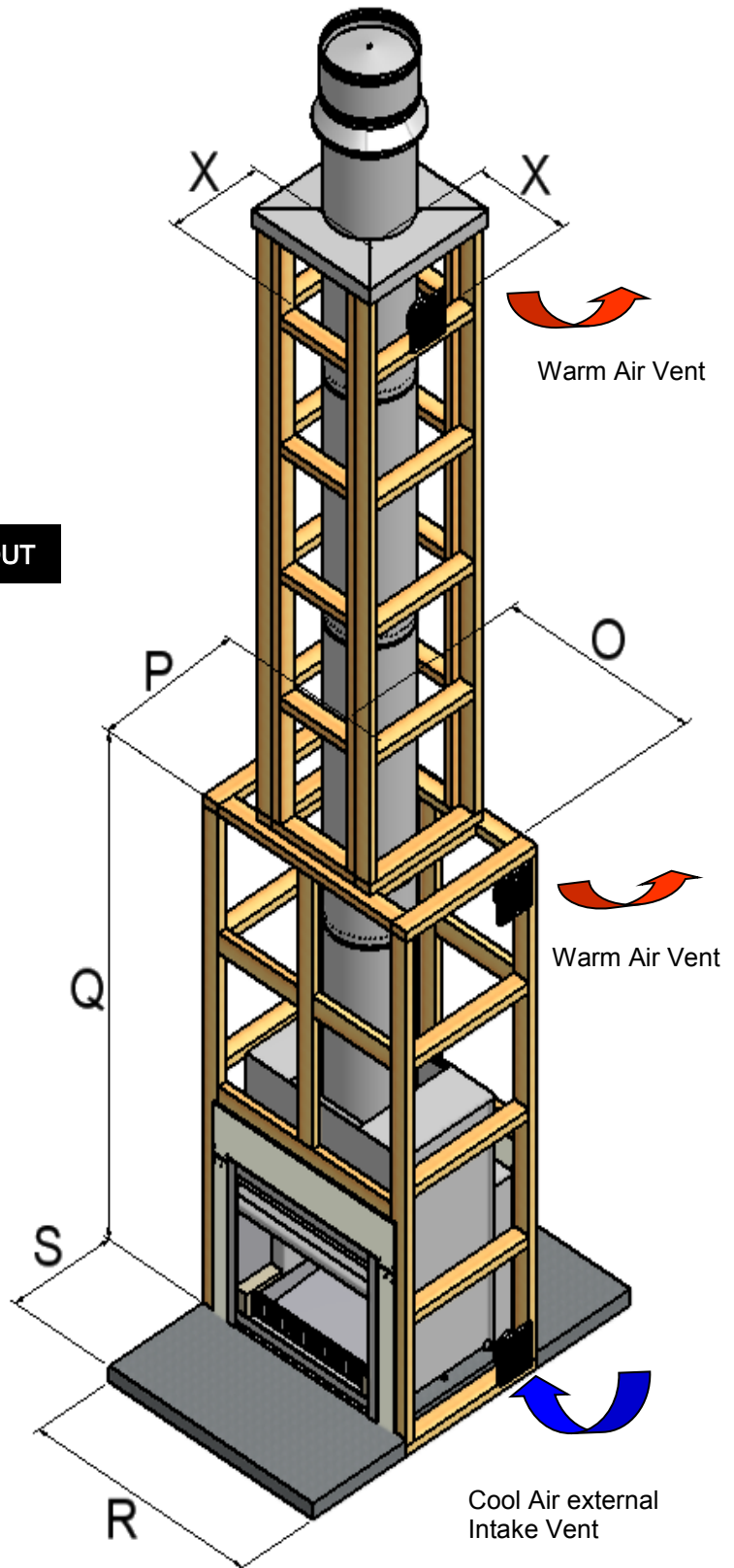
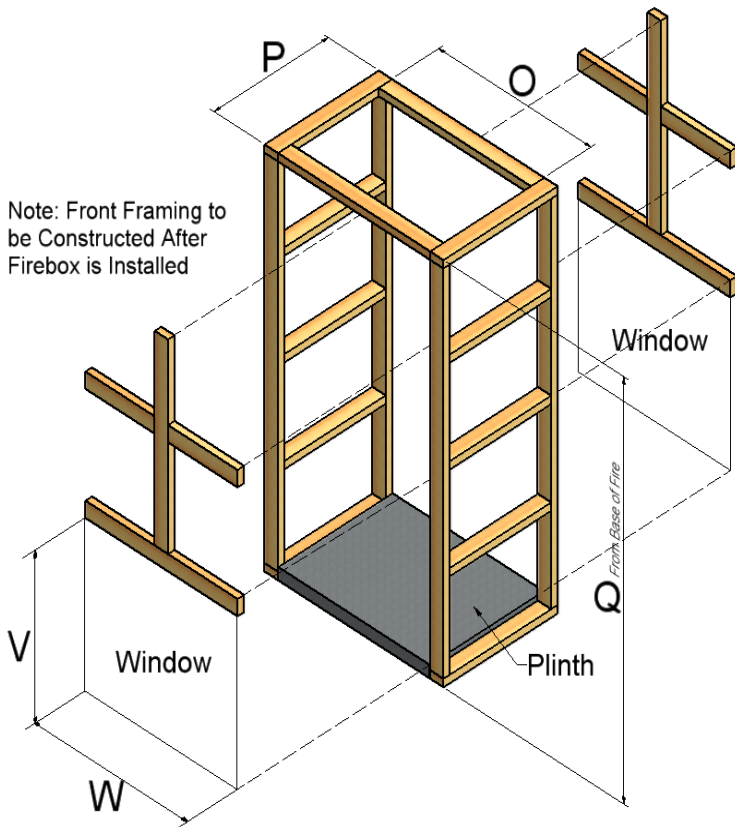

Note:
All Framing Dimensions are Internal Only

Note:
Check centre Line of Flue

TIMBER : PLAN, FRONT ELEVATION & CROSS SECTION

| Firebox | | SI 780 | SI 780T | SI 900 | SI 1100 |
|-------------------------|---|--------|---------|--------|---------|
| Hearth Width | R | 1200 | 1200 | 1350 | 1550 |
| Hearth Projection | S | 600 | 600 | 600 | 600 |
| Plinth Width | T | 1000 | 1000 | 1100 | 1350 |
| Plinth Depth | U | 680 | 680 | 830 | 880 |
| Centre of Flue | J | 350 | 350 | 425 | 450 |
| Chimney Chase Clearance | X | 500 | 500 | 525 | 550 |

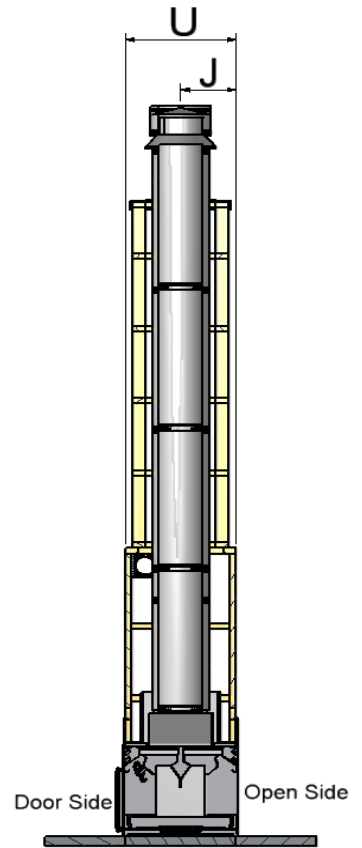
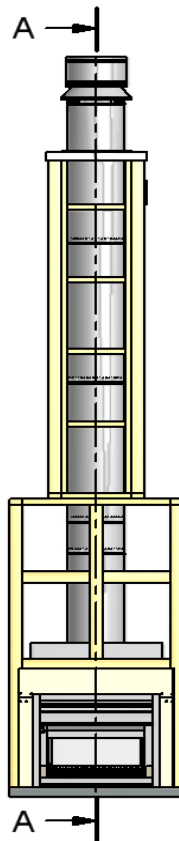
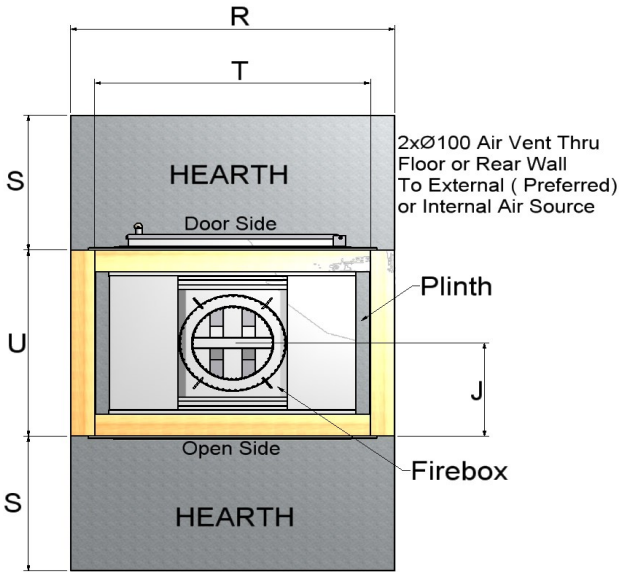

BLOCK : PLAN, FRONT ELEVATION & CROSS SECTION

| Firebox | | SI 780 | SI 780T | SI 900 | SI 1100 |
|-------------------------------|----|--------|---------|--------|---------|
| Hearth Width | RR | 1200 | 1200 | 1350 | 1550 |
| Hearth Projection | SS | 600 | 600 | 600 | 600 |
| Plinth Width | TT | 810 | 810 | 1210 | 1210 |
| Plinth Depth (NOT BLOCK WORK) | UU | 680 | 680 | 830 | 880 |
| Centre of Flue | JJ | 350 | 350 | 425 | 450 |

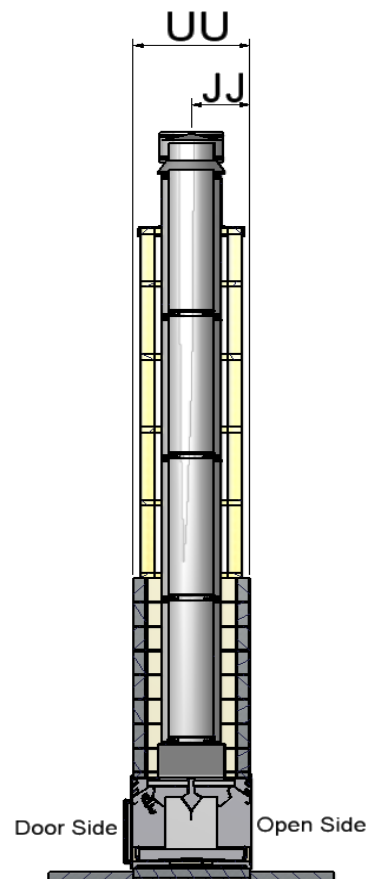
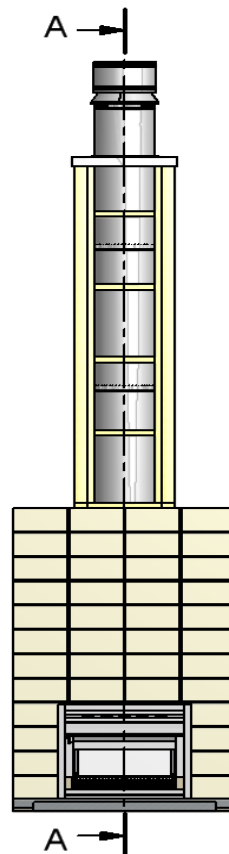
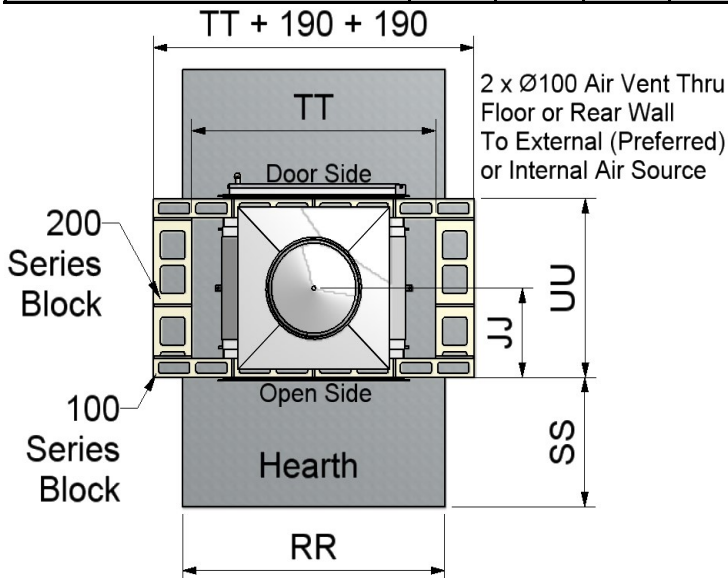

BLOCK ALCOVE & TRIM OUT DETAILS

| Firebox | | SI 780 | SI 780T | SI 900 | SI 1100 |
|--|----|--------|---------|--------|---------|
| Heat cell Clearance Width | OO | 1000 | 1000 | 1210 | 1210 |
| Heat Cell Clearance Depth (BLOCK WORK) | PP | 680 | 680 | 830 | 880 |
| Heat Cell Clearance Height | QQ | 1700 | 1700 | 2400 | 2400 |
| Hearth Width | RR | 1200 | 1200 | 1350 | 1550 |
| Hearth Projection | SS | 600 | 600 | 600 | 600 |
| Window Height | VV | 615 | 695 | 765 | 815 |
| Window Width | WW | 810 | 810 | 930 | 1130 |
| Chimney Chase Clearance | XX | 500 | 500 | 525 | 550 |

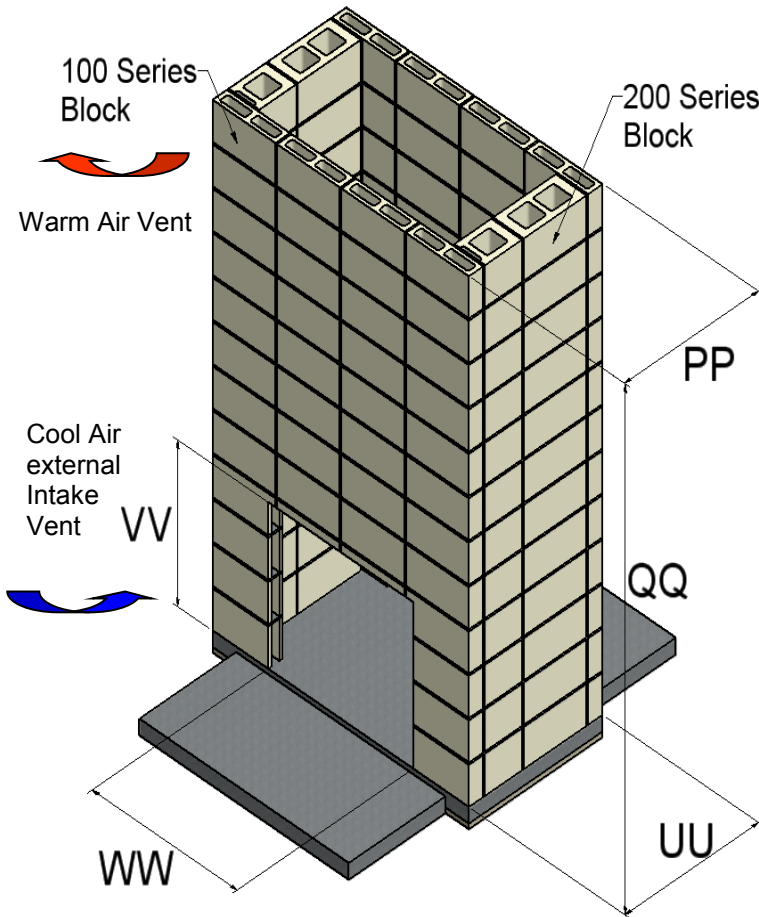

MINIMUM HEAT CELL BLOCK ALCOVE CLEARANCES

Note:
 Ensure that the Fire and Flue System is Installed before the alcove access is blocked off .
 Block modules may vary to the drawing .

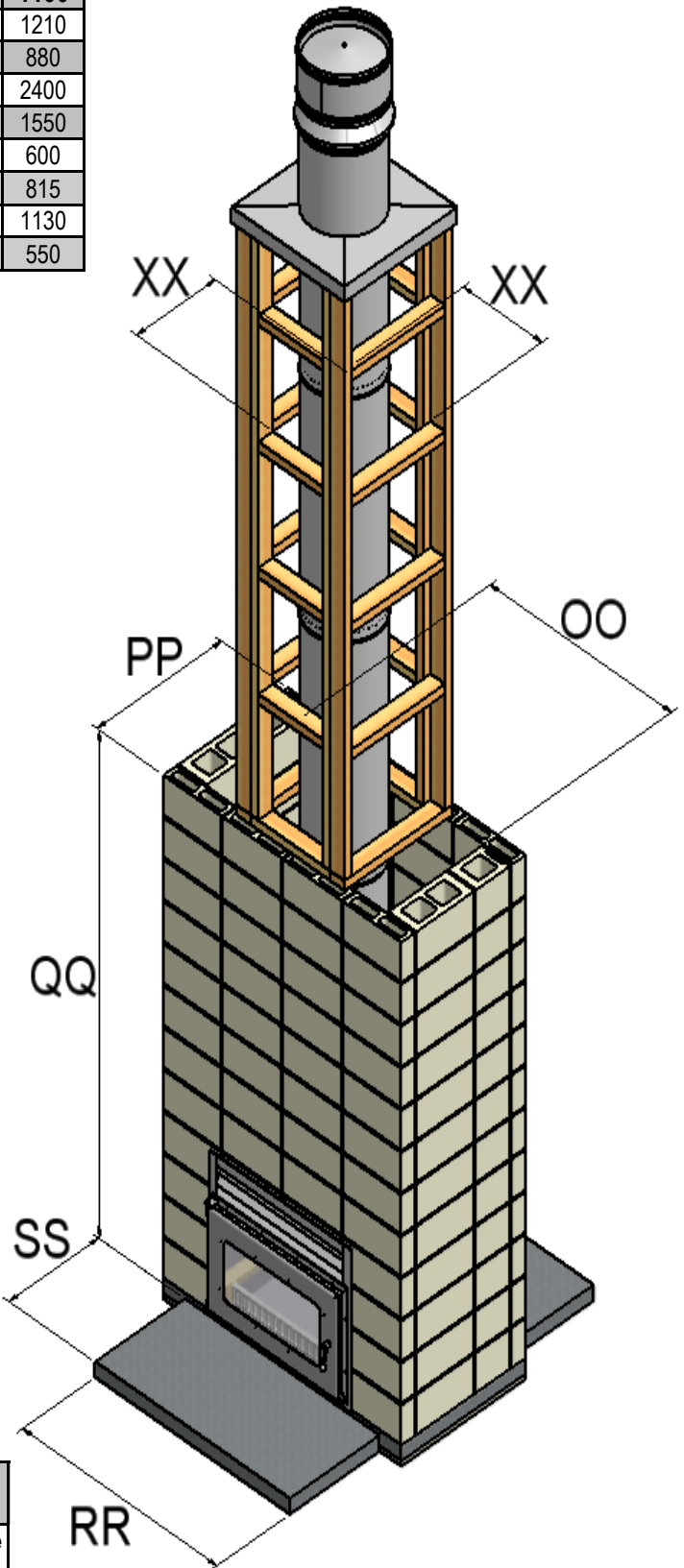

HEAT SHIELD ASSEMBLY

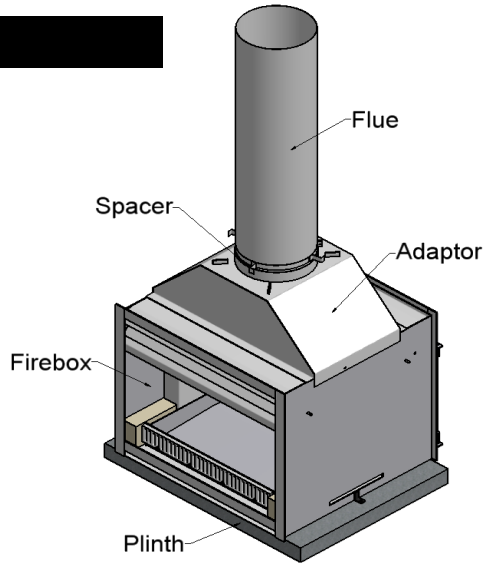
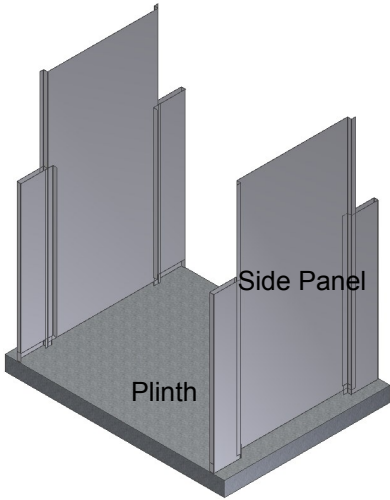

Heat Shield Assembly : Step 1

Method:
If fitting fascia kit go to note 'A' on fascia kit assembly before "Step 2"

Heat Shield Assembly : Step 2

Method:
1) Sit firebox into position and fix down. Assemble adaptor and flue system according to AS/NZS 2918:2001.
2) Fix front panel on by insuring the location tag is positioned at the top of the side panels. Clamp, secure and rivet front panel to side panels as shown.
OPTIONAL: - If unable to rivet to the side panel , screw front panel from front face.....screws provided.

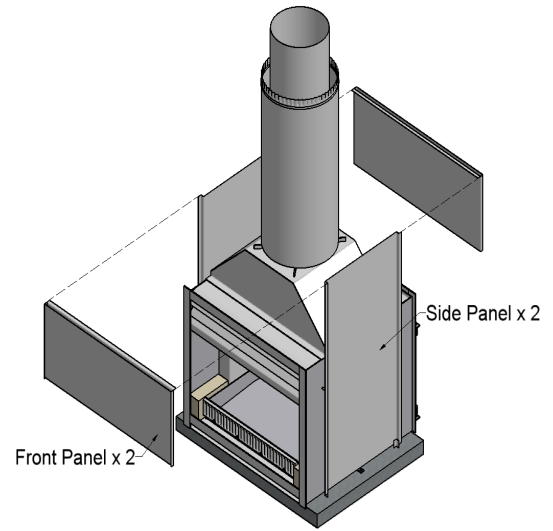
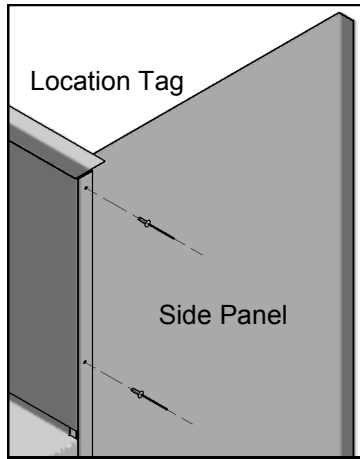

Heat Shield Assembly : Step 3

Method:
Slide flue liner over flue and locate on spacer lugs .
Place top caps on the edge of the assembled sides, clamp, secure and then rivet them together

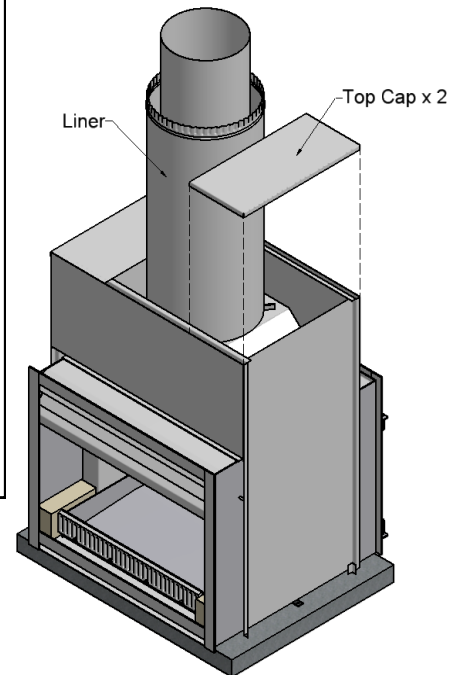
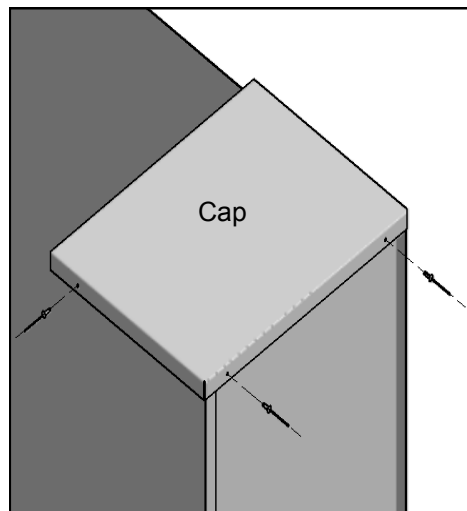

| Heat Shield Check List | | |
|--------------------------|---|--|
| Packet Screws...Optional | 1 | |
| Front Panel | 2 | |
| Side panel LH | 1 | |
| Side panel RH | 1 | |
| Top Cap LH | 1 | |
| Top Cap RH | 1 | |
| Packed By | | |

FASCIA ASSEMBLY

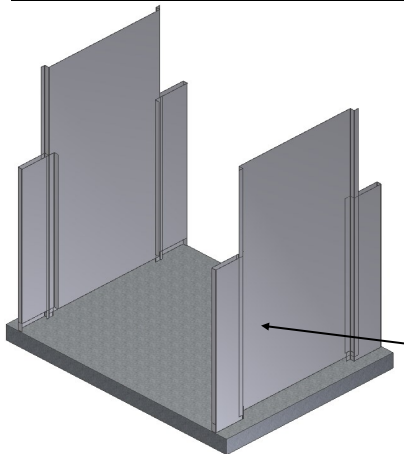

Note 'A' Method
 Locate wing to front base edge of side panel, secure and rivet together.

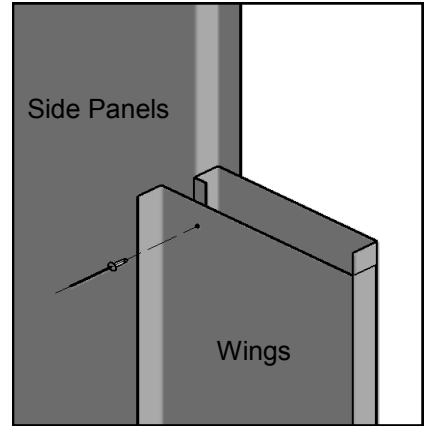

Note 'B' Method
 Fit lintel cap 20mm kick in behind front panel, secure and rivet together.

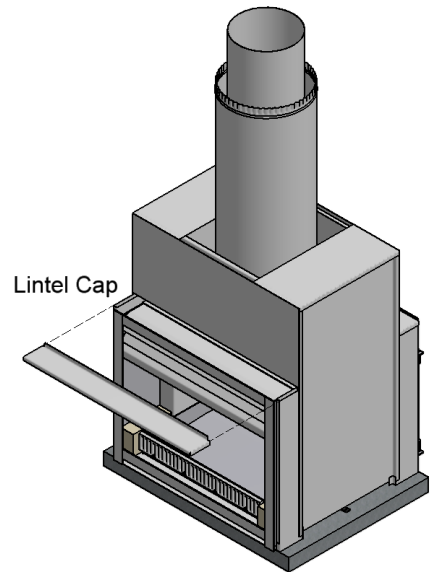
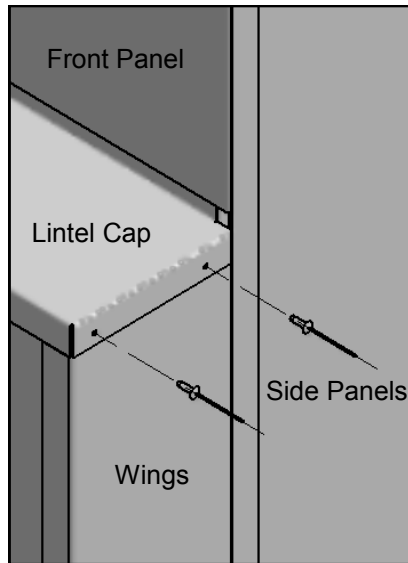
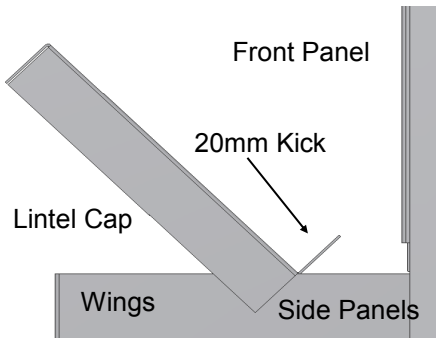

Note 'C' Method
 Assemble together fascia side panels and top panel using fastenings provided. Slide fascia down the front flange into position no less than 15mm overlap on each side.

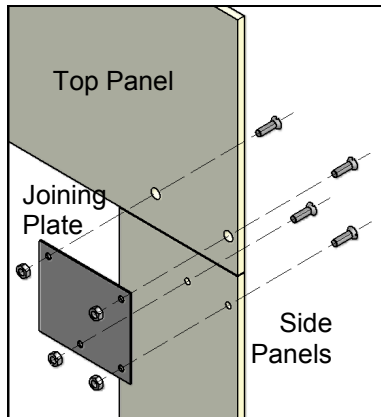

Note '4' Fixing Fascia to Frame
 Drill hole through Fascia approximately 200mm apart, screw assembled fascia into timber securing in place.

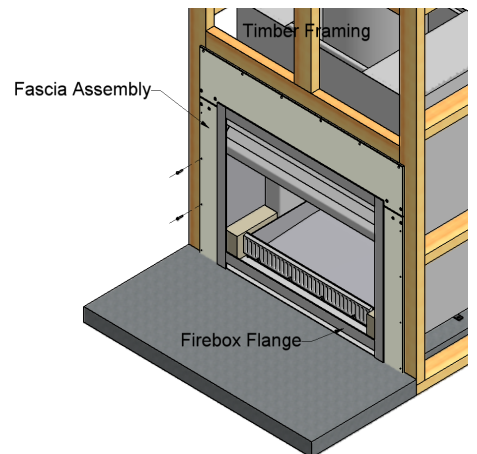
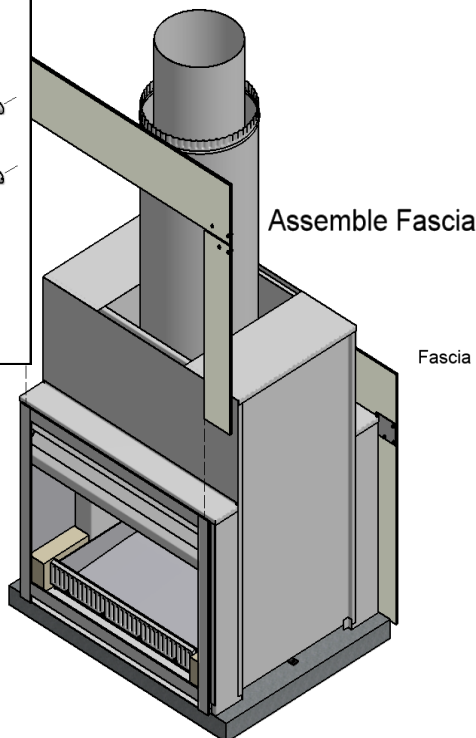

| Check List | No: | Tick |
|-----------------------|-----|------|
| Fastenings | 4 | |
| Promina Top Panel | 2 | |
| Promina Side panel LH | 2 | |
| Promina Side panel RH | 2 | |
| Lintel Cap | 2 | |
| Wing LH | 4 | |
| Wing RH | 4 | |
| Packed By.....Sign | | |

FLUE DETAILS DIMENSIONS

| | |
|------------------------------|--------------|
| Minimum Flue Height | |
| Flue Height | 4800 |
| Measured From Top of Adaptor | B + F + 4800 |

| Flue details | No: | SI 780 | SI 780T | SI 900 | SI 1100 |
|----------------|-----|---------|---------|---------|---------|
| Cowl | 1 | 300 | 300 | 325 | 350 |
| Cone | 1 | 300 | 300 | 325 | 350 |
| Top Spider | 1 | 300 | 300 | 325 | 350 |
| Flue Diameter | 4 | 300 | 300 | 325 | 350 |
| Liner Diameter | 4 | 400 | 400 | 425 | 450 |
| Spacer | 4 | 300/400 | 300/400 | 325/425 | 350/450 |

NOTE:
Ensure that a Standard Tested Warmington Flue system is used on the Warmington fires.

FLUE SYSTEM INSTALLATION GUIDE

This is a general installation guide only – Contact a “NZHHA Installer” for Installation Advice.

1. Install the first length of flue pipe with the crimped end down, inside the Adaptor collar, ensure that the flue pipe is sealed into the collar with exhaust sealant. Rivet the flue in 3 places around the Adaptor collar. Place a spacer around the flue pipe approximately 150mm above the adaptor collar. Secure in position by tightening the screw and nut.
 2. Install the second length of flue pipe with the crimped end down and fit by riveting in at least 3 places around the flue pipe joint. Ensure that the flue is sealed into position with sealant.
 3. Install the first section of flue pipe liner with the Crimped end up, over the flue pipe and over the spacer that is fixed to the flue pipe. This spacer will keep the liner concentric about the flue pipe.
 4. Position flue spacer at the flue pipe joint for every length of “Flue pipe” and “Liner”.
- Repeat the Steps from 1 – 4 to the installed required height of the flue system. The flue system is to comply with ASNZS 2918:2001 4.9.1

- a “the flue pipe shall extend not less than 4.6m above the top of the floor protector.”
- b “the minimum height of the flue system within 3 m distance from the highest point of the roof shall be 600mm above that point.”
- c “the minimum height of the flue system further than 3 m from the highest point of the roof shall be 1000mm above the roof penetration.”
- d “no part of any building lies in or above a circular area described by a horizontal radius of 3 m about the flue system exit.”

1. **NOTE:** The last length of flue pipe needs to extend past the liner so that when the “top spider” and the “Flashing cone” are fitted, that the “flashing cone” and the “flue pipe” are **flush**, or that the “flue pipe” is **5mm lower** than the “Flashing cone”.
2. Fit the “Top Spider” into position, ensure that the legs of the spider are fitted inside the liner and that the spider is positioned hard down onto the liner and tighten with the screw and nut.
3. Place the “Flashing cone” over the “flue pipe” and press hard down onto the “Top Spider”. (Note that the “Flue pipe” and the “Flashing Cone” are either flush or the “Flue pipe” is 5mm Lower than the “Flashing cone”.) Ensure that the “Flashing cone” is clear for the venting from the “Liner” and the “flue pipe”.
4. Fit the “Cowl” to the top of the flue pipe. The “Cowl”, “Flashing cone”, and the “Flue pipe” can be secured to each other with the uses of a stainless steel self tapping screw. This will allow the “Cowl” to be removed for cleaning.
5. Flue system may require Bird Proofing due to the installation and locations, discuss this with your installer for the best advice.
6. If the Flue system is installed into a “Chimney Chase”, allow for air vent as close to the top of the chase as practical, or allow venting through the “Chimney Chase Flashing”. A “Venting Flashing cone” and a 25mm gap around the Liner with a “Venting Flashing Cone-Spider” can be used. Ref : to Figures

Note: FLUE SYSTEMS Casing....

Flue system may require to be Doubled lined to comply.
Ref ASNZS:2918:2001 4.3 Flue pipe casing

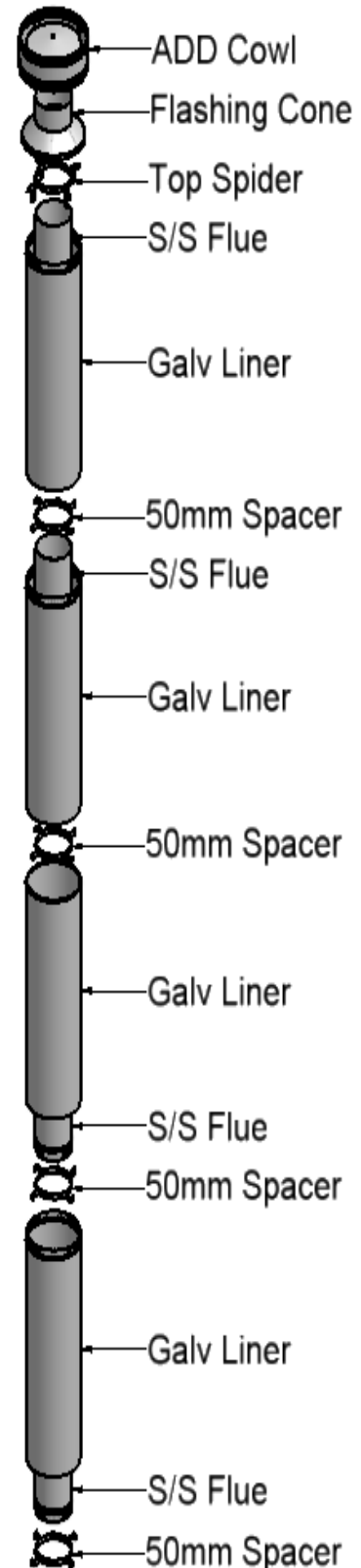

FLUE PENETRATION Vented through Alcove (Single lined Flue System)

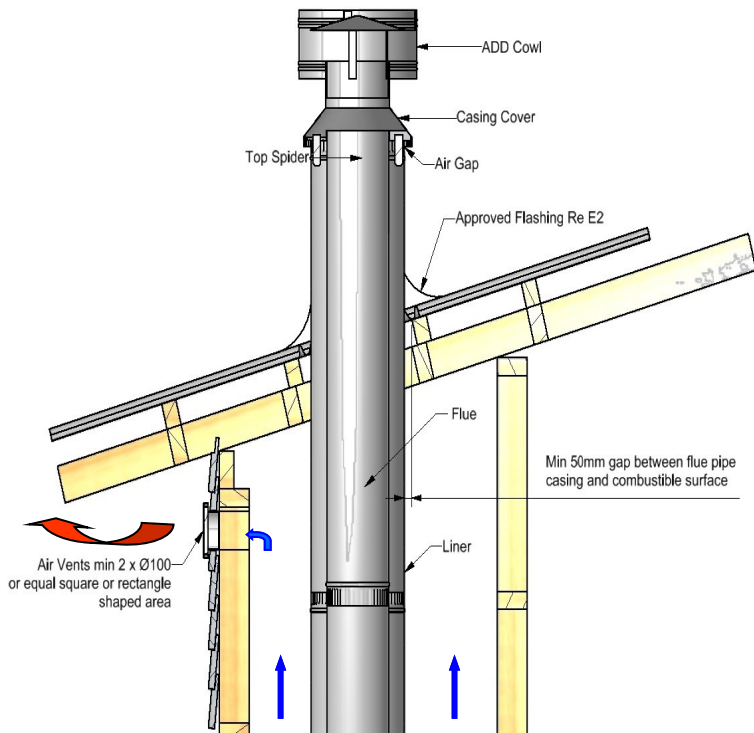

FLUE PENETRATION Vented through Alcove (Double lined Flue System)

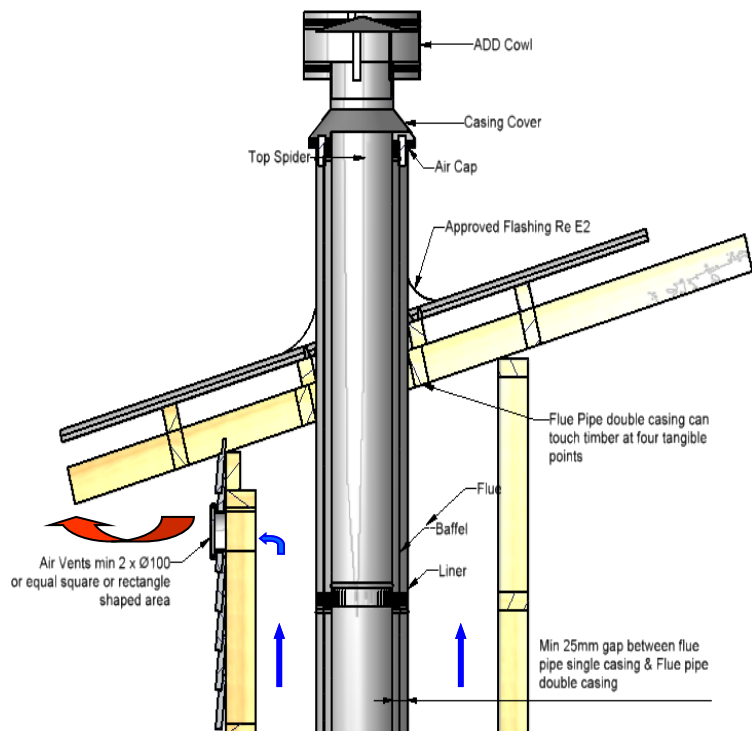

FLUE PENETRATION Vented through Top Flashing

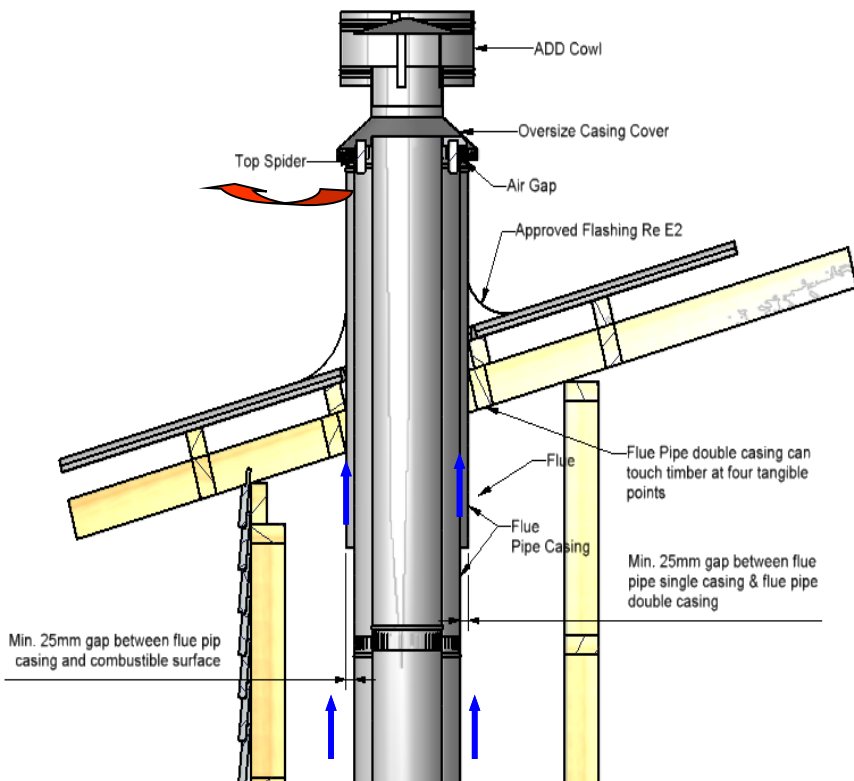

Note: FLUE SYSTEMS Casing....
 Flue system may require to be Doubled lined to comply.
 Ref ASNZS:2918:2001 4.3 Flue pipe casing

Note :

External Requirements
 Refer to AS/NZS2918:2001 4.9.1

Install Flue system to AS/NZS2918:2001

When using a rubber or Bitumen flashing (Butynol, Dectite) an Additional Flue pipe Baffle is required.

All external air vents & ceiling penetrations must be bird proofed with permanently fixed screens.

All flashing to comply with E2.

All external air vents and ceiling penetrations are to be Vermin and Rodent proof.

| Test Report Number | Date of Report |
|--------------------|----------------------------|
| 04/1039 | 20 th July 2004 |
| 04/1040 | 20 th July 2004 |
| 04/1041 | 20 th July 2004 |

CHIMNEY CHASE FLASHING DETAILS

SETTING ADD COWL AND FLASHING CONE HEIGHT

General Chimney Chase Flashing Lay Out

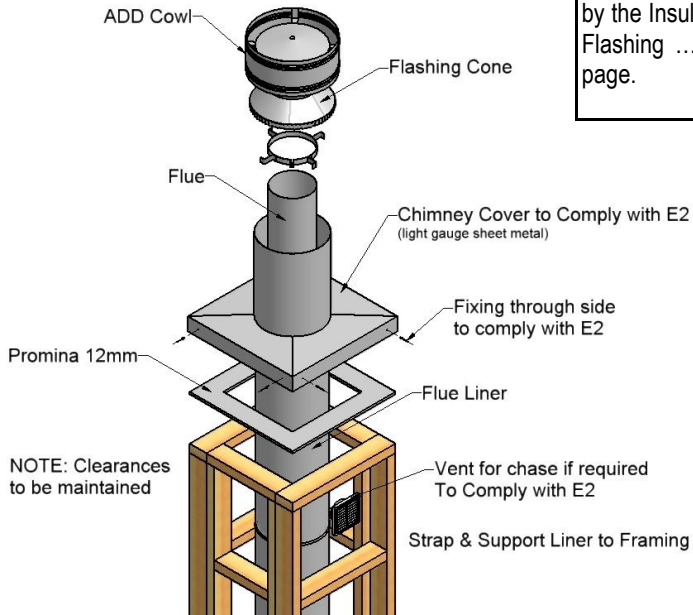

Note:
Flashing Spigot height is determined by the Insulation that is fitted under the Flashing ... See Details at bottom of page.

STEP 1

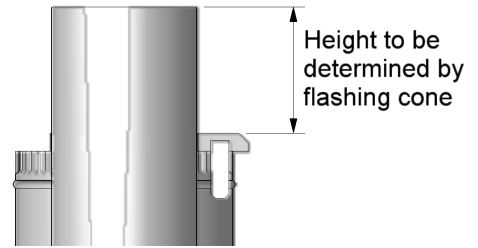

STEP 2

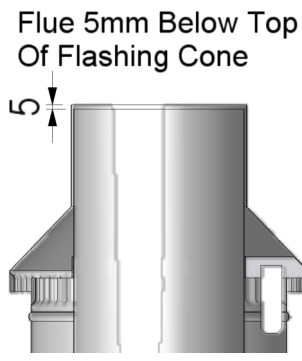

STEP 3

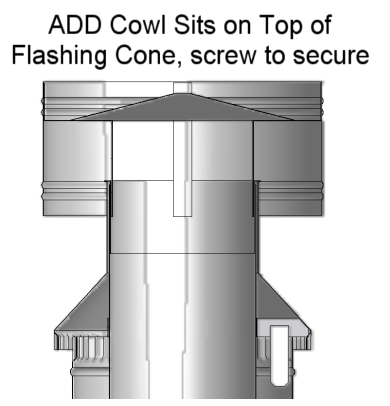

“CHIMNEY CHASE FLASHING” AND “AIR VENTILATION” OPTIONS :

VENTING THROUGH CHIMNEY CHASE

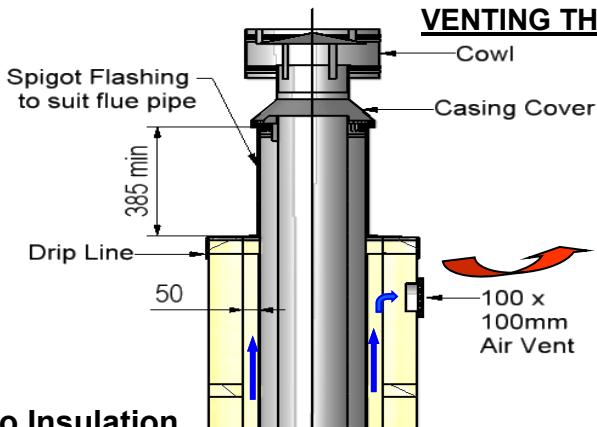

“No Insulation under flashing”

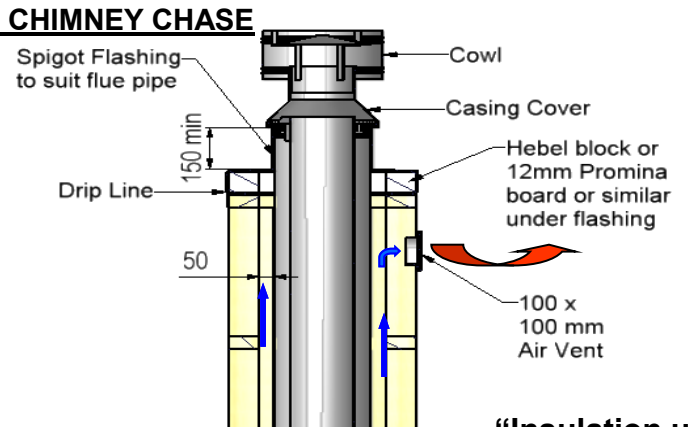

“Insulation under flashing”

VENTING THROUGH FLASHING

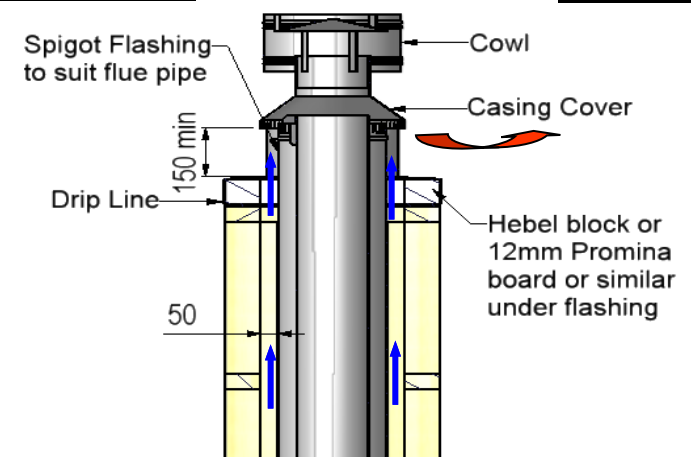
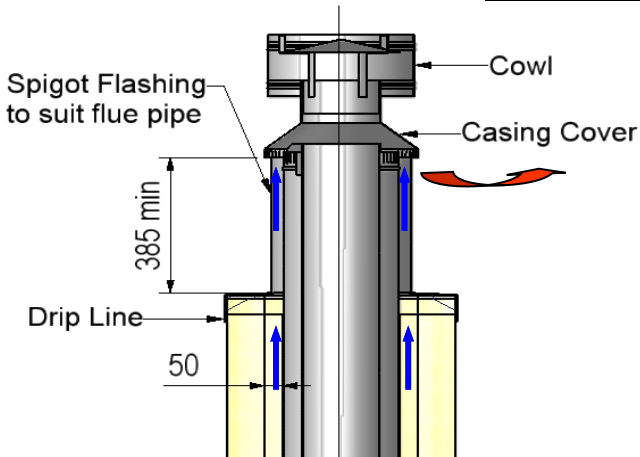

FLUE HEIGHT MINIMUM DETAILS

Note: FLUE SYSTEMS Casing....
 Flue system may require to be Doubled lined to comply.
 Ref ASNZS:2918:2001 4.3 Flue pipe casing

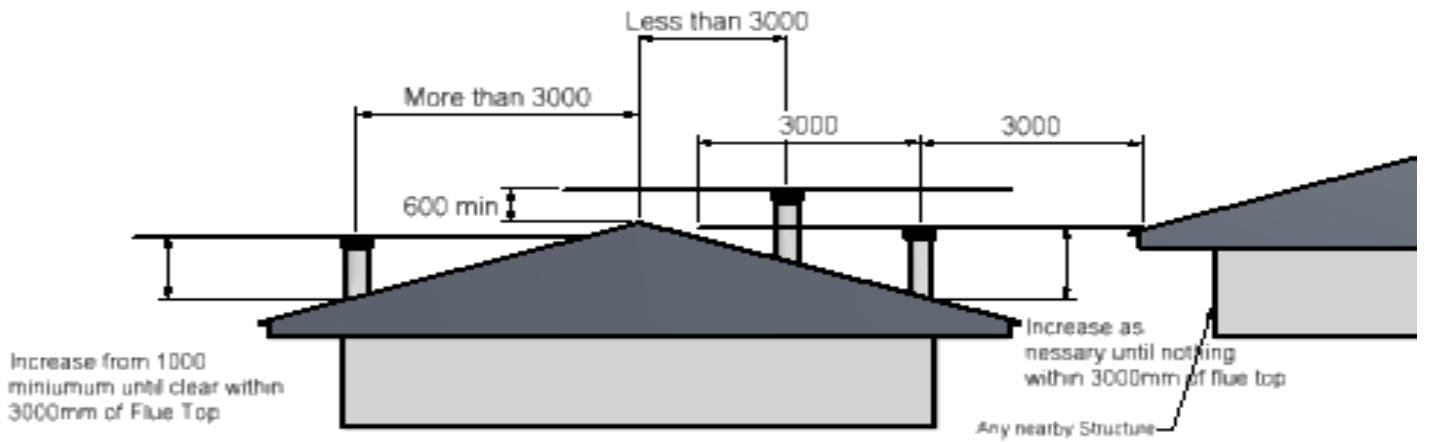

The flue exit is to comply to ASNZS 2918 :

3D View

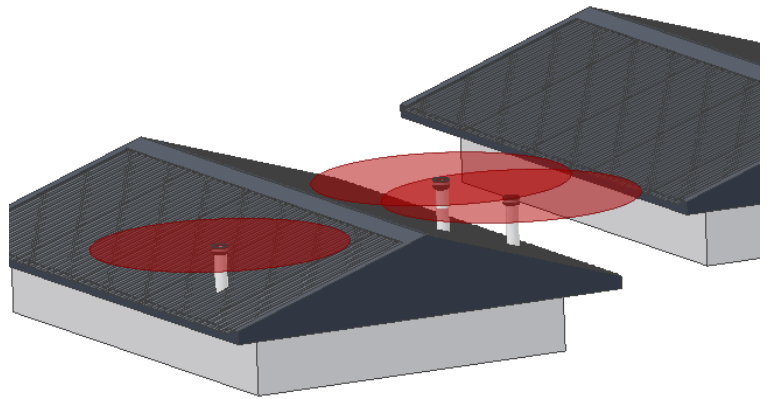

FRAME OUT AND TRIM OUT DETAILS FOR CHIMNEY CHASE

Option X – Singled Lined Flue System

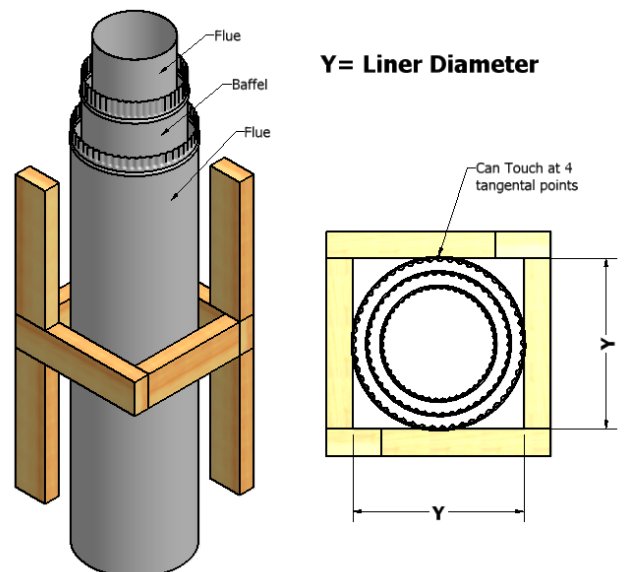
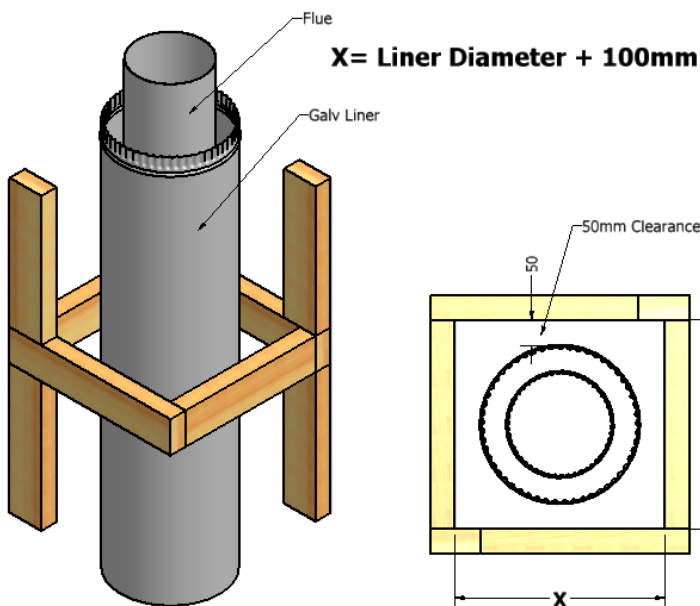

COMBUSTIBLE MANTLE CLEARANCES

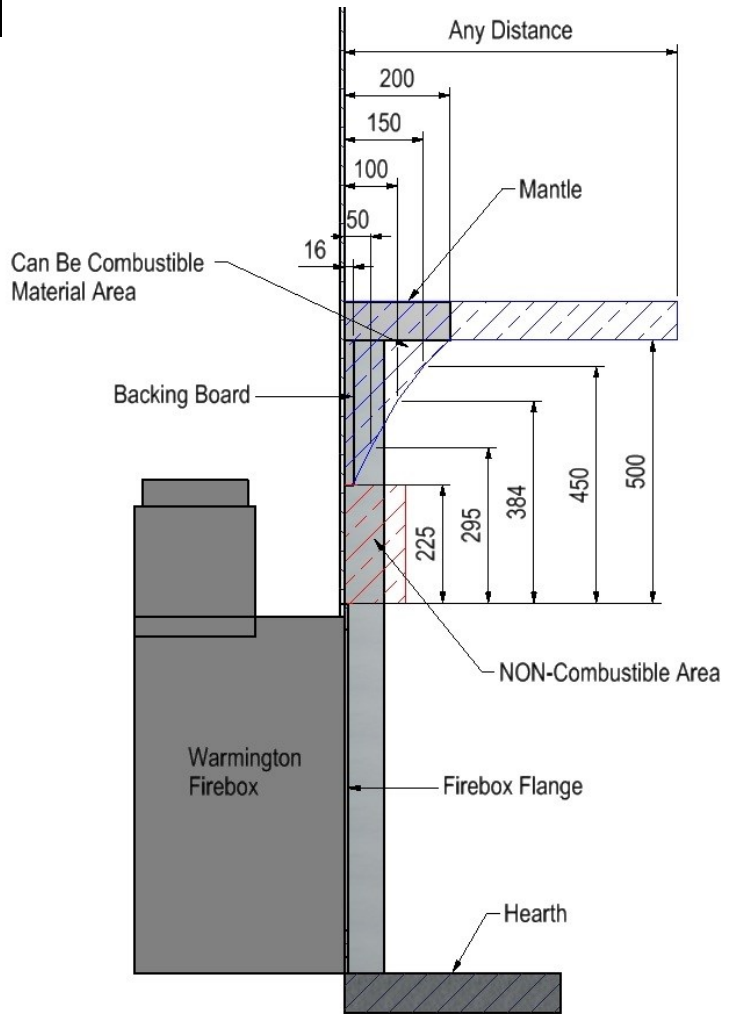
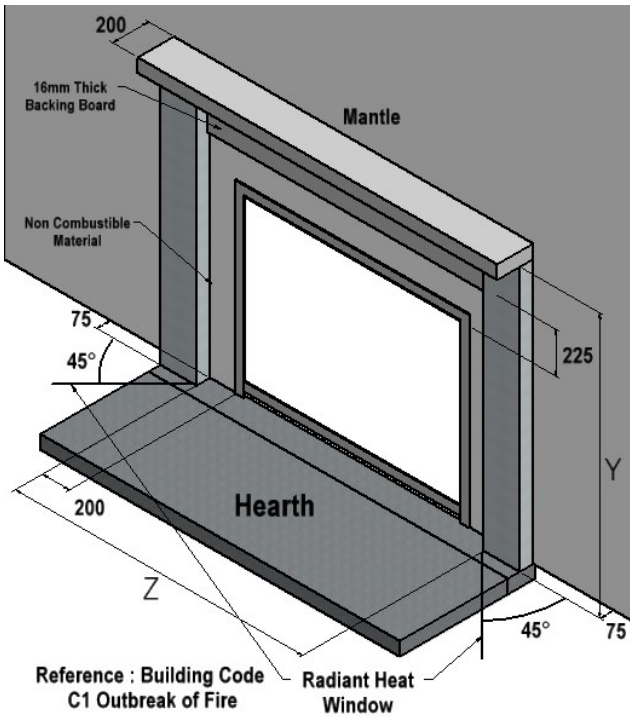

| Mantle Clearances | | |
|-------------------|------|------|
| Firebox | Y | Z |
| SI 780 | 1125 | 1230 |
| SI 780T | 1205 | 1230 |
| SI 900 | 1275 | 1350 |
| SI 1100 | 1325 | 1550 |

Note:
Twin Firebox mantle clearances, same as corresponding firebox sizes

HEARTH CLEARANCES

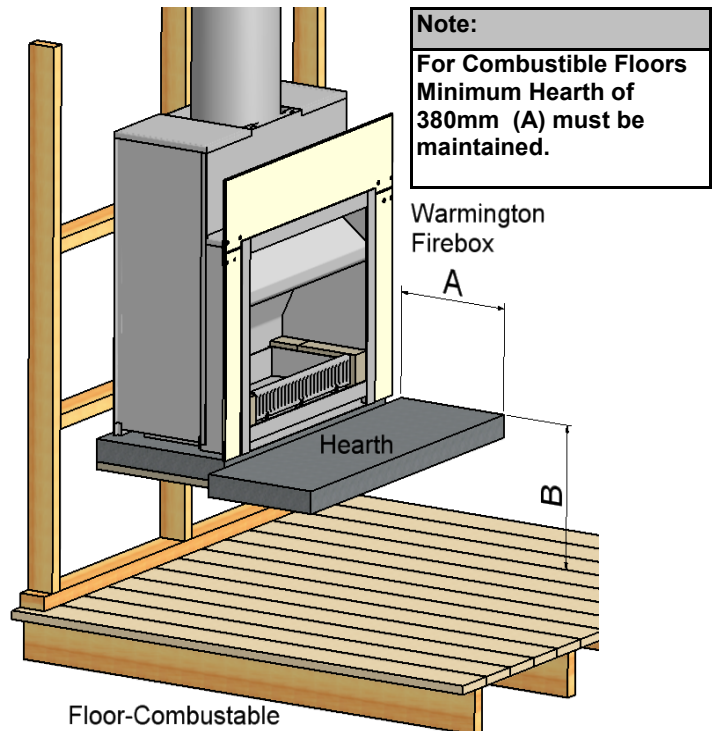
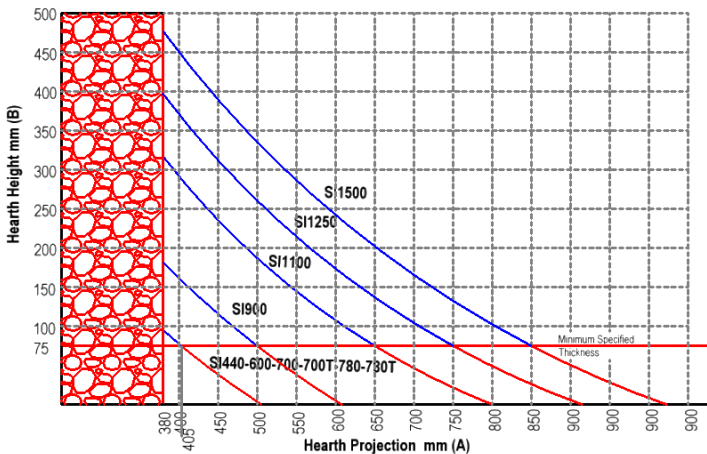

GENERAL NOTES : ASNZS 2918 : 2001**NOTES:**

- Fire Operation and Maintenance Instructions available from www.warmington.co.nz.
- Warranty - for full details on product warranties, contact your local Authorised Warmington Retailer.
- Correct installation, operation and maintenance must be maintained to comply with Warmington Warranty.
- The Appliance and Flue System must be Installed in accordance with ASNZS2918:2001 and the appropriate Building codes.
- The Flue system and fireplace is to be swept annually or more frequently if required.

WARNINGS:

- **WARNING; ANY MODIFICATION OF THE APPLIANCE THAT HAS NOT BEEN APPROVED IN WRITING BY THE TESTING AUTHORITY IS CONSIDERED AS BREACHING AS/NZS 4013.**
- **WARNING; DO NOT USE FLAMMABLE LIQUIDS OR AEROSOLS TO START OR REKINDLE THE FIRE.**
- **WARNING; DO NOT USE FLAMMABLE LIQUIDS OR AEROSOLS IN THE VICINITY OF THIS APPLIANCE WHEN IT IS OPERATING.**
- **WARNING; DO NOT STORE FUEL WITHIN HEATER INSTALLATION CLEARANCES.**
- **WARNING; WHEN OPERATION THIS APPLIANCE AS AN OPEN FIRE USE A SPARK SCREEN.**
- **CAUTION:** THIS APPLIANCE SHOULD BE MAINTAINED AND OPERATED AT ALL TIMES IN ACCORDANCE WITH THESE INSTRUCTIONS
- **CAUTION:** THE USE OF SOME TYPES OF PRESERVATIVE-TREATED WOOD AS A FUEL CAN BE HAZARDOUS.

| Model | Peak Output KW (Estimated) | Range KW (Estimated) |
|---------------------|--------------------------------------|--------------------------------|
| SI 780 Twin | 24 | 15-17 |
| SI 780T Twin | 26 | 17-19 |
| SI 900 Twin | 32 | 18-21 |
| SI 1100 Twin | 35 | 19-22 |

NOTE: For Operation Instruction download from the website
www.warmington.co.nz



Industries 1994 LTD
PO Box 5865, Botany 2163, Auckland www.warmington.co.nz