

Warmington Traditional Brick Open Fire

TF 1500 Firebox and Hebel Enclosure

NOTE: Requires Hebel Enclosure

Fire, Flue System to Comply with AS/NZS 2918:2001

Due to continued product improvement, Warmington Ind LTD reserves the right to change product specifications without prior notification.

Read all the Instructions carefully before commencing the Installation. Failure to follow these instructions may result in a fire hazard and void the warranty

For Specification See: www.warmington.co.nz

Copyright ©

*Note: Combustibles include timber, adhesives, plastics, etc - refer to AS/NZS 2918:2001

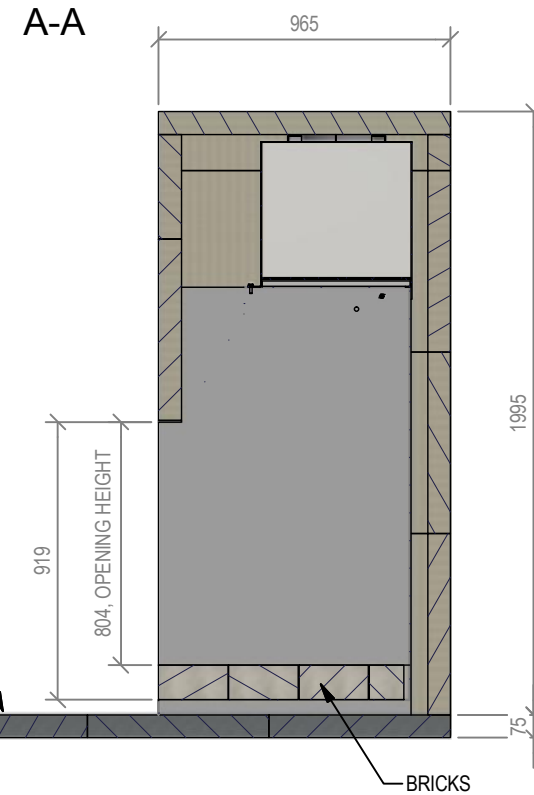

HEARTH:
CAN BE AS HIGH AS FIRE HEARTH
REBATED INTO FLOOR *
FLUSH WITH FLOOR *
STEPPED DOWN FROM FIRES HEARTH (BASE) *

Warmington Industries Ltd.	
PH: 09 273 9227 FAX: 09 273 9241 WEB: www.warmington.co.nz	
TITLE	TF 1500 FIREBOX AND HEBEL ENCLOSURE
DRAWN	EMLYN
DATE	31/05/17
SCALE	NOT TO SCALE
REVISION	02

B-B

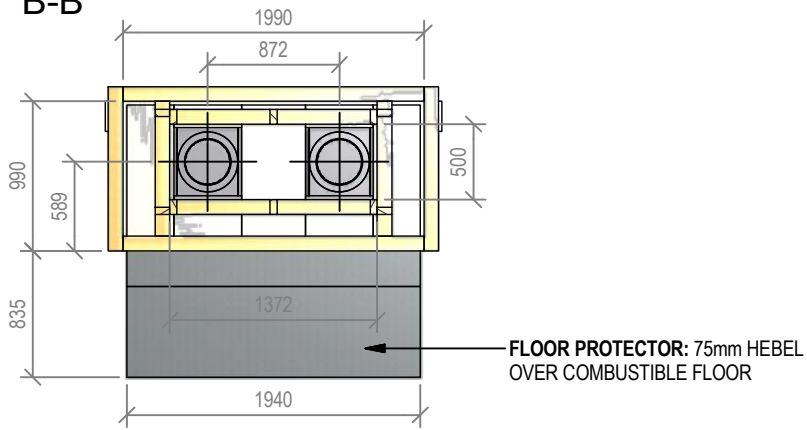

Warmington Traditional Brick Open Fire

TF 1500 Timber Framing

NOTE: Requires Hebel Enclosure

Fire, Flue System to Comply with AS/NZS 2918:2001

Due to continued product improvement, Warmington Ind LTD reserves the right to change product specifications without prior notification.

Read all the Instructions carefully before commencing the Installation. Failure to follow these instructions may result in a fire hazard and void the warranty

For Specification See: www.warmington.co.nz

Copyright ©

*Note: Combustibles include timber, adhesives, plastics, etc - refer to AS/NZS 2918:2001

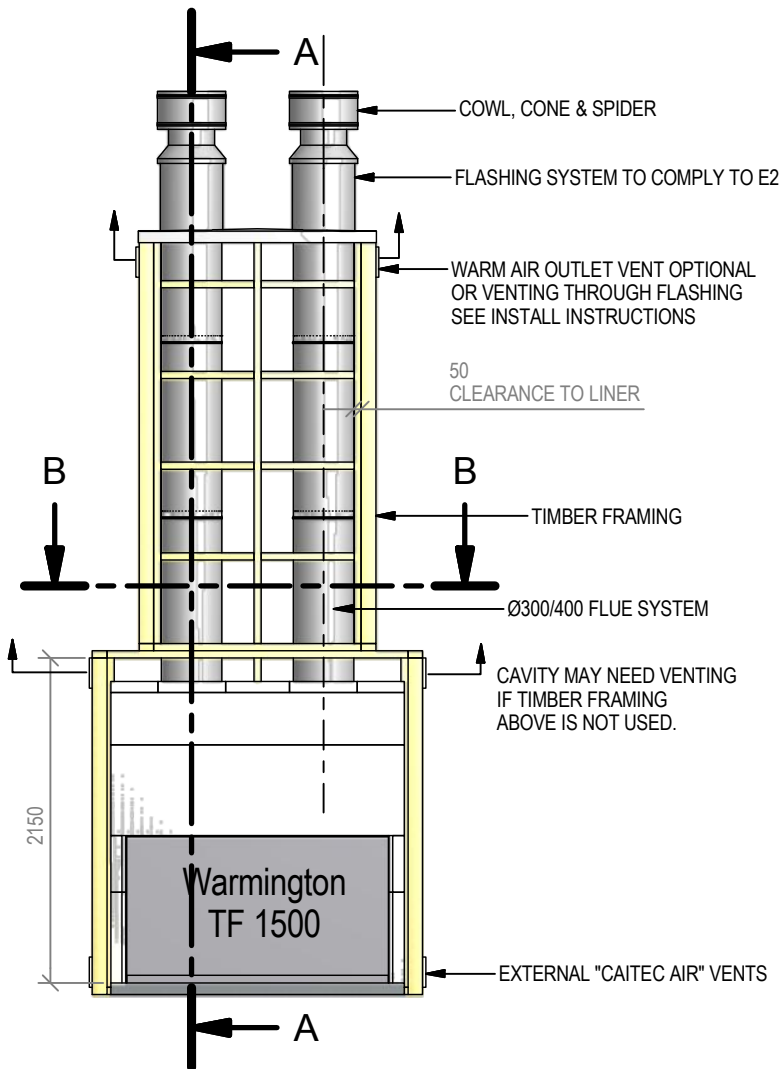

A-A

IMPORTANT NOTE:
WHERE AN INTERNAL WALL BOARD FINISH IS REQUIRED AROUND THE FIREPLACE, ENSURE ALLOWANCE IS MADE TO PLACE NON COMBUSTIBLE INTERNAL WALL LINING (e.g. PROMINA ETERPAN, SUPALUX) TO COVER THE EXTENT OF THE HEBEL BLOCK SURROUND

DIRECTLY TOUCHING THE FIREBOX WITH ANY BOARD OR PLASTER MAY CAUSE CRACKING FROM HEAT EXPANSION
ALLOW 3mm MINIMUM SPACE AWAY FROM THE FIREBOX

NO COMBUSTABLE MATERIAL TO BE USED IN OR ON THIS AREA

ALLOW FINISHING ON FLOOR PROTECTOR SEE INSTALL DETAILS

NOTE:
WARMINGTON CAITEC AIR IS REQUIRED SEE SPECIFIC INSTALL INSTRUCTION

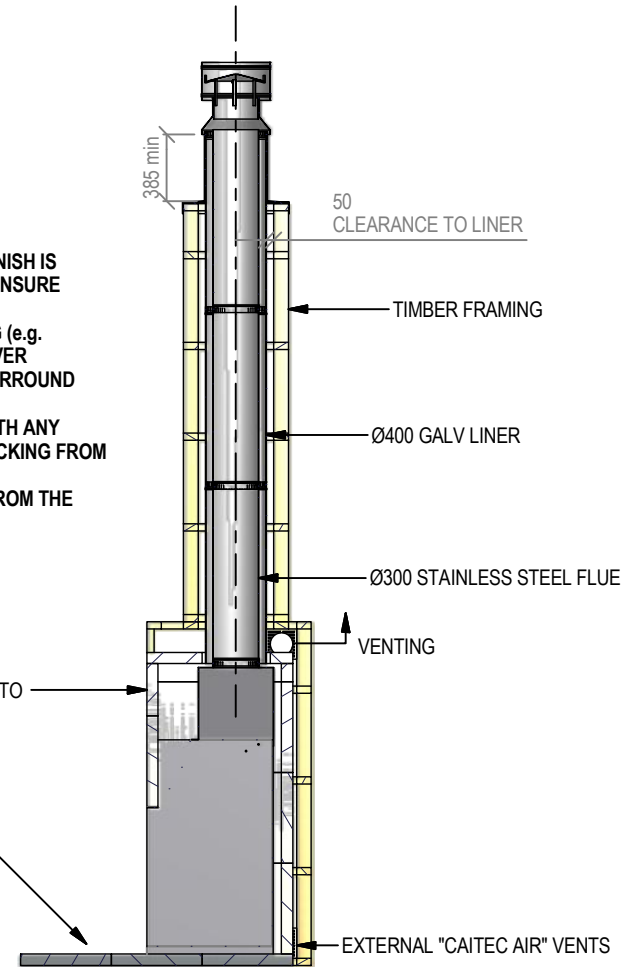

Warmington Industries Ltd.			
PH: 09 273 9227 FAX: 09 273 9241 WEB: www.warmington.co.nz			
TITLE	TF 1500 TIMBER FRAMING	DATE	20/05/11
DRAWN	ROBERT	REVISION	01
SCALE	NOT TO SCALE		

B-B

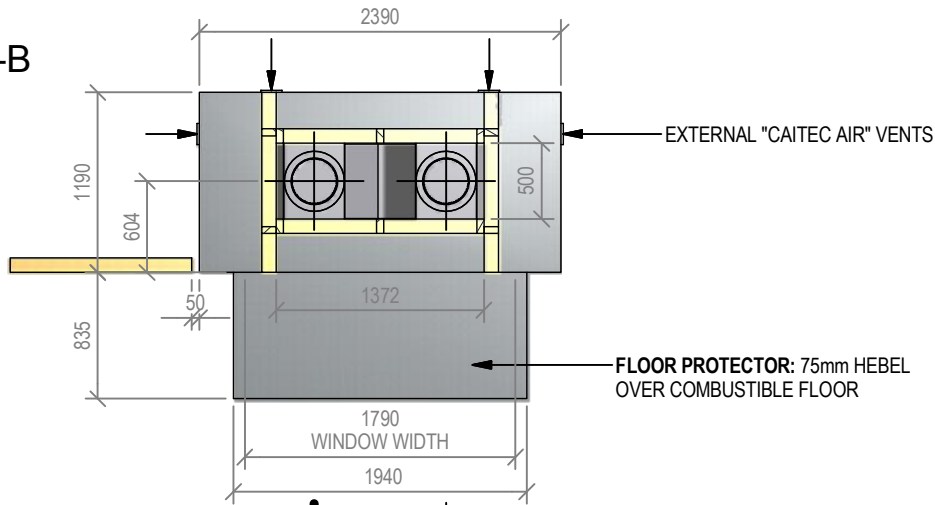

Warmington Traditional Brick Open Fire

TF 1500 Block Enclosure - No Hebel

NOTE: Requires Hebel Enclosure

Fire, Flue System to Comply with ASNZS 2918:2001

Due to continued product improvement, Warmington Ind LTD reserves the right to change product specifications without prior notification.

Read all the Instructions carefully before commencing the Installation. Failure to follow these instructions may result in a fire hazard and void the warranty

For Specification See: www.warmington.co.nz

Copyright ©

*Note: Combustibles include timber, adhesives, plastics, etc - refer to ASNZS 2918:2001

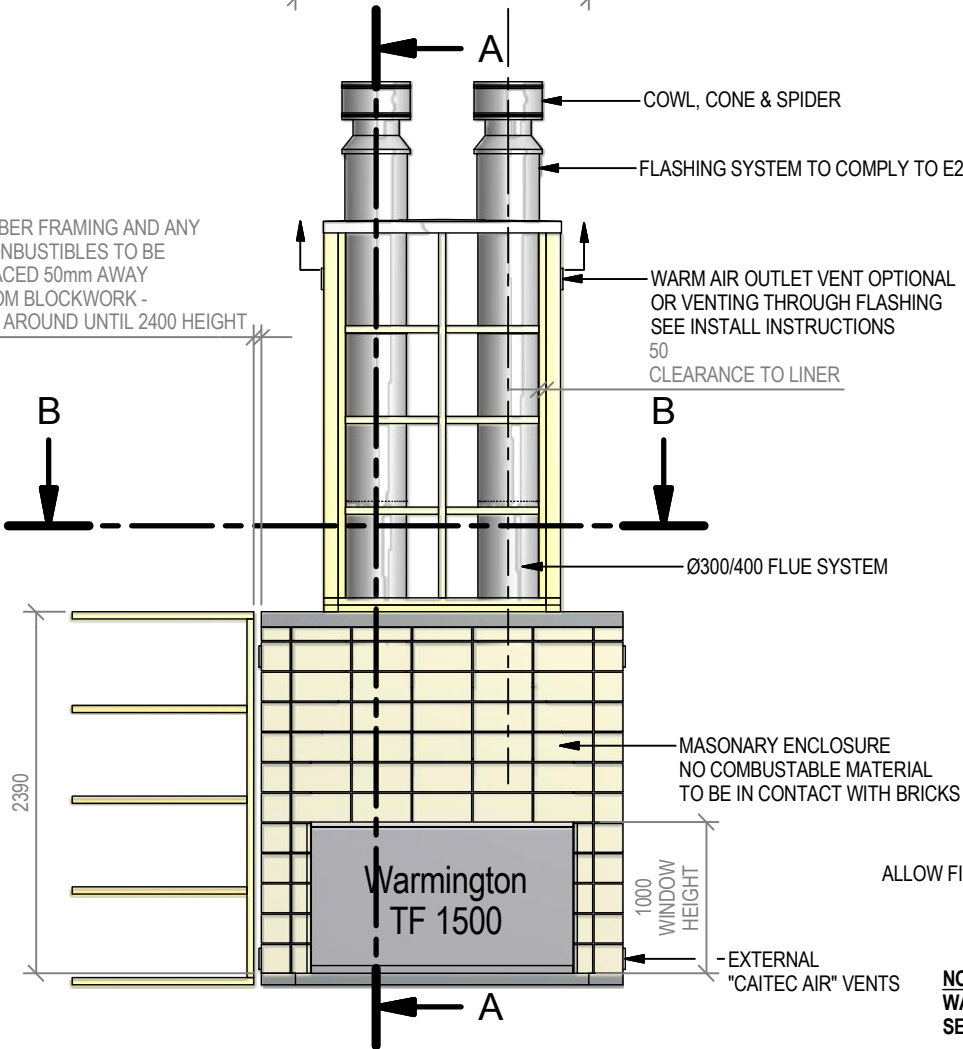

IMPORTANT NOTE:

WHERE AN INTERNAL WALL BOARD FINISH IS REQUIRED AROUND THE FIREPLACE, ENSURE ALLOWANCE IS MADE TO PLACE NON COMBUSTIBLE INTERNAL WALL LINING (e.g. PROMINA ETERPAN, SUPALUX) TO COVER THE EXTENT OF THE HEBEL BLOCK SURROUND

DIRECTLY TOUCHING THE FIREBOX WITH ANY BOARD OR PLASTER MAY CAUSE CRACKING FROM HEAT EXPANSION
ALLOW 3mm MINIMUM SPACE AWAY FROM THE FIREBOX

A-A

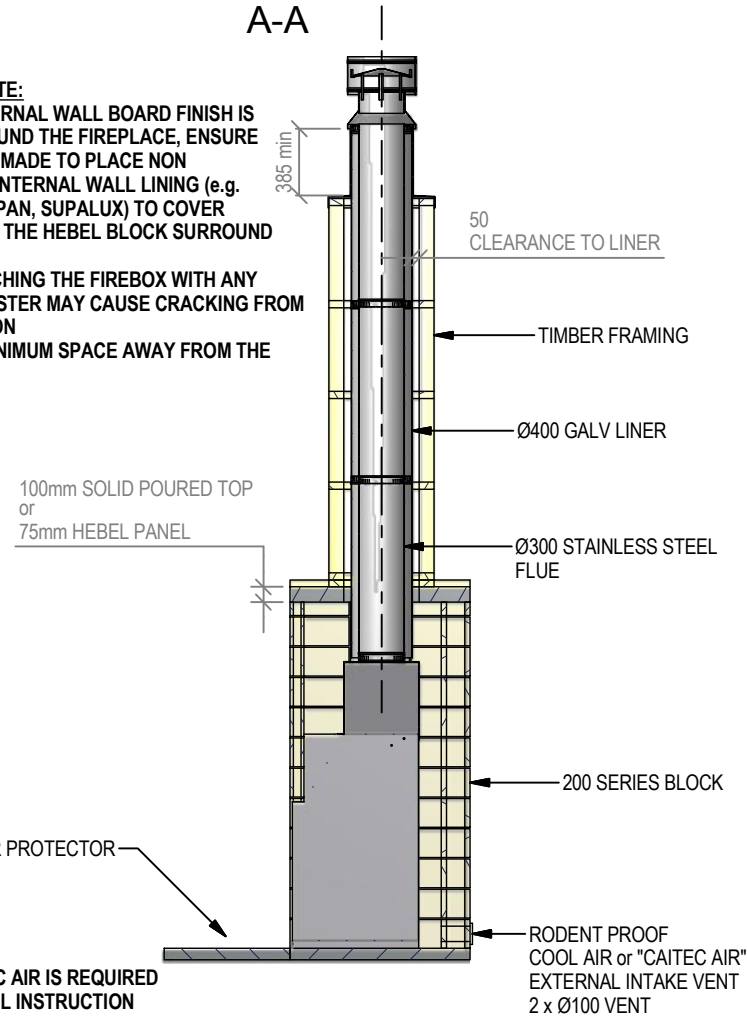

NOTE:
WARMINGTON CAITEC AIR IS REQUIRED
SEE SPECIFIC INSTALL INSTRUCTION

Warmington Industries Ltd.			
PH: 09 273 9227 FAX: 09 273 9241 WEB: www.warmington.co.nz			
TITLE	TF 1500 BLOCK ENCLOSURE NO HEBEL	DATE	23/05/11
DRAWN	ROBERT	SCALE	NOT TO SCALE
SCALE	NOT TO SCALE	REVISION	01

B-B

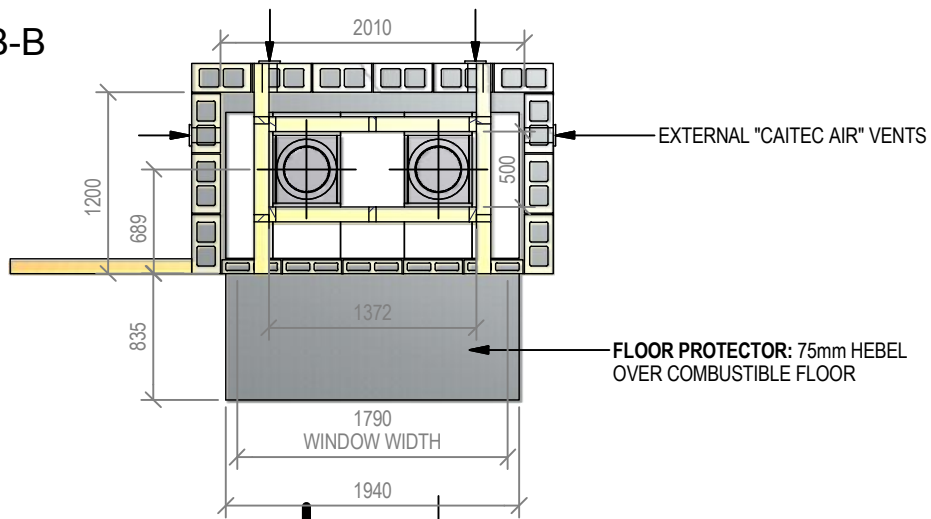

Warmington Traditional Brick Open Fire

TF 1500 Block Enclosure With Hebel

NOTE: Requires Hebel Enclosure

Fire, Flue System to Comply with ASNZS 2918:2001

Due to continued product improvement, Warmington Ind LTD reserves the right to change product specifications without prior notification.

Read all the Instructions carefully before commencing the Installation. Failure to follow these

instructions may result in a fire hazard and void the warranty

For Specification See: www.warmington.co.nz

Copyright ©

*Note: Combustibles include timber, adhesives, plastics, etc - refer to ASNZS 2918:2001

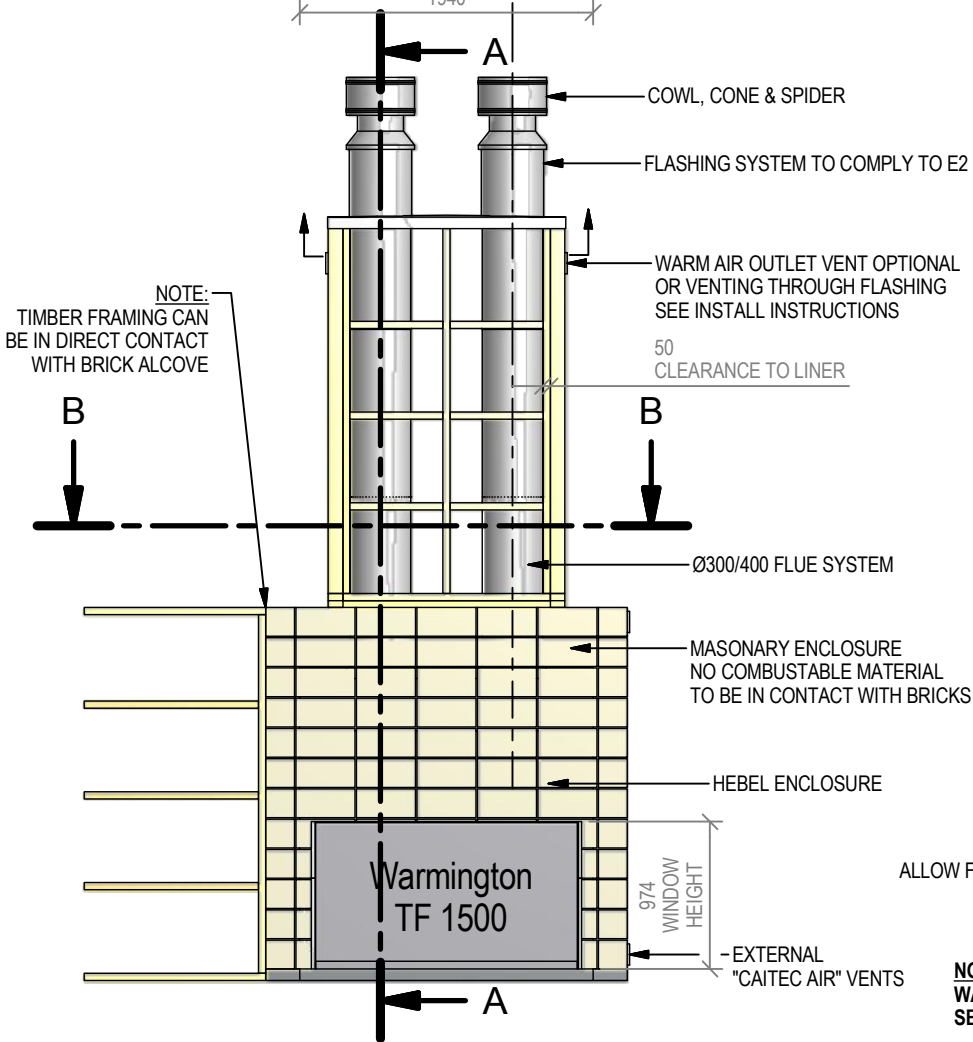

IMPORTANT NOTE:
WHERE AN INTERNAL WALL BOARD FINISH IS REQUIRED AROUND THE FIREPLACE, ENSURE ALLOWANCE IS MADE TO PLACE NON COMBUSTIBLE INTERNAL WALL LINING (e.g. PROMINA ETERPAN, SUPALUX) TO COVER THE EXTENT OF THE HEBEL BLOCK SURROUND

DIRECTLY TOUCHING THE FIREBOX WITH ANY BOARD OR PLASTER MAY CAUSE CRACKING FROM HEAT EXPANSION
ALLOW 3mm MINIMUM SPACE AWAY FROM THE FIREBOX

ALLOW FINISHING ON FLOOR PROTECTOR

NOTE:
WARMINGTON CAITEC AIR IS REQUIRED
SEE SPECIFIC INSTALL INSTRUCTION

A-A

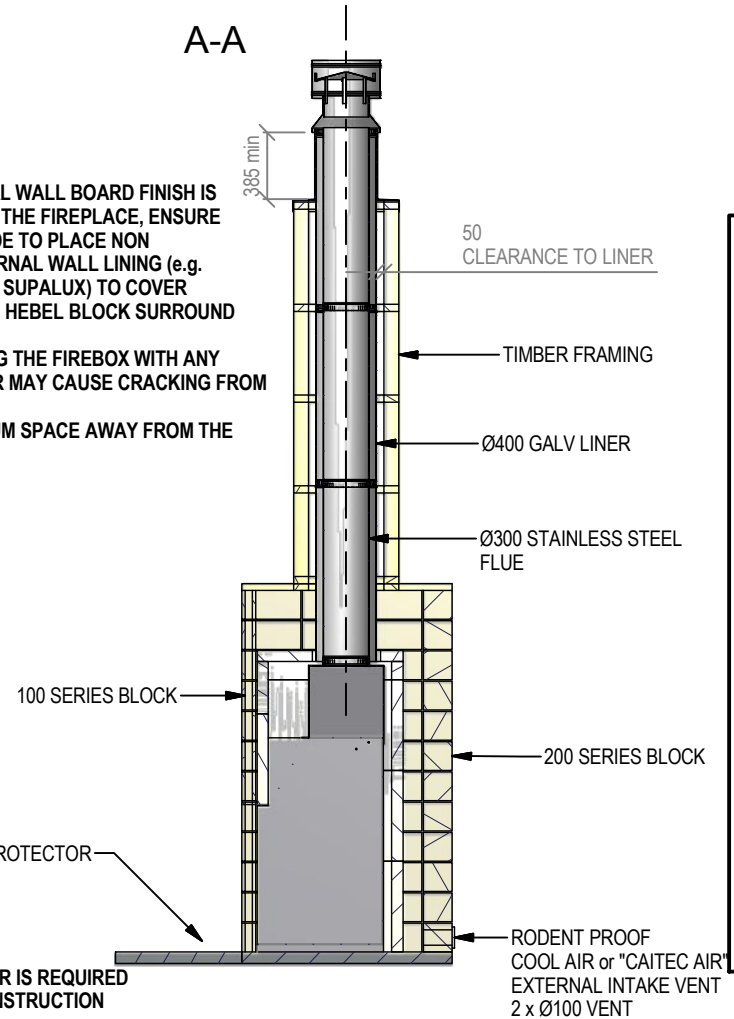

Warmington Industries Ltd.			
PH: 09 273 9227 FAX: 09 273 9241 WEB: www.warmington.co.nz			
TITLE	TF 1500 BLOCK ENCLOSURE WITH HEBEL	DATE	23/05/11
DRAWN	ROBERT	SCALE	NOT TO SCALE
REVISION		REVISION	01