

Solid Fuel Flashing & Cowl Systems

Note:
Flashing Spigot Height is determined by the Insulation that is fitted under the Flashing ... See Details at bottom of page.

Note:
ALL Material above Flashing to be made from NON-COMBUSTIBLE Material

Flue Ø	A	B
150	300	326
200	386	376
250	435	426
275	460	426
300	450	476
325	511	496
350	536	496
375	561	496
400	586	496
425	611	496
450	636	496
500	636	456

Minimum Clearance

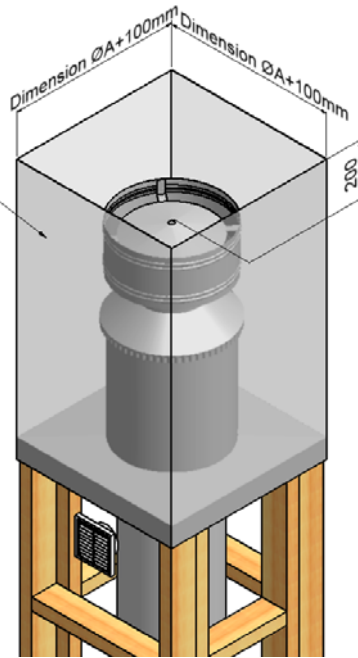

General Chimney Chase Flashing Lay Out

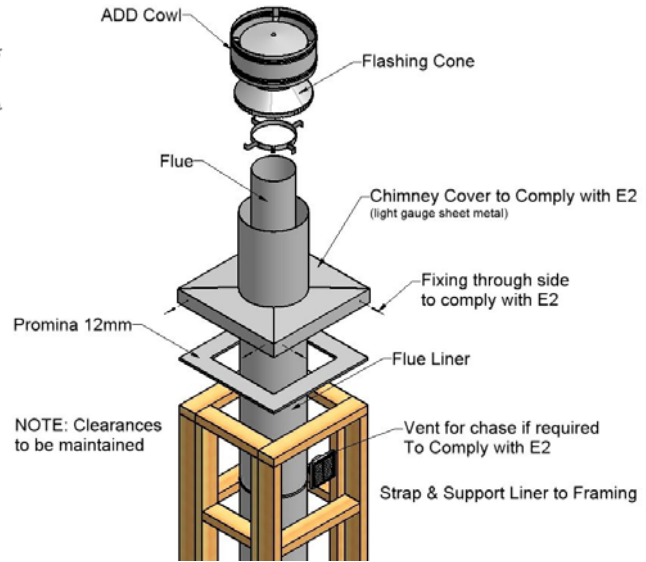

Disclaimer
It is NOT Recommended to Cover or Impede the Cowl System by Constructing details Over or Around Cowl System this may Reduce performance of Fire & may cause Fire to smoke by Restricting Air around Cowl . Warmington Except NO Responsibility for Structures & their effect on the Fire . Only carried out at Clients Request .

VENTING THROUGH CHIMNEY CHASE

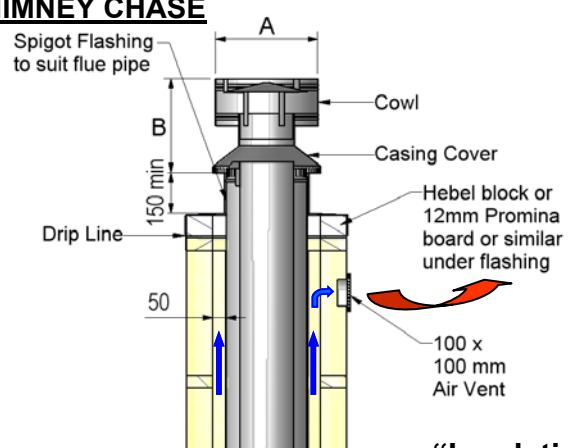
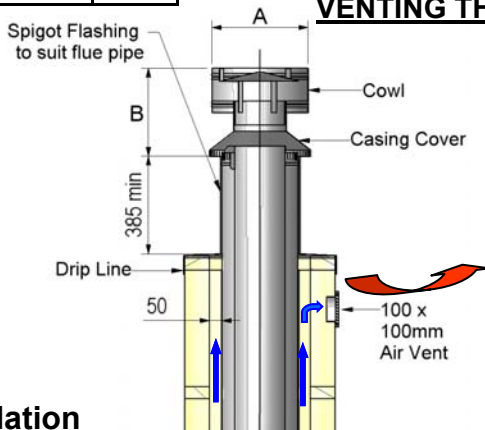

“No Insulation under Flash-”

VENTING THROUGH FLASHING

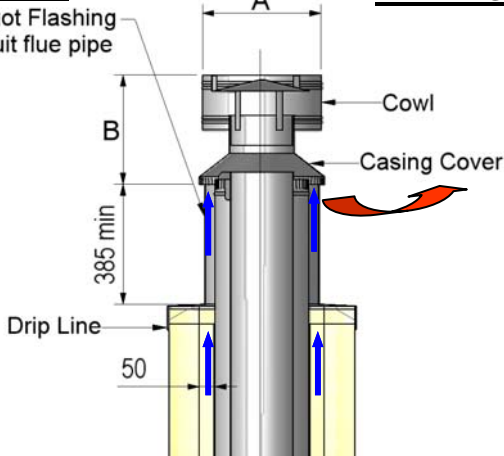

“Insulation under Flashing”

