

Warmington Outdoor Wood Fire

SN 1250 Pizzeria Firebox

NOTE: Requires Hebel Enclosure

Fire, Flue System to Comply with ASNZS 2918:2001

Due to continued product improvement, Warmington Ind LTD reserves the right to change product specifications without prior notification.

Read all the Instructions carefully before commencing the Installation. Failure to follow these instructions may result in a fire hazard and void the warranty

For Specification See: www.warmington.co.nz

Copyright ©

NOTE: Engineering calculations may be required

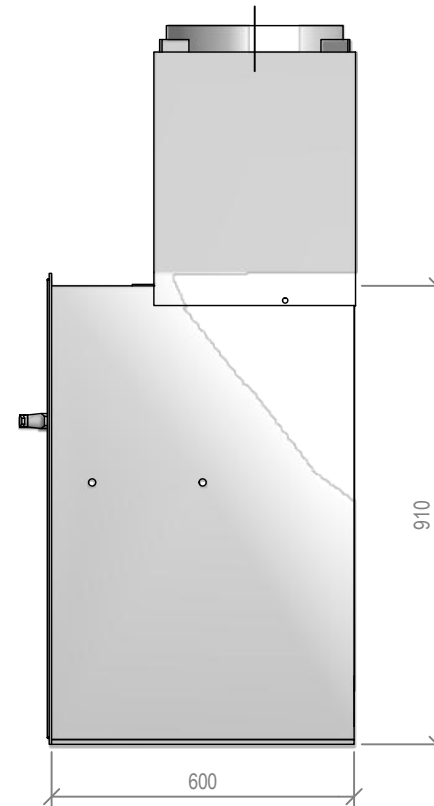
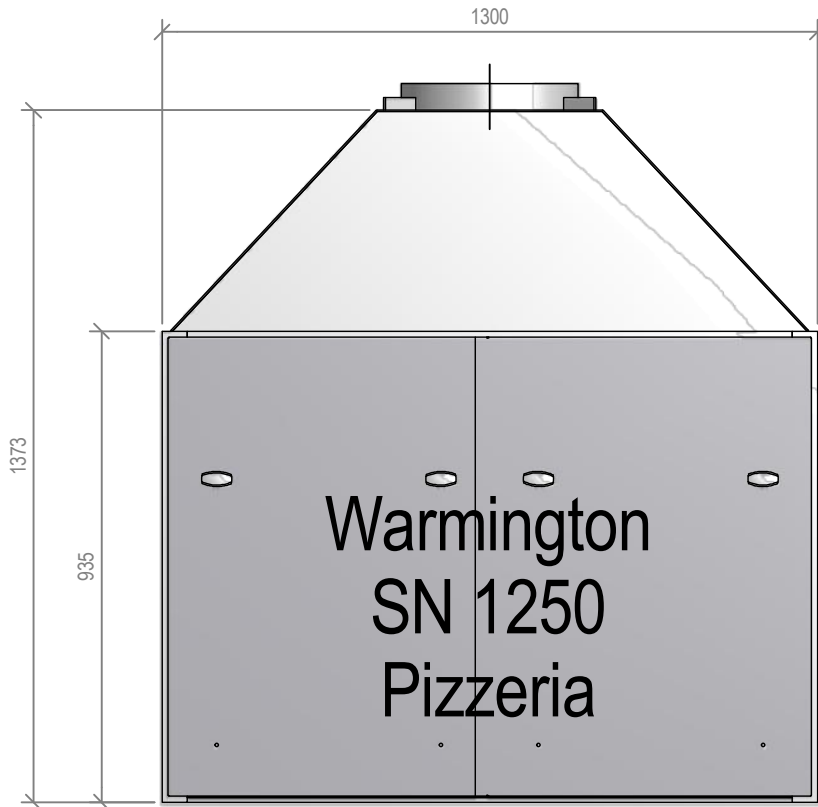
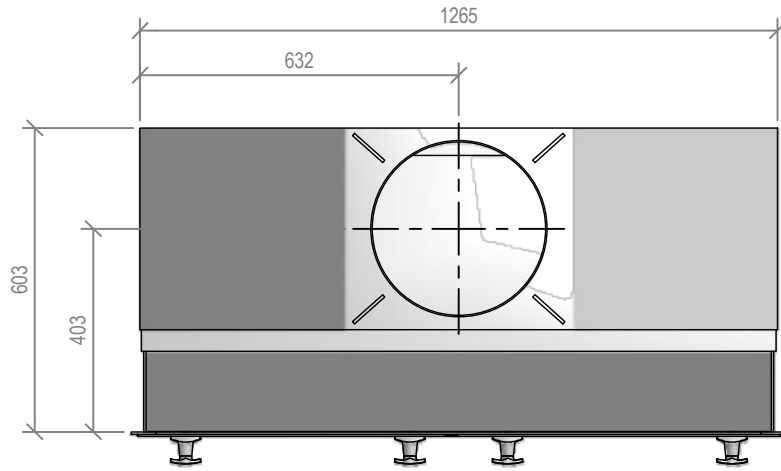

Warmington Industries Ltd.			
PH: 09 273 9227 FAX: 09 273 9241 WEB: www.warmington.co.nz			
TITLE	SN 1250 Pizzeria FIREBOX		
DRAWN	BEN	DATE	30/08/17
SCALE	NOT TO SCALE	REVISION	02

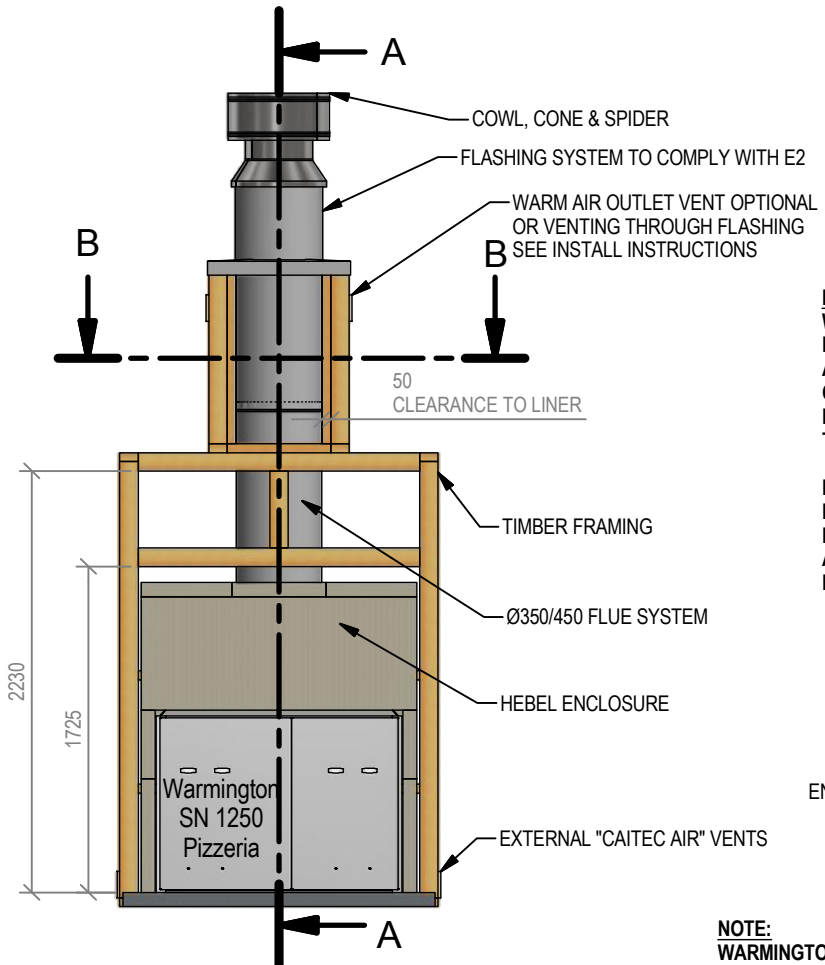
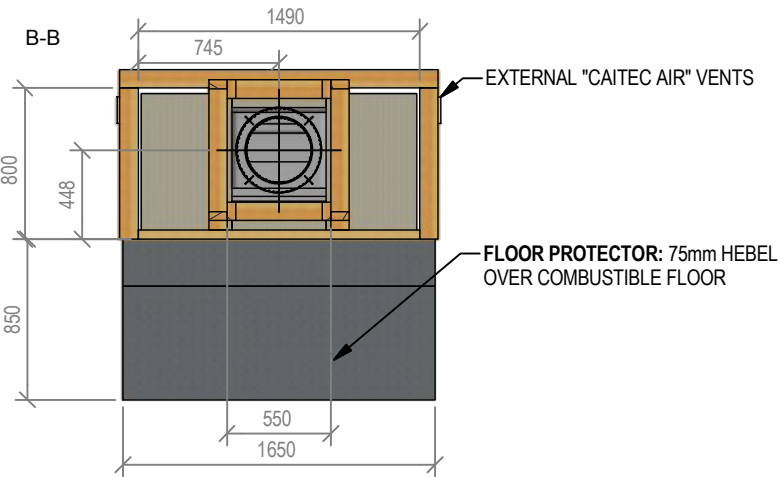

Warmington Outdoor Wood Fire

SN 1250 Pizzeria Timber Framing

NOTE: Requires Hebel Enclosure
 Fire, Flue System to Comply with ASNZS 2918:2001
Due to continued product improvement, Warmington Ind LTD reserves the right to change product specifications without prior notification.
 Read all the Instructions carefully before commencing the Installation. Failure to follow these instructions may result in a fire hazard and void the warranty
 For Specification See: www.warmington.co.nz
 Copyright ©

NOTE: Engineering calculations may be required

IMPORTANT NOTE:
 WHERE AN INTERNAL WALL BOARD FINISH IS REQUIRED AROUND THE FIREPLACE, ENSURE ALLOWANCE IS MADE TO PLACE NON COMBUSTIBLE INTERNAL WALL LINING (e.g. PROMINA ETERPAN, SUPALUX) TO COVER THE EXTENT OF THE HEBEL BLOCK SURROUND

DIRECTLY TOUCHING THE FIREBOX WITH ANY BOARD OR PLASTER MAY CAUSE CRACKING FROM HEAT EXPANSION
 ALLOW 3mm MINIMUM SPACE AWAY FROM THE FIREBOX

SECURE FIRE TO BASE WITH 2 X M6 DYNA BOLTS
 SEE INSTRUCTIONS

ENSURE THE LOWER AIR INTAKE IS NOT OBSTRUCTED

ALLOW FINISHING ON FLOOR PROTECTOR

NOTE:
 WARMINGTON CAITEC AIR IS REQUIRED
 SEE SPECIFIC INSTALL INSTRUCTION

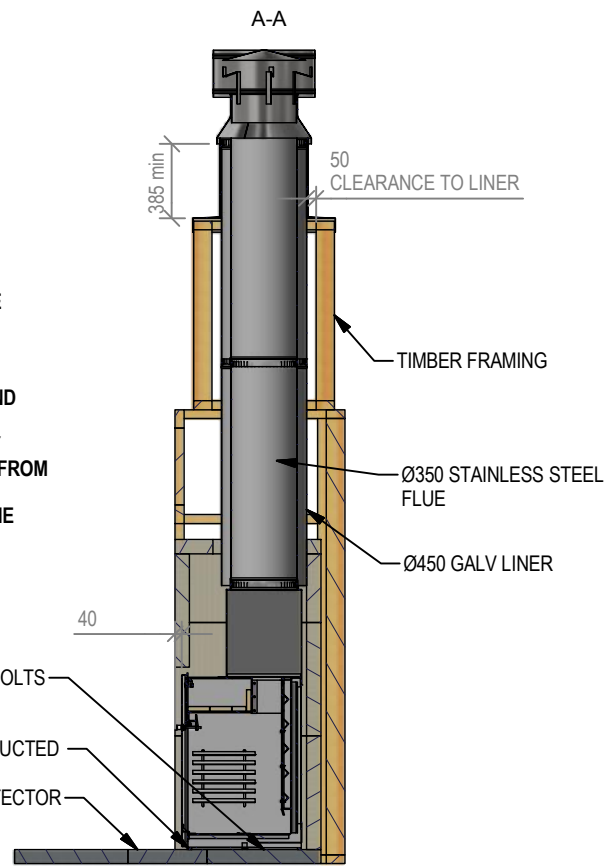

Warmington Industries Ltd.			
PH: 09 273 9227 FAX: 09 273 9241 WEB: www.warmington.co.nz			
TITLE	SN 1250 Pizzeria TIMBER FRAMING	DATE	30/08/17
DRAWN	BEN	REVISION	02
SCALE	NOT TO SCALE		

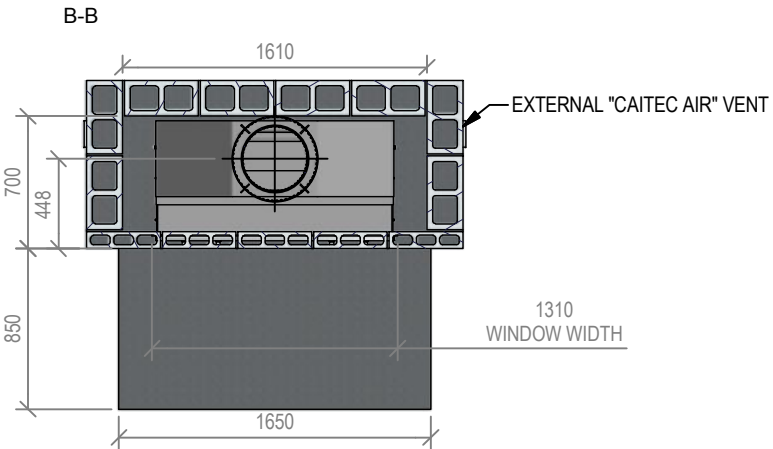

Warmington Outdoor Wood Fire

SN 1250 Pizzeria Block Enclosure

Fire, Flue System to Comply with ASNZS 2918:2001

Due to continued product improvement, Warmington Ind LTD reserves the right to change product specifications without prior notification.

Read all the Instructions carefully before commencing the Installation. Failure to follow these instructions may result in a fire hazard and void the warranty

For Specification See: www.warmington.co.nz

Copyright ©

NOTE: Engineering calculations may be required

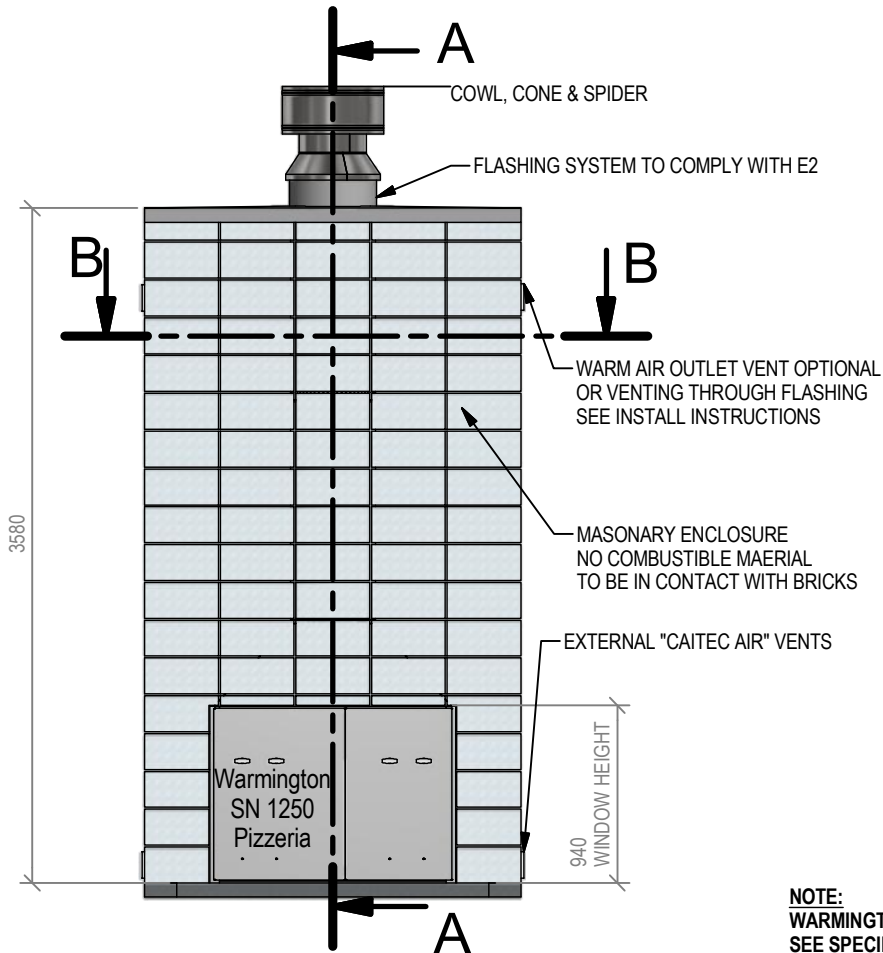

IMPORTANT NOTE:
WHERE AN INTERNAL WALL BOARD FINISH IS REQUIRED AROUND THE FIREPLACE, ENSURE ALLOWANCE IS MADE TO PLACE NON COMBUSTIBLE INTERNAL WALL LINING (e.g. PROMINA ETERPAN, SUPALUX) TO COVER THE EXTENT OF THE HEBEL BLOCK SURROUND

DIRECTLY TOUCHING THE FIREBOX WITH ANY BOARD OR PLASTER MAY CAUSE CRACKING FROM HEAT EXPANSION
ALLOW 3mm MINIMUM SPACE AWAY FROM THE FIREBOX

NOTE:
WARMINGTON CAITEC AIR IS REQUIRED
SEE SPECIFIC INSTALL INSTRUCTION

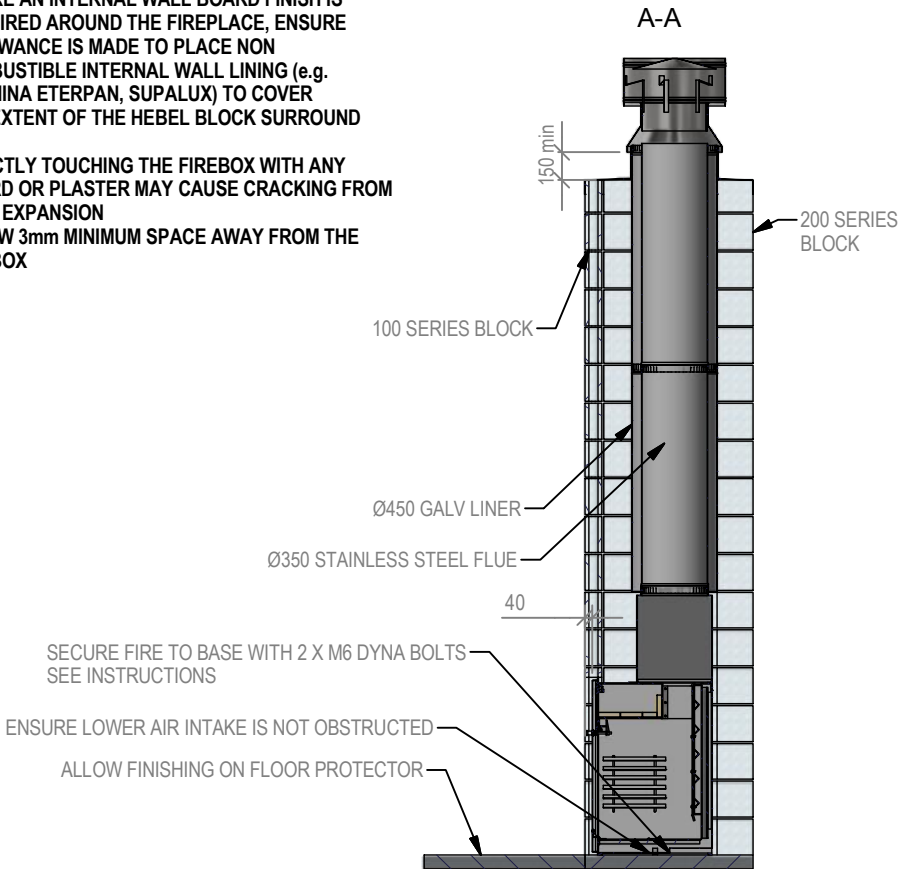

Warmington Industries Ltd.			
PH: 09 273 9227 FAX: 09 273 9241 WEB: www.warmington.co.nz			
TITLE	SN 1250 Pizzeria BLOCK ENCLOSURE	DATE	30/08/17
DRAWN	BEN	REVISION	02
SCALE	NOT TO SCALE		