

# Warmington Open Wood Fire

## SN 1100 Firebox

NOTE: Requires Hebel Enclosure

Fire, Flue System to Comply with AS/NZS 2918:2001

**Due to continued product improvement, Warmington Ind LTD reserves the right to change product specifications without prior notification.**

Read all the Instructions carefully before commencing the Installation. Failure to follow these instructions may result in a fire hazard and void the warranty

For Specification See: [www.warmington.co.nz](http://www.warmington.co.nz)

Copyright ©

NOTE: Engineering calculations may be required

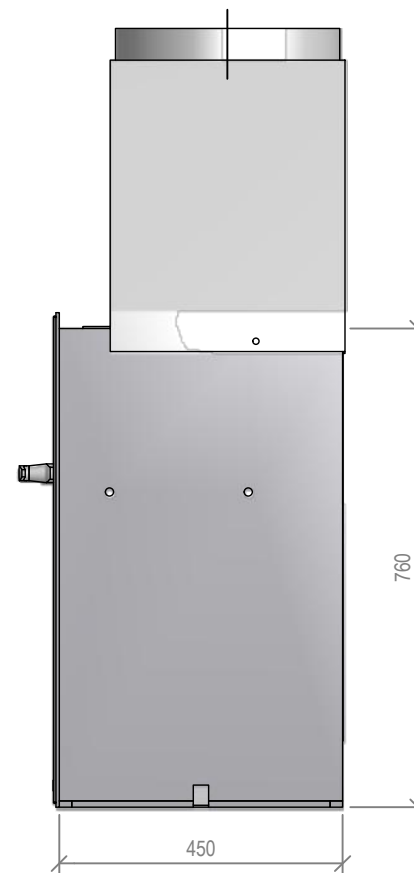
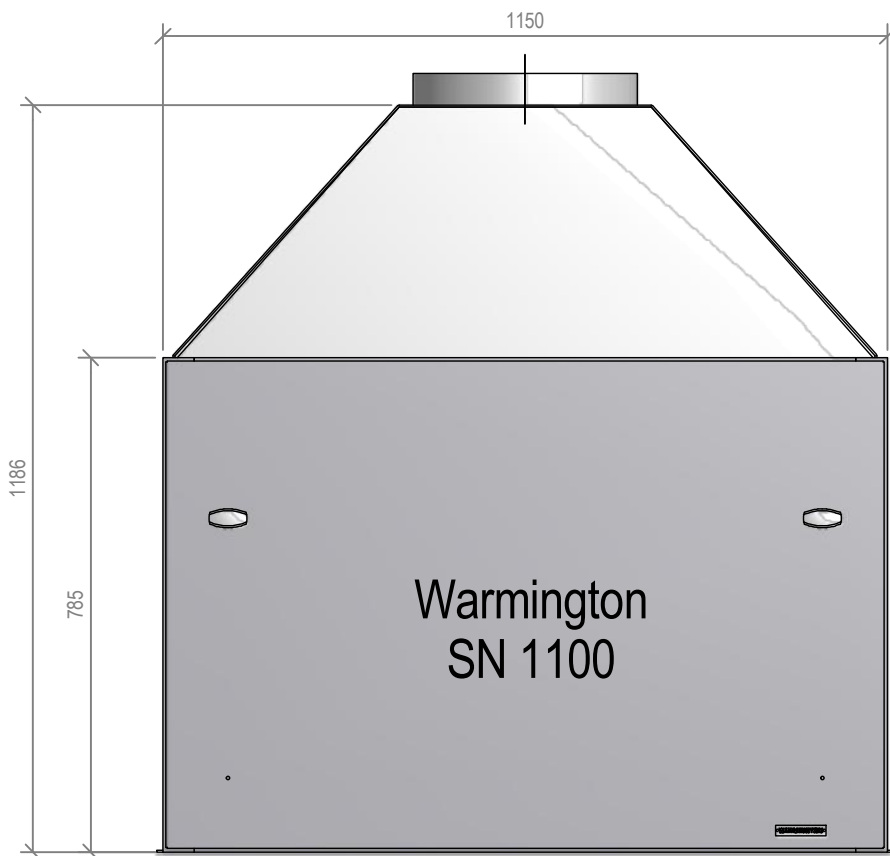

<b>Warmington Industries Ltd.</b>			
PH: 09 273 9227 FAX: 09 273 9241 WEB: <a href="http://www.warmington.co.nz">www.warmington.co.nz</a>			
TITLE	SN 1100 FIREBOX		
DRAWN	ROBERT	DATE	27/05/11
SCALE	NOT TO SCALE	REVISION	01

B-B

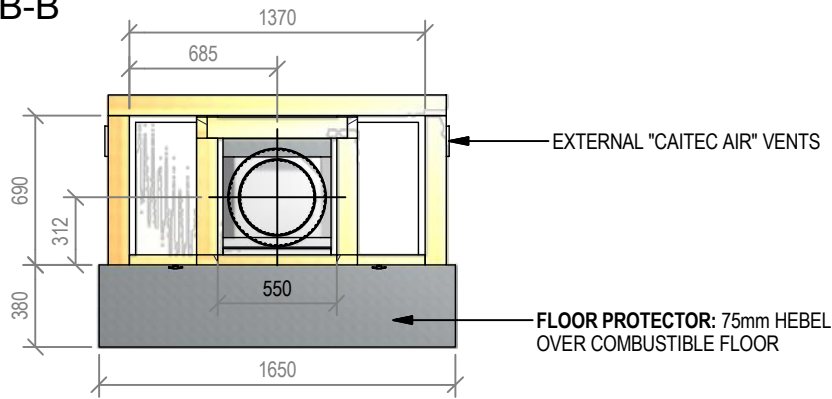

## Warmington Open Wood Fire

SN 1100 Timber Framing

NOTE: Requires Hebel Enclosure

Fire, Flue System to Comply with ASNZS 2918:2001

**Due to continued product improvement, Warmington Ind LTD reserves the right to change product specifications without prior notification.**

Read all the instructions carefully before commencing the Installation. Failure to follow these

instructions may result in a fire hazard and void the warranty

For Specification See: [www.warmington.co.nz](http://www.warmington.co.nz)

Copyright ©

NOTE: Engineering calculations may be required

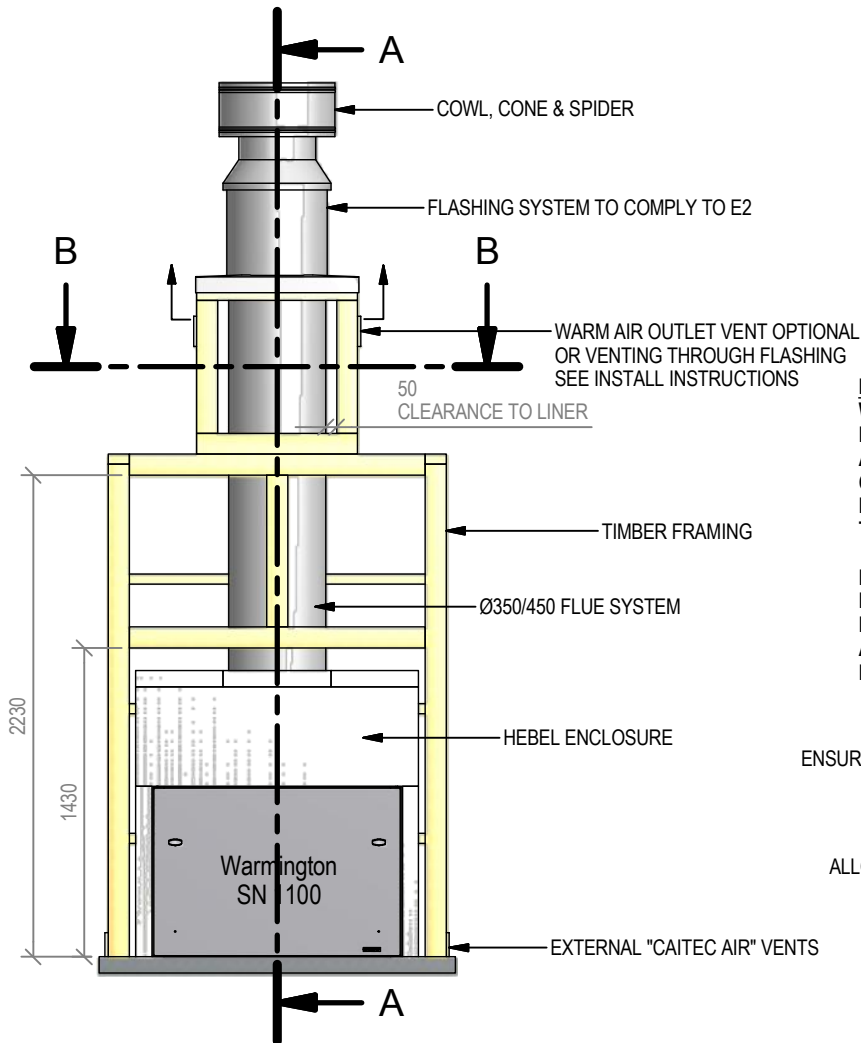

A-A

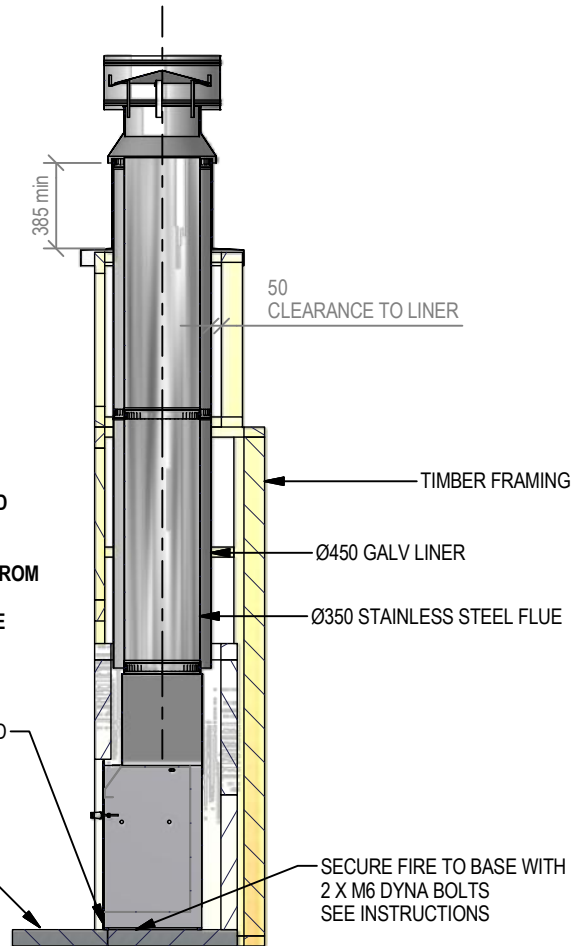

**IMPORTANT NOTE:**

WHERE AN INTERNAL WALL BOARD FINISH IS REQUIRED AROUND THE FIREPLACE, ENSURE ALLOWANCE IS MADE TO PLACE NON COMBUSTIBLE INTERNAL WALL LINING (e.g. PROMINA ETERPAN, SUPALUX) TO COVER THE EXTENT OF THE HEBEL BLOCK SURROUND

DIRECTLY TOUCHING THE FIREBOX WITH ANY BOARD OR PLASTER MAY CAUSE CRACKING FROM HEAT EXPANSION  
ALLOW 3mm MINIMUM SPACE AWAY FROM THE FIREBOX

ENSURE THE LOWER AIR INTAKE IS NOT OBSTRUCTED

ALLOW FINISHING ON FLOOR PROTECTOR

**NOTE:**

WARMINGTON CAITEC AIR IS REQUIRED  
SEE SPECIFIC INSTALL INSTRUCTION

<b>Warmington Industries Ltd.</b>			
PH: 09 273 9227 FAX: 09 273 9241 WEB: <a href="http://www.warmington.co.nz">www.warmington.co.nz</a>			
TITLE	SN 1100 TIMBER FRAMING	DATE	27/05/11
DRAWN	ROBERT	SCALE	NOT TO SCALE
		REVISION	01

G-G ( 1/35 )

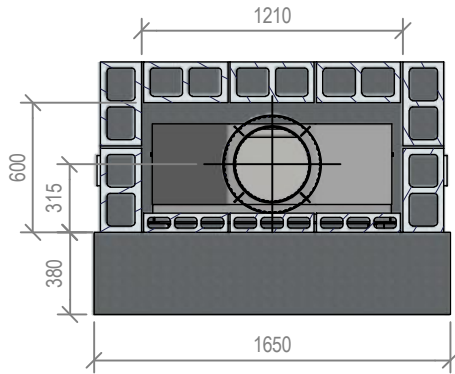

## Warmington Open Wood Fire

SN 1100 Block Enclosure

Fire, Flue System to Comply with ASNZS 2918:2001

**Due to continued product improvement, Warmington Ind LTD reserves the right to change product specifications without prior notification.**

Read all the Instructions carefully before commencing the Installation. Failure to follow these

instructions may result in a fire hazard and void the warranty

For Specification See: [www.warmington.co.nz](http://www.warmington.co.nz)

Copyright ©

NOTE: Engineering calculations may be required

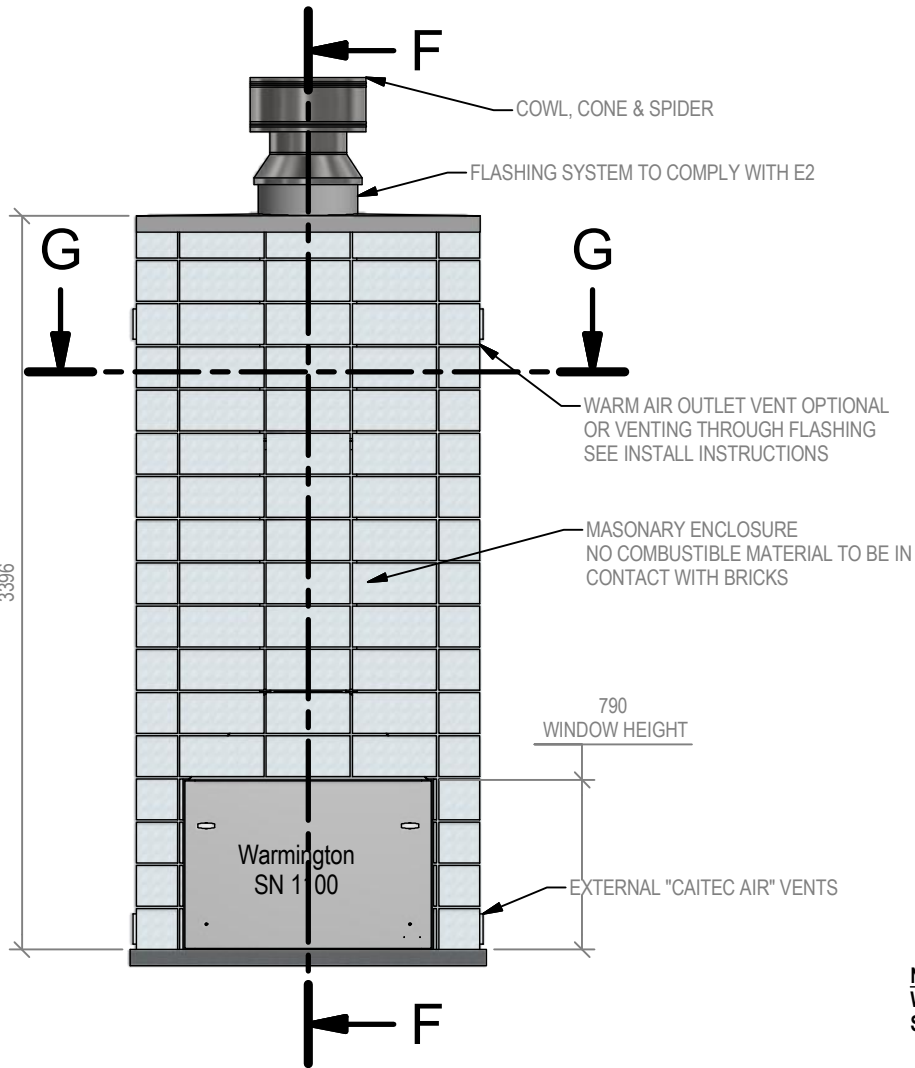

F-F ( 1/35 )

**IMPORTANT NOTE:**  
 WHERE AN INTERNAL WALL BOARD FINISH IS REQUIRED AROUND THE FIREPLACE, ENSURE ALLOWANCE IS MADE TO PLACE NON COMBUSTIBLE INTERNAL WALL LINING (e.g. PROMINA ETERPAN, SUPALUX) TO COVER THE EXTENT OF THE HEBEL BLOCK SURROUND

DIRECTLY TOUCHING THE FIREBOX WITH ANY BOARD OR PLASTER MAY CAUSE CRACKING FROM HEAT EXPANSION  
 ALLOW 3mm MINIMUM SPACE AWAY FROM THE FIREBOX

**NOTE:**  
 WARMINGTON CAITEC AIR IS REQUIRED  
 SEE SPECIFIC INSTALL INSTRUCTION

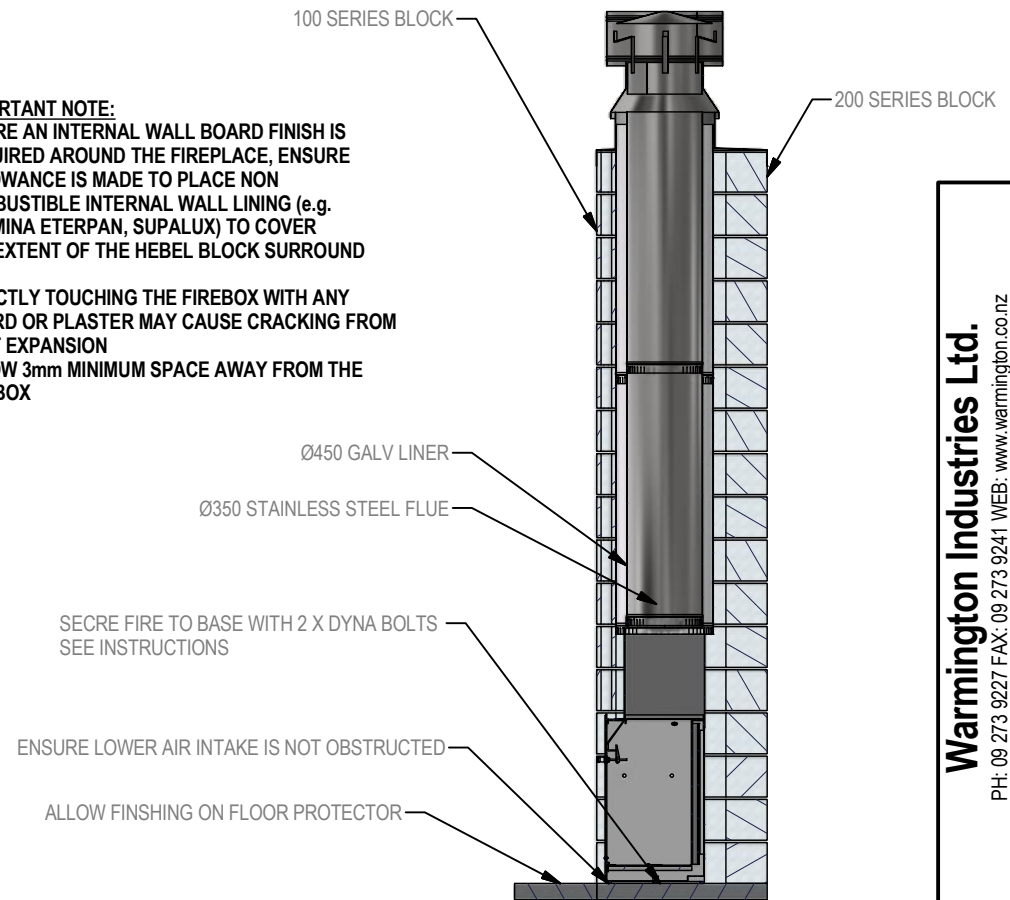

<b>Warmington Industries Ltd.</b>			
PH: 09 273 9227 FAX: 09 273 9241 WEB: <a href="http://www.warmington.co.nz">www.warmington.co.nz</a>			
TITLE	SN 1100 BLOCK ENCLOSURE	DATE	16/08/17
DRAWN	EMLYN	REVISION	02
SCALE	NOT TO SCALE		