

SG & EG 600-700-780-900-1100 Burner Only

Burner Only Installation Guide Only

Traditional

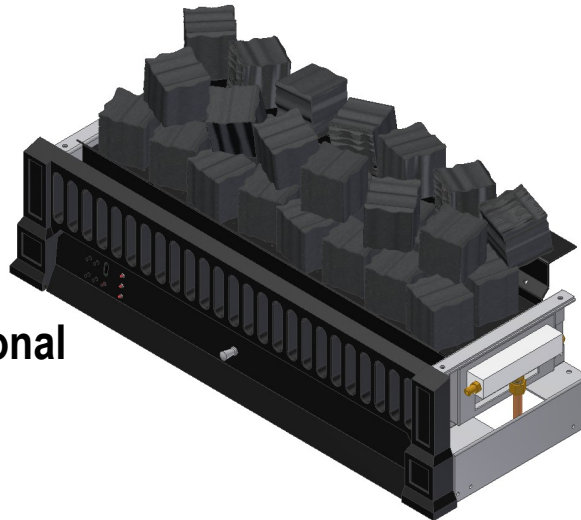

**Pure
Grate**

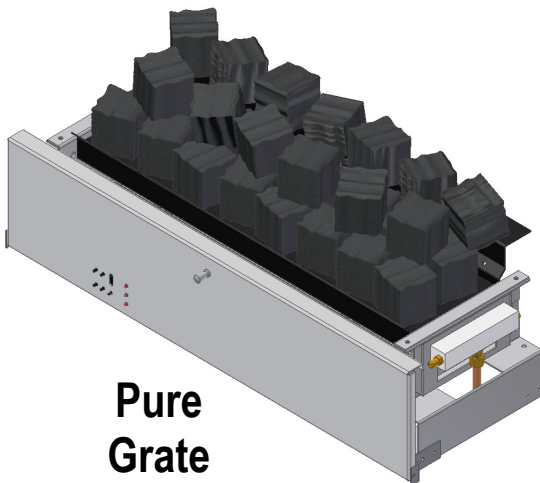

Classic Grate

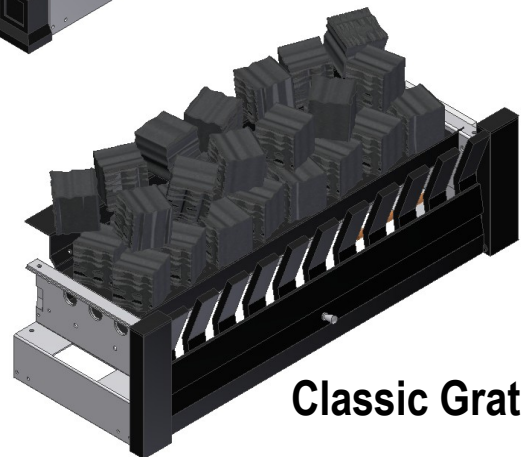

Related documents

Fire and flue system installation, and instructions to comply with NZS 5601.1:2013, 3645.1(Int):2010, 3645.2(Int):2010, 5266:2014, 2918:2001.

The fireplace is constructed and tested to comply with NZS 4558(int):2013 “Decorative gas log and other fuel effect appliances”.

Keep these instructions for further reference. Ensure that you have the correct and current installation details for the Warmington fireplace.

Installation

The Warmington unit is to be installed by a certified Warmington installer or an approved NZHHA installation technician.

See www.homeheat.co.nz/members for a certified NZHHA SFAIT Installer in your area.

A licenced certified gas fitter and licenced electrician are required to run power and gas supplies as required to the unit and any commissioning as part of the installation process. The heater must be installed according to these instructions and in compliance with all relevant building, gas fitting, electrical and other statutory regulations.

IMPORTANT

Read all the instructions carefully before commencing the Installation. Failure to follow these instructions may result in a fire hazard and void the warranty

POINTS TO CONSIDER PRIOR TO INSTALLATION

Location of the Fire. Open Fires are better located at one end of a room or area, as they project the heat away from their opening .

Venting to the Cavity.

This air is to allow the Cavity to Vent the Warm Air. This Warm Air helps keep the Fire and Flue System from getting to Cold . If the Flue and Fire get to Cold the System may soot often and require cleaning. Each Fire has different ways of venting the cavity .

The Topography of the Land .

The slope and position of the Land in relation to the Home has a bearing on how the wind will interact with the Fire and Flue System. Care needs to be taken to ensure that the Flue Termination is in the correct position to maximise performance .

The Prevailing Wind.

Care needs to be taken to ensure that the Flue Termination is in the correct position as wind and gusts that hits the Flue and Cowl System may overcome the Cowl and draft back down the Flue into the Home. This can be a combination of down draft and high pressure.

Hearth and Plinth:

The height of the Hearth off the Floor. The Finishing that is to be used on the hearth is to be allowed for at the design stage.

Positioning of the Flue System:

There is a maximum distance that an Offset Flue can be Installed. Reference to relevant standards.

Flue and Fire Clearance:

To be maintained to the Manufactures Instructions.

Pressure Differential, Venting & External Air into the Building :

All fires need air to burn and draw correctly, Kitchen Fans, Air Conditioning units, High Wind Zones, Naturally forming Draft spaces, can all have an effect on the pressure difference from inside the building to the outside. A lower pressure in the building may induce a draft down the flue system and back into the building causing the fire to smoke or spill into the building. **Care needs to be taken at the design and installation stage to adequately vent the building, or some mechanical system to ensure that there is always a neutral or positive pressure at the fireplace and a negative pressure at the flue outlet.** This will ensure that the draft in the flue system is always to the outside.

Wind Noise:

You may encounter wind noise in some installations. It is recommended to use an enclosed chase with a chimney pot to help reduce noise. There will always be some noise from the flue systems of all fireplaces.

INSTALLATION ORDER OF OPERATIONS

Prior to Construction and Installation

Important Notes:

1. **Consult a licenced certified gas fitter for correct gas installation.**
2. Install to current standards.
3. Install to manufacture's specifications.
4. All new Installations require a Local Council Consent No/Permit Application to be done .
5. Allow for Gas & Power supply to Cavity.
6. For special requirements concerning Materials (Timber Mantle and Surrounds) within close proximity of Warmington products, please contact your local Warmington Technical Consultant.

Install Procedure by Certified Gasfitter or approved "Warmington Installer", see "www.homeheat.co.nz" go to Members & follow steps to get a Certified NZHHA SFAIT Fire Installer in you Region. Installation to comply with current standards.

Ensure that the gas appliance is fitted and installed to the appropriate gas code and standard, and that all checks and test have been correctly carried out.

Maintenance:

Visually Inspect Fireplace and Flue System. Ensure that the Firebox is operating according to Manufacture's Instructions, Fire & Burner may Require to be serviced by Certified Gasfitter annually.

NOTE : See "IMPORTANT INFORMATION FROM THE STANDARD" in this specification.

These requirements are mandatory

IMPORTANT NOTES :
GAS SPECIFICATIONS Tested to current gas standards
NOTE : All Test Pressures are tested by a Independent Test Lab * Inlet Pressure not to exceed 4.0KPa

MODLE	SG-EG 600	SG-EG 700	SG-EG 780	SG-EG 900	SG-EG 1100
LPG					
Nominal Pressure kPa	2.75 kPa	2.75 kPa	2.75 kPa	2.75 kPa	2.75 kPa
Nominal Injector Size mm	2x 1.0 mm	2 X 1.1mm	2 X 1.2mm	2 X 1.3mm	2 X 1.4mm
Burner Pressure High kPa	2.50	2.5	2.5	2.5	2.5
Burner Pressure Low kPa	0.75	0.75	0.75	0.75	0.75
MJ/h	26	29	38	42	50
Flame Effect Output Only	Effect	Effect	Effect	Effect	Effect
Supply Pipe Size dia—min	3/8"	3/8"	3/8"	1/2"	1/2"
Natural Gas					
Nominal Pressure kPa	1.5kPa	1.5 kPa	1.5 kPa	1.5 kPa	1.5 kPa
Nominal Injector Size mm	2x1.6 mm	2 X 1.8mm	2 X 2mm	2 X 2.2mm	2 X 2.4mm
Burner Pressure High kPa	1	1	1	1	1.0
Burner Pressure Low kPa	0.3	0.3	0.3	0.3	0.3
MJ/h	27	35	45	41	58
Flame Effect Output Only	Effect	Effect	Effect	Effect	Effect
Supply Pipe Size dia—min	3/8"	3/8"	1/2"	1/2"	1/2"

Lab. Test No	CUB 008	GL 923	GL 900	GL 834	GL 876
Lab. Test Dates	13/08/2015	20/04/2010	26/02/10	26/06/09	24/12/09
ESS Declaration No:	n/a	1149420106	1149520106	1149720106	1149820106

WARMINGTON BURNERS

Burner		SG 600	SG 700	SG 780	SG 900	SG 1100
Burner Width	A	555	674	754	874	1074
Burner Height	B	205	205	205	205	205
Burner Depth	C	272	272	272	272	272
Flue Diameter Min	J	150	200	200	250	250
Flue CSA mm	K	17 671	31 416	31 416	49 087	49 087

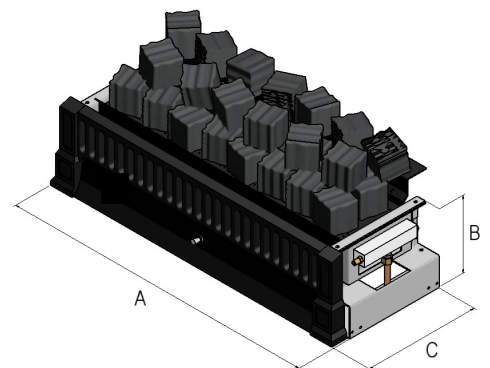
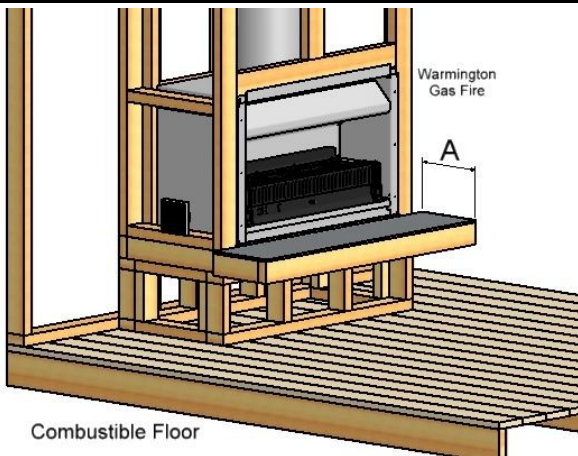
HEARTH CLEARANCES

Note: For Combustible Floors
Minimum Hearth of 300mm (A) must be maintained at any given height.

SG / EG Range: Gas Burners

TO THE INSTALLER / GAS FITTER and ELECTRICIAN

NOTES:

- Service annually or more if required.
- Custom built to clients requirements to relevant and current standards.
- The appliance and flue system must be installed in accordance with the relevant and current standards and the appropriate building codes.
- The appliance and flue system must be tested in accordance with the relevant and current standards and the appropriate building codes.

FLUED GAS APPLIANCES All Gas Fires requiring Warmington Flue Systems shall be Installed to the requirements of the current standards and shall be appropriately designed and constructed to permit safe and effective use. This Appliance must be flued to the outside atmosphere. All Warmington Fires must be Installed with a **minimum of 3.6m** of Approved **Warmington Gas Flue and Liners** .

GAS TYPE All Gas Fires shall operate safely on the Gas Type specified on the Appliance and shall comply with the requirements of The Gas Act 1992 .

APPLIANCE SAFETY Any gas fire appliance shall comply with the safety requirements of the current standards listed under "Related documents" in this specification.

ELECTRICAL REQUIREMENTS All Gas Fire Appliances Installed with Mains Supplied Electrical components for associated use with these Appliances, must comply with The Electricity Regulations 1993.

ELECTRONIC CONTROL SYSTEMS Any Gas Fire Appliance Installed with Manual or Programmable Electronic Control System shall be tested and/ or approved by a Recognised Person or Authority.

SEISMIC RESTRAINTS All Fires used for Domestic and Commercial Purposes shall be firmly secured (unless defined as portable or mobile) to prevent dislodgement from their point of fixture or Installation during Seismic Activity. Such Restraint must be of a reasonable expectation .

GAS CONNECTION

A Gas Certificate must be obtained for the Installation and Commissioning of this Appliance and Flue System .

Check that the Gas Type Specified on the Data Plate is correct for the available supply (LPG or NG).

A Copper Gas supply capable of supplying the correct MJ/h , should be brought into the rear of the Installation Cavity through the hole provided . A Flare Nut is provided on the Burner for Gas Connection to the Appliance .

COMMISSIONING AND TESTING OF FIREPLACE (To be carried out by Gasfitter)

Read all the instructions before commissioning. Install coals and logs and burner before commission.

Light appliance and check HIGH/LOW settings. Check operation of appliance and adjust to suit.

Adjust control valve setting if required. After a period of running (30min Plus) check the setting of the pilot and adjust if required. See Spec's for details.

Extinguish appliance, remove test equipment and secure test nipple. Check for Gas Leaks.

Note* The Control Valves are factory set and should not require adjustment.

GAS FITTER TO CARRY OUT STANDARD TESTING FOR COMMISSION:

- Spill test taken at top of opening with smoke or smoke match.
- Leak testing appliance and joints.
- Correct operation of the burner and coal and log lay out.
- Test gas pressures high and low, drop test on supply line.
- 5 second light time across burner. Other testing that may be required.
- Ventilation requirements to the standards.
- Clean and or touch up paint of fire box and burner
- Hand over to client, tests and comply to relevant standards.

FITMENT OF BURNER

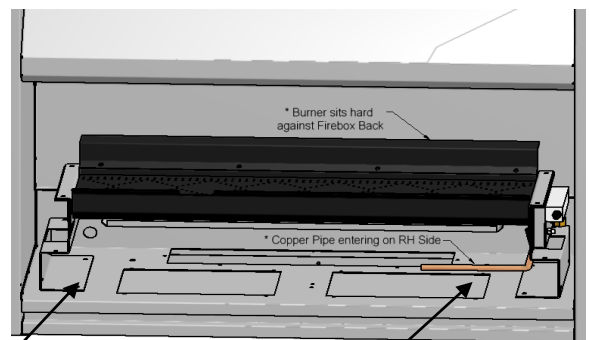

Burner may be Secured To the Firebox (Optional)

Gas Supply Pipe Into Fire , by Gasfitter . See Spec's for Pipe Size.

VERMICULITE (COURSE) (To be set by Gasfitter)

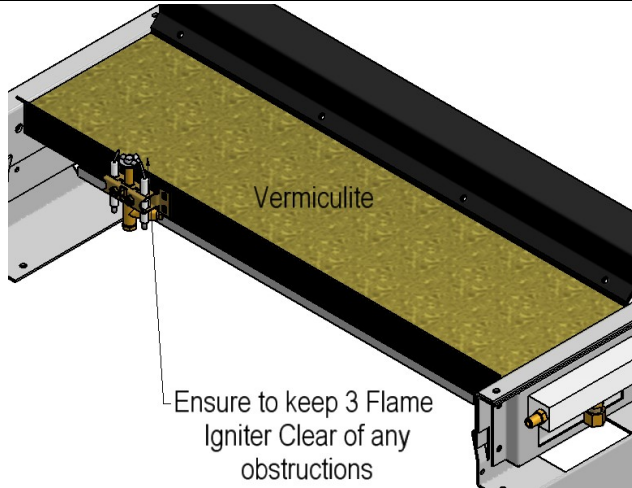

General Coal orientation fro optimum effect.

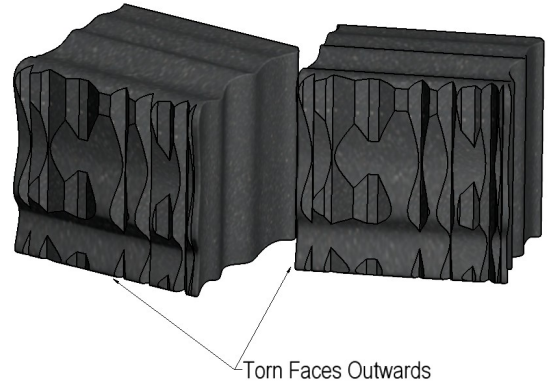

Apply a thin layer of Vermiculite over the Burner , just enough to cover the Burner Tray only .

COALS AND LOGS (To be set by Gasfitter)

Gloves should be worn when handling Ceramic Fibre Coals & Logs : care needs to be taken when handling Coals & Logs , Due to the Carbon on the Coals can stain the surroundings.

HELPFUL HINTS : When Hot use Metal Tongs.

Apply a thin layer of Vermiculite over the Burner , just enough to cover the Burner Tray only as shown above.

1 : Bottom Row : Assemble 2 Bottom Rows of Coals onto the Vermiculite Base . **2 : Top Row** : Assemble 2 Top Rows of Coals onto the Bottom Row .

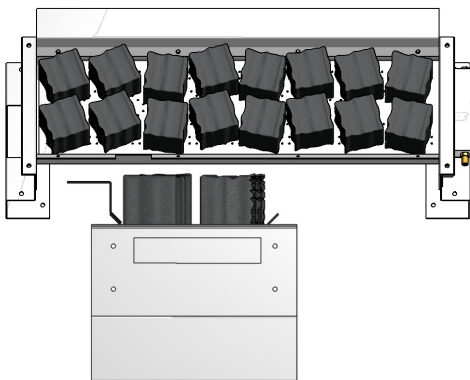

1 : Bottom Row

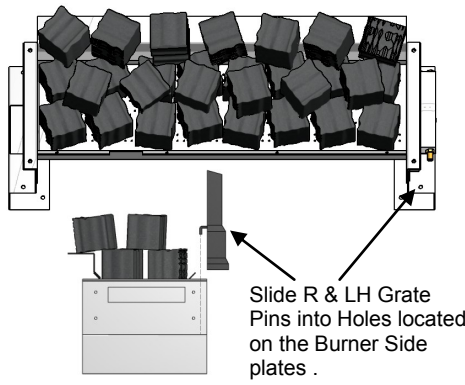

2 : Top Row

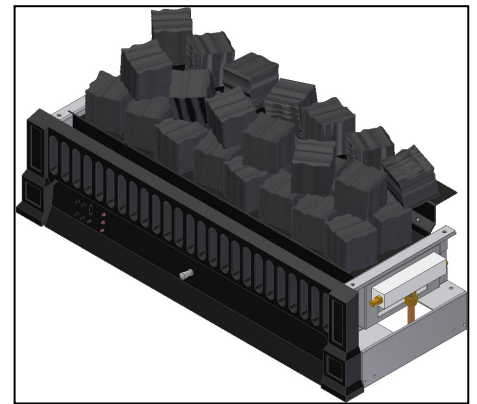

Model SG780 Shown: Total number of coals will vary per model.

Each Coal randomly positioned with the Torn (roughest) Face Outward . **Ensure Coal positioning does not directly block the 3 Flame Pilot .**

The placement of the Coals & Logs may vary to make an even Flame Pattern .

Logs and Twigs may be scattered to achieve best Visual Effect .

Fit Burner Grate by sliding R & L Side Metal Pins on Grate, into Holes Located on Burner Side Plates , as shown below .

Model	Number of Coals per Row		Number of Rows		Total Coals
	Top	Bottom	Top	Bottom	Total
SG / EG 600	6	5	2	2	22
SG / EG 700	5	6	2	2	22
SG / EG 780	6	8	2	2	28
SG / EG 900	9	10	2	2	38
SG / EG 1100	10	11	2	2	42

SG 600-700-780-900-1100 Burner

Burner Only Installation Guide Only

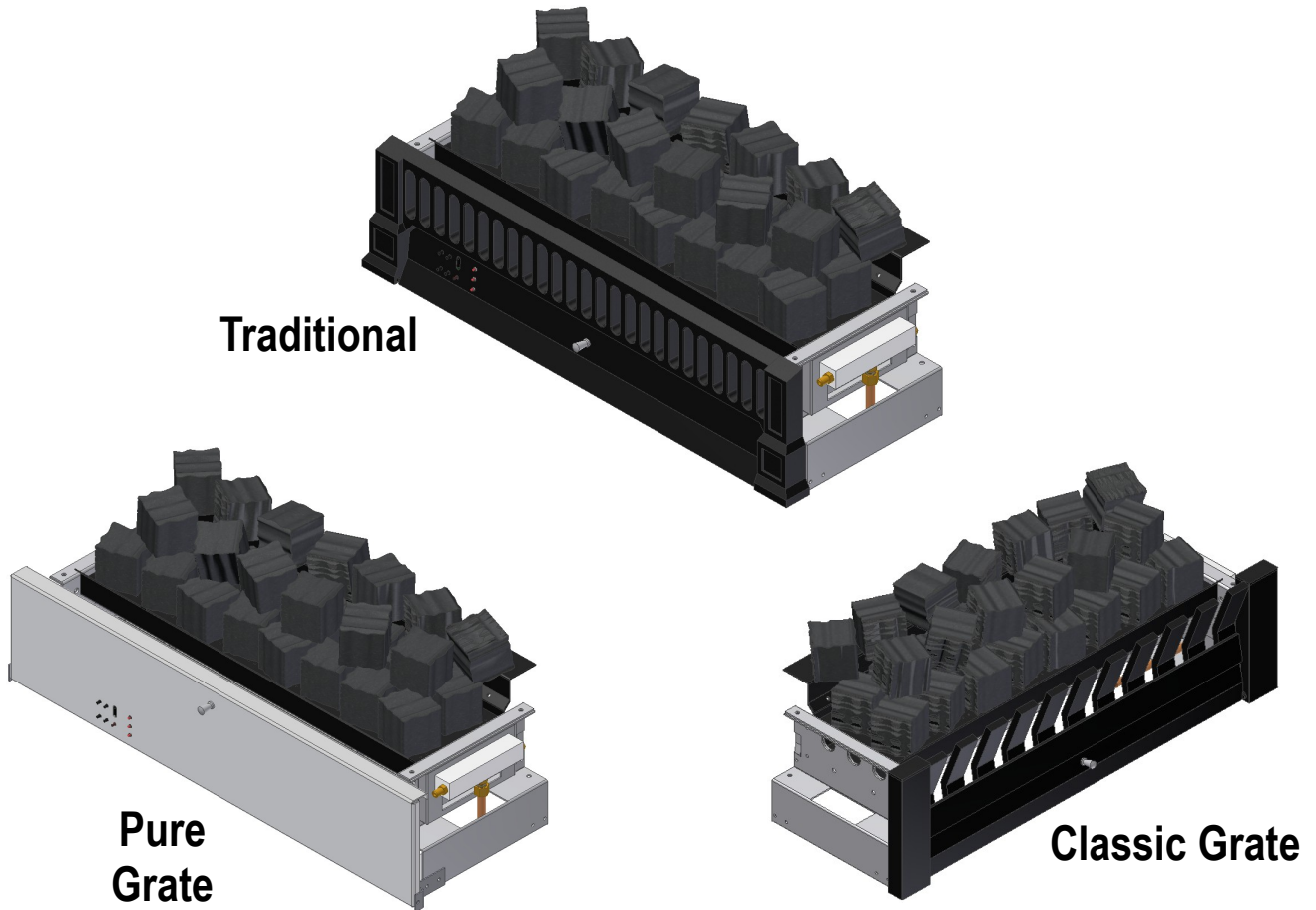

NOTE: IMPORTANT INFORMATION FROM THE STANDARD

Installation to comply with current standards. When installing a fitted open gas fire with an existing chimney section 6.7.11 in NZS 5601 is particularly relevant, see quote below:

6.7.11 Use of existing flue or chimney

An existing chimney or *flue* shall be used for flueing a *gas appliance* only after examination and the correction of any faults.

NOTE: Poor design of existing *flues* and chimneys can cause *combustion products* to enter into the room.

An existing chimney or *flue* that has been used for fuel other than *gas* shall be—

- (a) swept clear of soot and other loose material;
- (b) checked for soundness of construction and freedom from leakage; and
- (c) checked for adequate size.

Any damper plate shall be removed or permanently fixed fully open, except where a damper is necessary and in accordance with the *manufacturer's relevant instructions*.

OPTIONAL : BURNER RESTRIANTS .

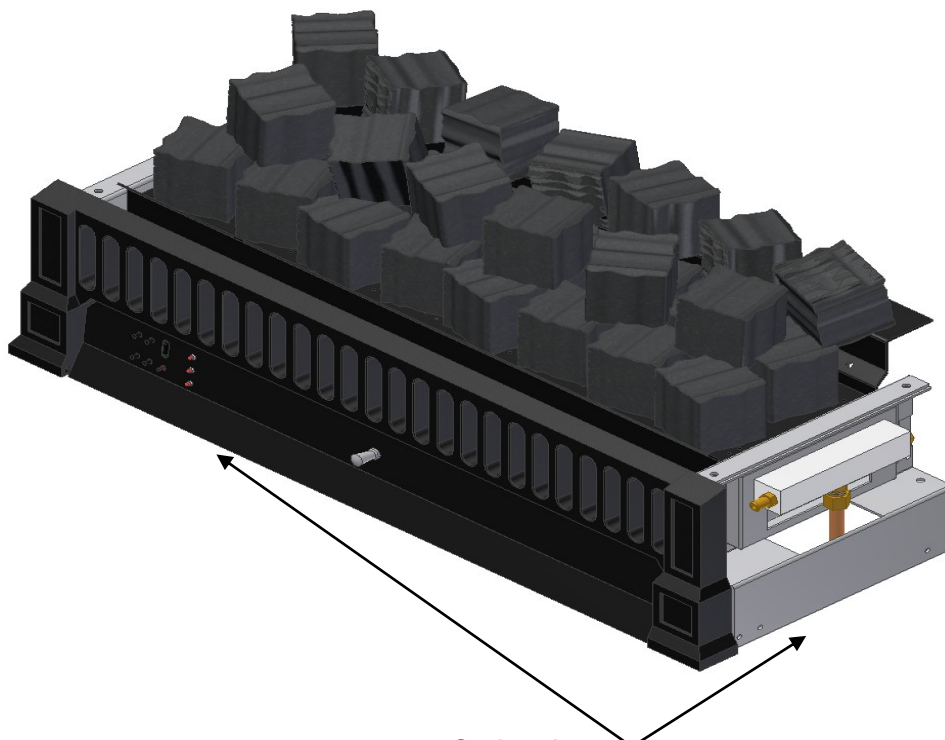

Optional :
Seismic Restraint
 Secure Burner through 4X anchor points provided on Burner Side Plate Bases

OPERATION OF YOUR WARMINGTON GAS CONVECTION FIRE (SG ONLY)

Your Fire must be Installed and Tested by a suitably qualified Gasfitter prior to use.

Instructions for lighting the gas fire:

Open the front cover by pulling in outwards.

Push in the ignition control switch and hold in the 'PILOT' position for 5-10 seconds until you can hear the gas come through the pipe – making sure the ignition switch is pressed in firmly.

To strike the igniter, turn anti clockwise to the * STAR position (with the ignition switch still firmly pressed in) until you hear the pilot ignite with a 'click'. Repeat this process 2 or 3 times if necessary.

Once the pilot flame is lit, hold this position for 3-5 seconds, then gently let the ignition switch out, and set the flame control to high. It may take a few seconds for the burner to light all the way across.

Once the flame is established, adjust to the desired setting and close the cover.

To shut down the gas fire:

Open the cover by pulling it outwards.

Turn the control ignition switch to 'PILOT' and the flame bed will extinguish.

Pilot light may be left on and the pilot flame will still burn.

To fully extinguish, turn to the 'OFF' position before closing the cover.

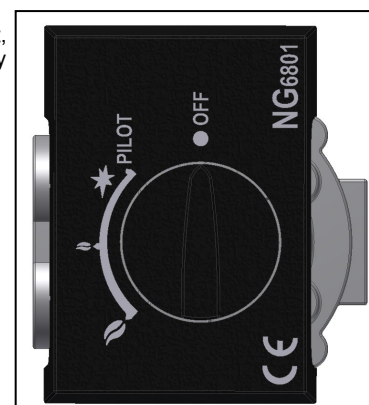

ADJUSTMENT OF HI—LOW PRESSURE

(SG ONLY)

(Only to be Adjusted by Gasfitter)

Adjustment of High & Low Settings Must be Carried out by a Certified Gas Fitter Only .

Note* Control Valves are Factory Set but may require adjustment onsite .

Turn Appliance Off & Remove Front Plastic Cover on Igniter , Pull Cover to Slide off .

Unscrew Test Nipple on the Burner Manifold & fit the Test Gauge Securely - See Diagram

* To Set the High : Light the Burner & turn to High - Then Adjust the High Screw to the Desired Pressure . See Spec's

* To Set the Low : Light the Burner & turn to Low - Then Adjust the Low Screw to the Desired Pressure . See Spec's

Extinguish Appliance, remove Test Equipment and Secure Test Nipple .

* Check Valve & Burner for Correct Operation & check Fire for Gas Leaks .

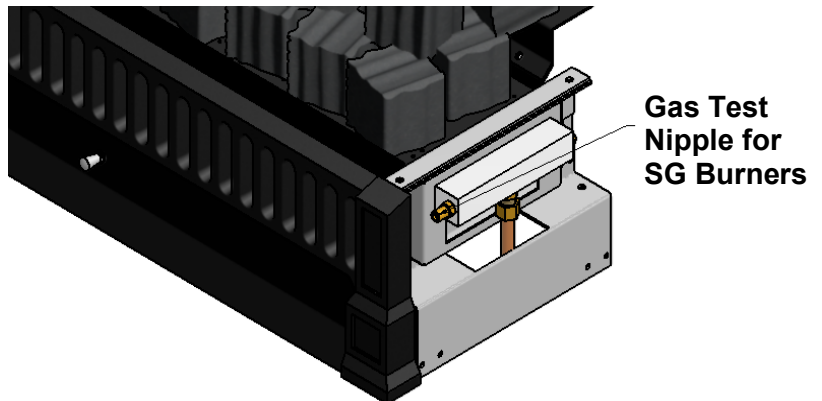
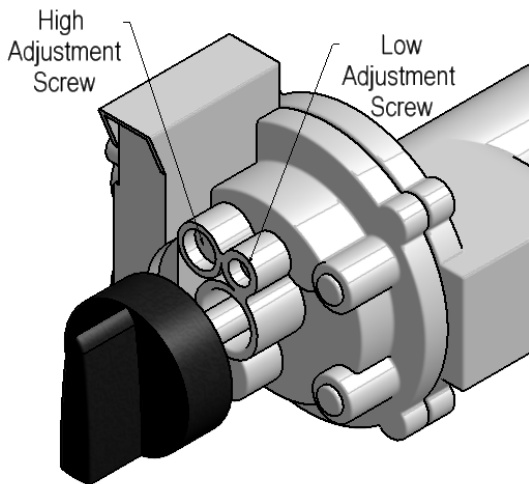

Note : Location of the Test Nipple - may vary from Model to Model

ADJUSTMENT OF THE PILOT—3 FLAME

(BOTH SG & EG)

(Only to be Adjusted by Gasfitter)

Note: When the Base screw is removed, gas will leak from the out let, ensure that the pilot is not adjusted or the screw is removed when the fire is burning.

- Adjustment of Pilot - 3 Flame : Unscrew Base Screw as shown in Diagram 2 .
- Insert a Screw Driver as shown in Diagram 3 and adjust the Adjustment Screw up inside the 3 Flame Pilot to adjust the Flame Height .
- The Flame must always be passing over the Electrodes &/or File Tube on either side .
- Replace the Base screw and check for leaks.

Note: to Gas Fitters

The 3 flame pilot may need adjustment after a period of running time on set up as the increase in heat in the fire will induce a higher draft in the fire, and may pull in flame away from the File Tube causing the fire to shut down.

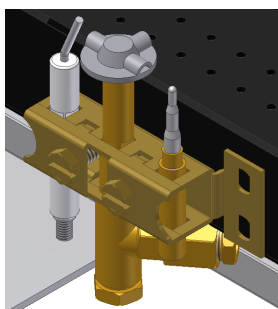

3 Flame Pilot in Assembled State

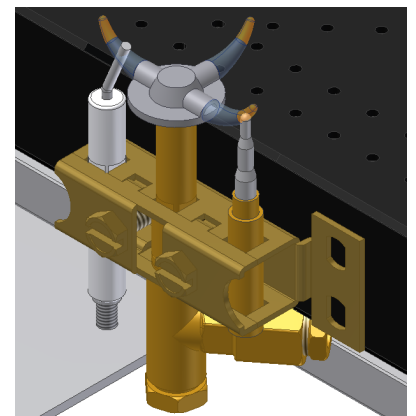
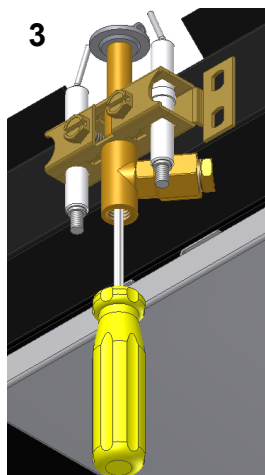
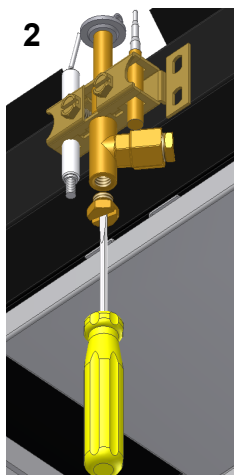

Correct Operation of 3 Flame Pilot

EG On/Off 600-700-780-900-1100 Burner

Burner Only Installation Guide Only

Traditional

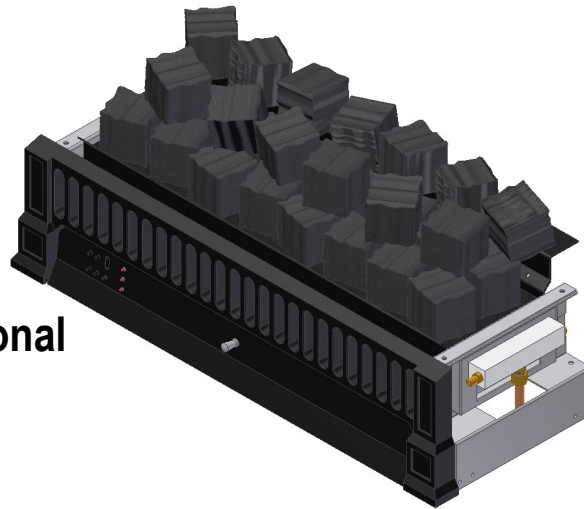

Pure
Grate

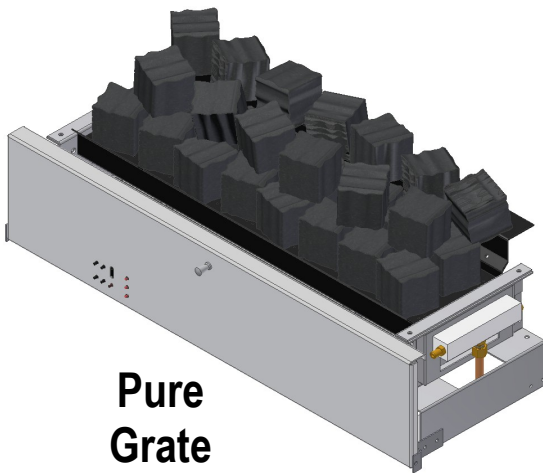

Classic Grate

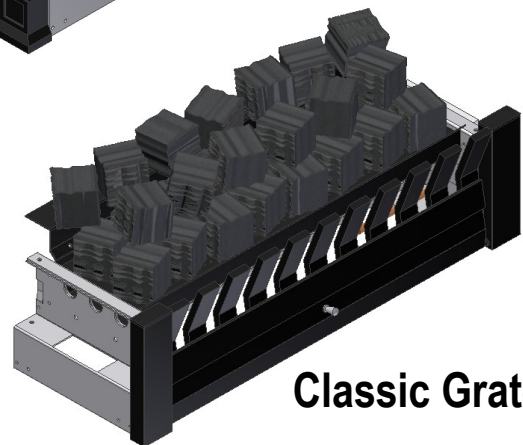

NOTE: IMPORTANT INFORMATION FROM THE STANDARD

Installation to comply with current standards. When installing a fitted open gas fire with an existing chimney section 6.7.11 in NZS 5601 is particularly relevant, see quote below:

6.7.11 Use of existing flue or chimney

An existing chimney or *flue* shall be used for flueing a *gas appliance* only after examination and the correction of any faults.

NOTE: Poor design of existing *flues* and chimneys can cause *combustion products* to enter into the room.

An existing chimney or *flue* that has been used for fuel other than *gas* shall be—

- (a) swept clear of soot and other loose material;
- (b) checked for soundness of construction and freedom from leakage; and
- (c) checked for adequate size.

Any damper plate shall be removed or permanently fixed fully open, except where a damper is necessary and in accordance with the *manufacturer's relevant instructions*.

PROCEDURE FOR THE TEST AND COMISSIONING OF YOUR DECORATIVE BURNER

Ensure Gas Supply and the Power Supply (caution 240V) to the Unit.

- Refer to Data Plate on this Specification for settings. The Data Plate is attached to the under carriage of the Burner .
- Loosen the Jet Test point and attach manometer (Digital is preferred). The Test Point is on the Right Hand Side of the Gas Burner , as Shown Below .

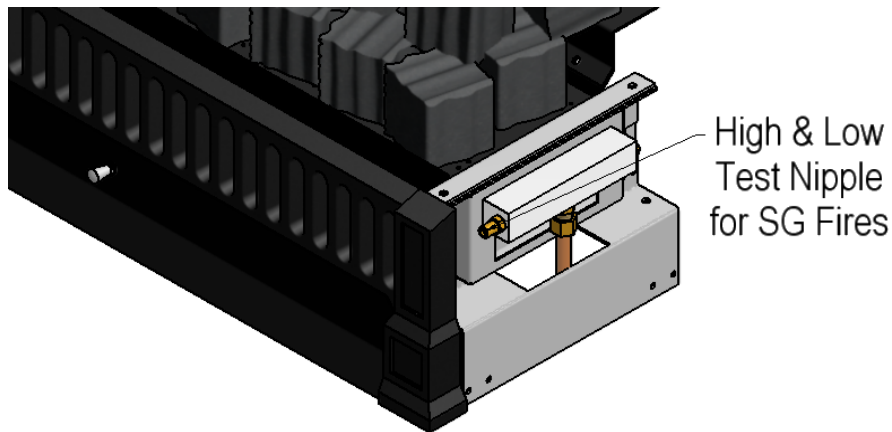

Note : Location of the Test Nipple - may vary from Model to Model

- Light Appliance and check the pressure to the Hi kPa value in the Table for maximum output.

NOTE : If setting the Pressure is required it is to be carried out by a Certified Gas Fitter.

- If adjustments are necessary, remove the dust cap on the control valve. The Pressure Adjustment Screw is on the Front Side of the Gas Control Valve (shown in Diagram **B** in this specification) and are **Factory** set.

Pressure Setting: Set the pressure to the Hi kPa value in the table for maximum output. The burner will operate any pressure between the hi and the low pressures.

Pressure Setting: Turn the Burner on with the switch and wait for full ignition. Screw the adjusting screw clockwise to Increase the Outlet Pressure or screw counter clockwise to Decrease the Pressure to the desired settings . Use a standard screw driver.

WARNING: Ensure that the dust cap is replaced after adjustment

DIAGRAM B (SHOWING CONTROL VALVE WITH TEST POINTS AND ADJUSTING SCREW).

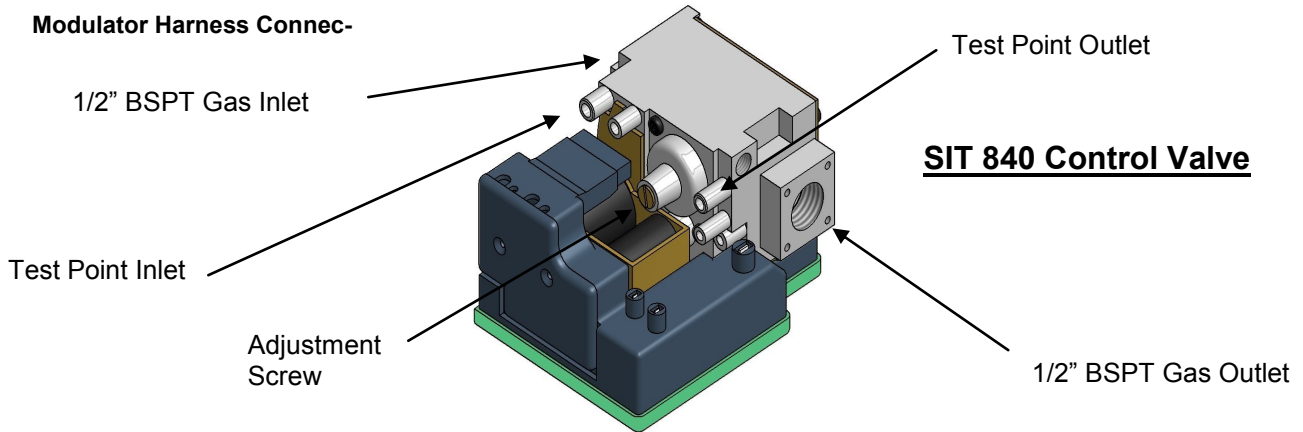

- After checking the pressure, turn the unit off, remove Manometer from the Test Point and Tighten the Test Point Screw. Ensure to check for gas leaks.
- Turn the Appliance On and Off a few times to check ignition.
- When you are satisfied that the Appliance is working correctly , fit the Front Panel Assembly back to the Gas Burner.
- NOTE : Ensure you peel the Protective Plastic Coating from any Stainless Steel components if fitted.
- All Burner Aerations are Factory Preset and cannot be adjusted.
- If you are unable to get the unit to operate correctly, refer to troubleshooting before contacting your Local Service Contact as listed.
- It may take approximately 2 hours of operation for the coals/Logs or river rocks to achieve their full flame pattern and glow.
- During the Initial Burning in period, some smoke and smell may be experienced , the appliance should be run in a well ventilated room until these dissipate .

ADJUSTMENT OF THE PILOT—3 FLAME (BOTH SG & EG) (Only to be Adjusted by Gasfitter)

Note: When the Base screw is removed, gas will leak from the out let, ensure that the pilot is not adjusted or the screw is removed when the fire is burning.

- Adjustment of Pilot - 3 Flame : Unscrew Base Screw as shown in Diagram 2 .
- Insert a Screw Driver as shown in Diagram 3 and adjust the Adjustment Screw up inside the 3 Flame Pilot to adjust the Flame Height .
- The Flame must always be passing over the Electrodes &/or File Tube on either side .
- Replace the Base screw and check for leaks.

Note: to Gas Fitters
 The 3 flame pilot may need adjustment after a period of running time on set up as the increase in heat in the fire will induce a higher draft in the fire, and may pull in flame away from the File Tube causing the fire to shut down.

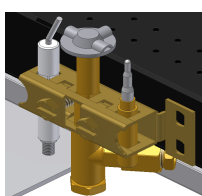

3 Flame Pilot in

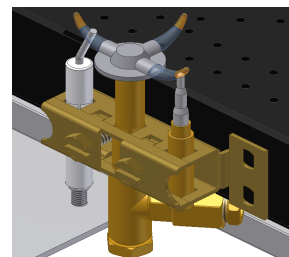
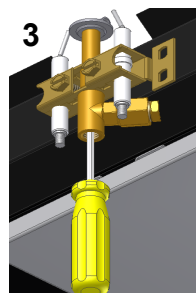
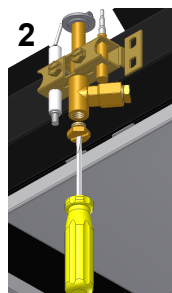

Correct Opera-

GAS ON-Off SCHEMATIC DIAGRAM

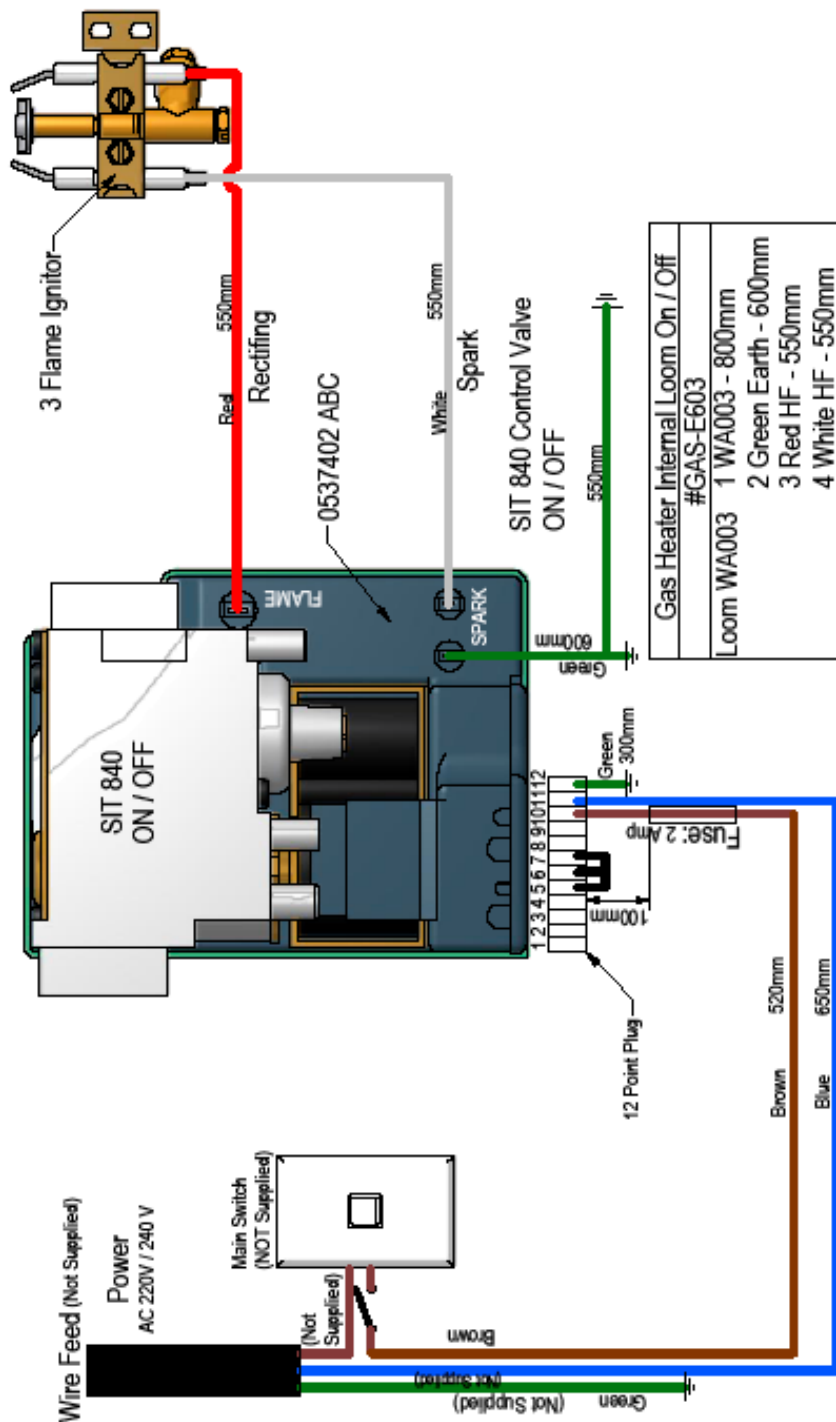

EG Hi/Low 600-700-780-900-1100 Burner

Burner Only Installation Guide Only

Traditional

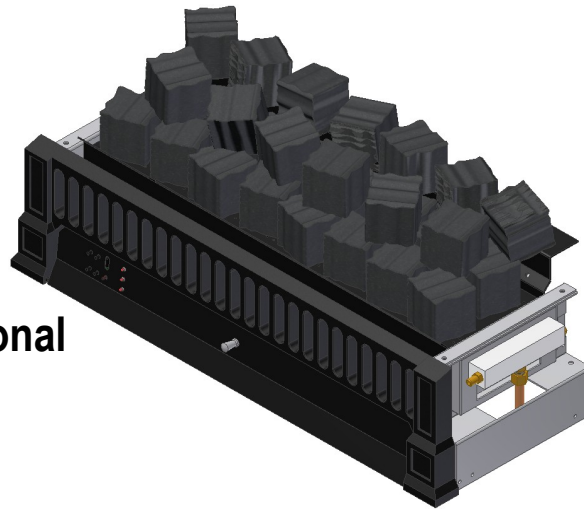

Pure
Grate

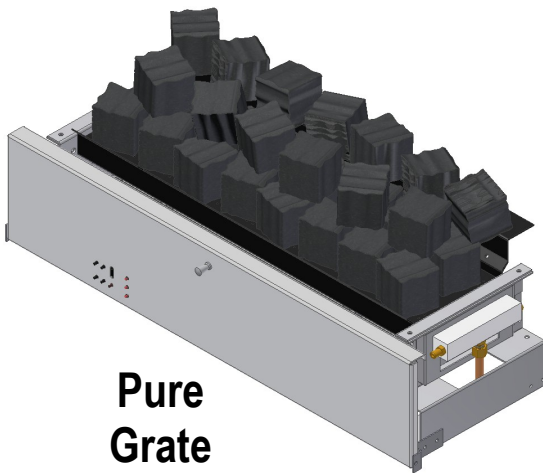

Classic Grate

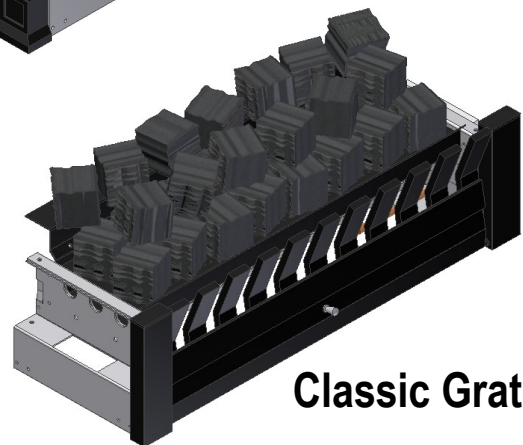

NOTE: IMPORTANT INFORMATION FROM THE STANDARD

Installation to comply with current standards. When installing a fitted open gas fire with an existing chimney section 6.7.11 in NZS 5601 is particularly relevant, see quote below:

6.7.11 Use of existing flue or chimney

An existing chimney or *flue* shall be used for flueing a *gas appliance* only after examination and the correction of any faults.

NOTE: Poor design of existing *flues* and chimneys can cause *combustion products* to enter into the room.

An existing chimney or *flue* that has been used for fuel other than *gas* shall be—

- (a) swept clear of soot and other loose material;
- (b) checked for soundness of construction and freedom from leakage; and
- (c) checked for adequate size.

Any damper plate shall be removed or permanently fixed fully open, except where a damper is necessary and in accordance with the *manufacturer's relevant instructions*.

PROCEDURE FOR THE TEST AND COMISSIONING OF YOUR DECORATIVE FIRE.

Ensure Gas Supply and the Power Supply (caution 240V) to the Unit.

- Refer to Data Plate on this Specification for settings. The Data Plate is attached to the under carriage of the Burner .
- Loosen the Jet Test point and attach manometer (Digital is preferred). The Test Point is on the Right Hand Side of the Gas Burner , as Shown Below .

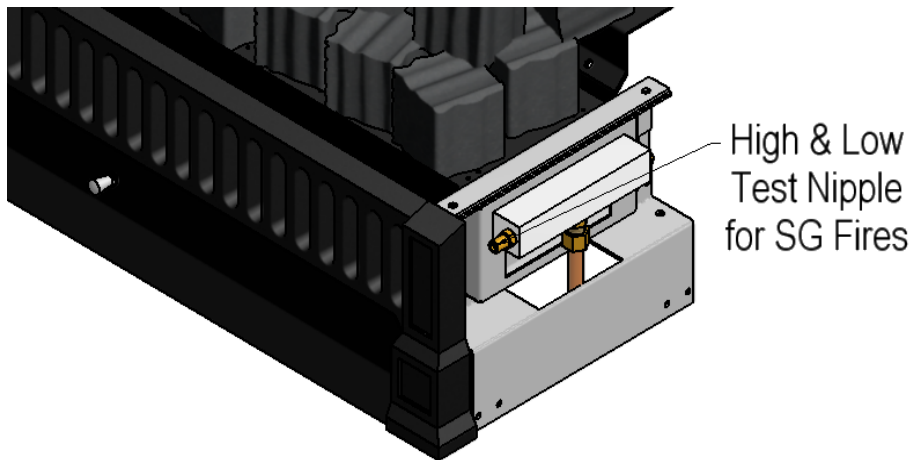

Note : Location of the Test Nipple - may vary from Model to Model

- Light Appliance, adjust to High Flame setting and check pressure, adjust to Low Flame and check pressure.

NOTE : If setting the Pressure is required it is to be carried out by a Certified Gas Fitter.

- If adjustments are necessary, remove the cap . The Pressure Adjustment Screw and Nut are on the Front Side of the Gas Control Valve (shown in Diagram **B** in this specification) and are **Factory** set.

High Pressure Setting: Set the Burner to High with the switch. Screw in **Nut A** to Increase the Outlet Pressure then screw Nut A out to Decrease the Pressure to the desired settings . Use 10mm spanner.

Low Pressure Setting: Set the Burner to Low with the switch - (See Wiring Diagram) and, keep Nut A stationary . Use a screwdriver to screw in **Screw B** to Increase the Pressure and Screw it Out to Decrease the Pressure . Carefully replace the Modulator Plastic Cap .

WARNING: To ensure the Correct Operation of the Hi/Low burner it is necessary that the Plastic Cap is returned to its original location .

DIAGRAM B (SHOWING CONTROL VALVE WITH TEST POINTS AND ADJUSTING SCREW).

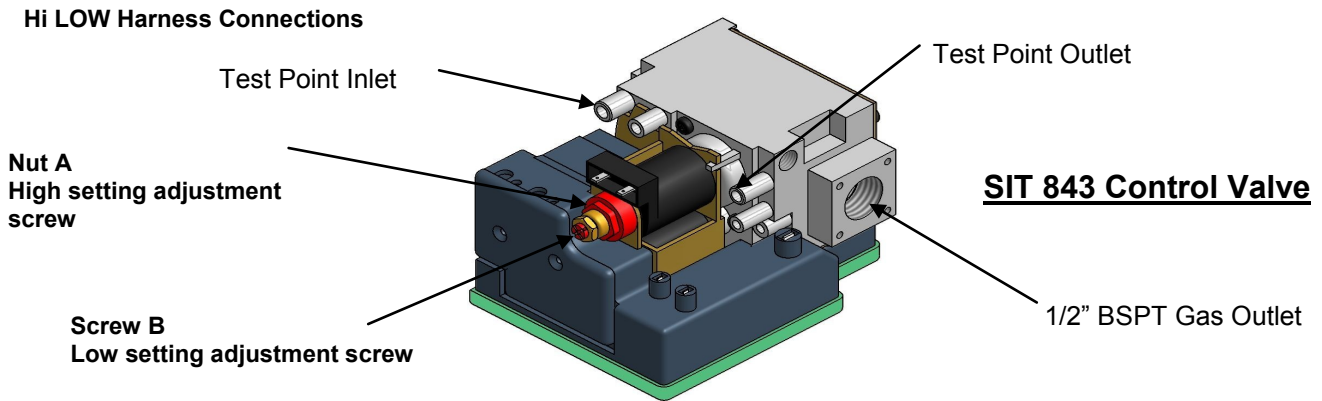

- After checking the pressure, turn the unit off, remove Manometer from the Test Point and Tighten the Test Point Screw. Ensure to check for gas leaks.
- Ensure Power is Off & Reconnect Modulator Harness Connection in the Main Harness. See Diagram B Above .
- Turn the Appliance On and Off a few times to check ignition.
- When you are satisfied that the Appliance is working correctly , fit the Front Panel Assembly back to the Gas Burner.
- NOTE : Ensure you peel the Protective Plastic Coating from any Stainless Steel components if fitted.
- All Burner Aerations are Factory Preset and cannot be adjusted.
- If you are unable to get the unit to operate correctly, refer to troubleshooting before contacting your Local Service Contact as listed.
- It may take approximately 2 hours of operation for the coals/Logs or river rocks to achieve their full flame pattern and glow.
- During the Initial Burning in period, some smoke and smell may be experienced , the appliance should be run on the high position in a well ventilated room until these dissipate .

ADJUSTMENT OF THE PILOT—3 FLAME (BOTH SG & EG) (Only to be Adjusted by Gasfitter)

Note: When the Base screw is removed, gas will leak from the out let, ensure that the pilot is not adjusted or the screw is removed when the fire is burning.

- Adjustment of Pilot - 3 Flame : Unscrew Base Screw as shown in Diagram 2 .
- Insert a Screw Driver as shown in Diagram 3 and adjust the Adjustment Screw up inside the 3 Flame Pilot to adjust the Flame Height .
- The Flame must always be passing over the Electrodes &/or File Tube on either side .
- Replace the Base screw and check for leaks.

Note: to Gas Fitters

The 3 flame pilot may need adjustment after a period of running time on set up as the increase in heat in the fire will induce a higher draft in the fire, and may pull in flame away from the File Tube causing the fire to shut down.

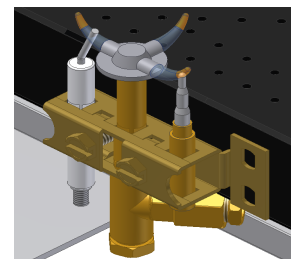
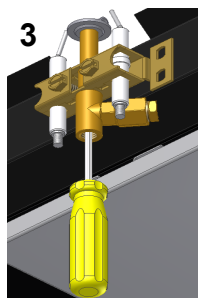
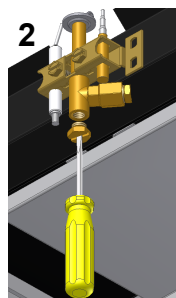
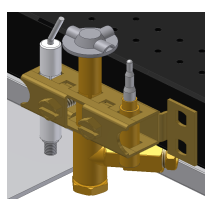

GAS HI/LOW SCHEMATIC DIAGRAM

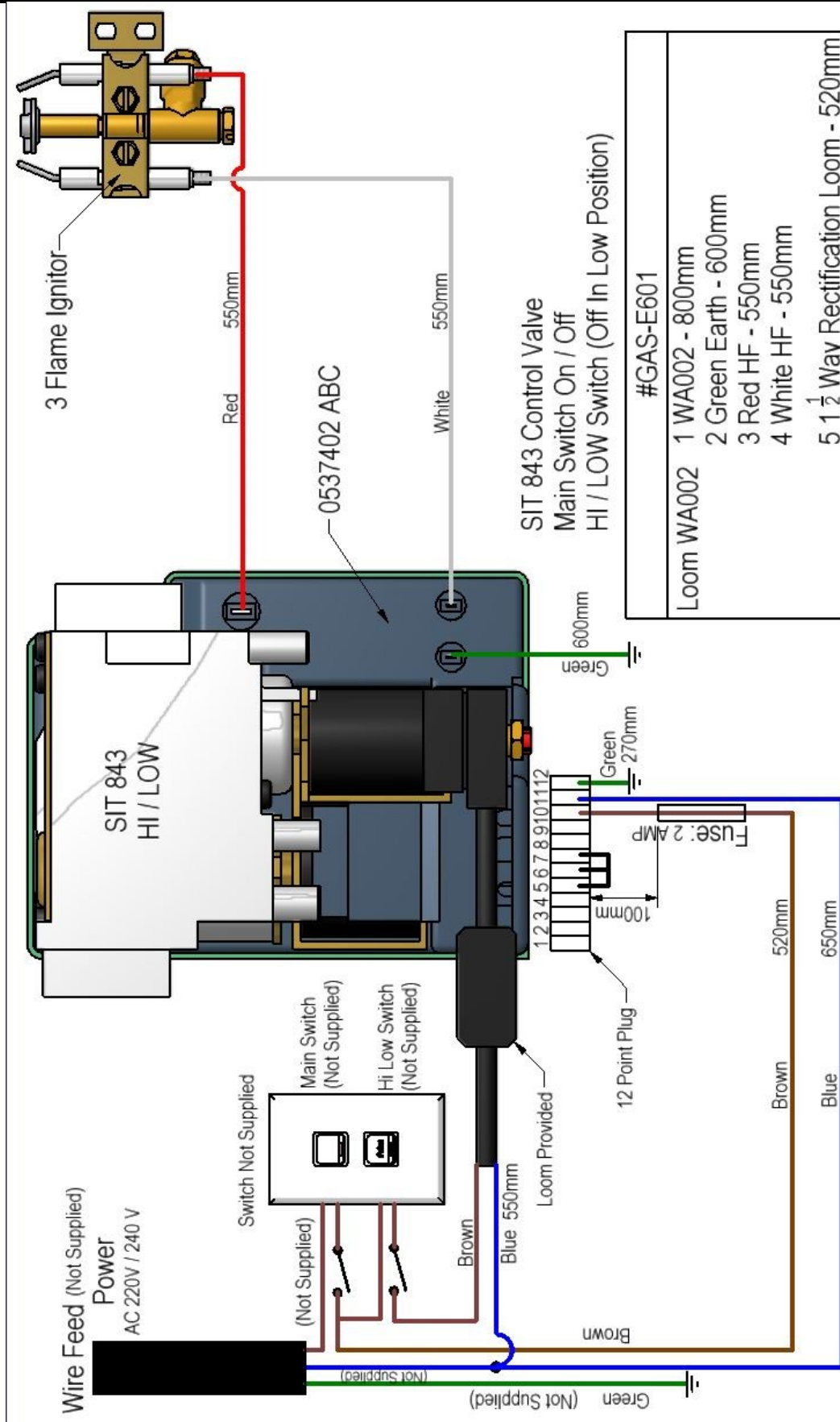

EG With Remote 600-700-780-900-1100 Burner

Burner Only Installation Guide Only

Traditional

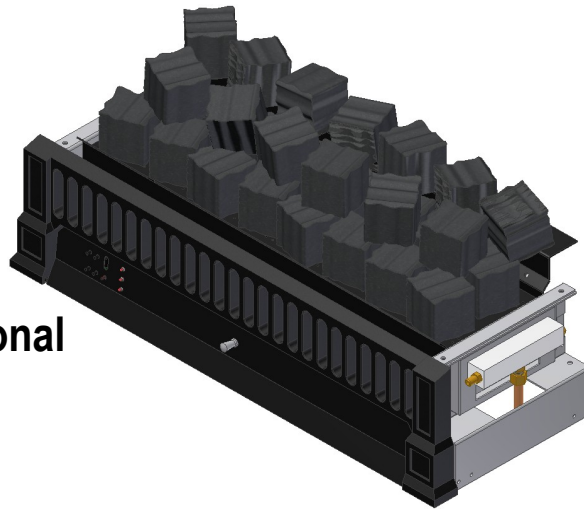

Pure
Grate

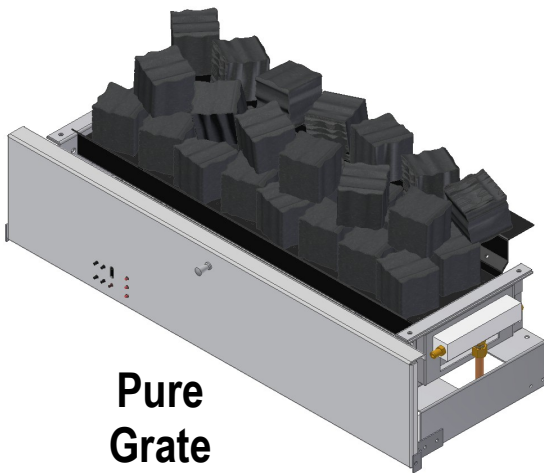

Classic Grate

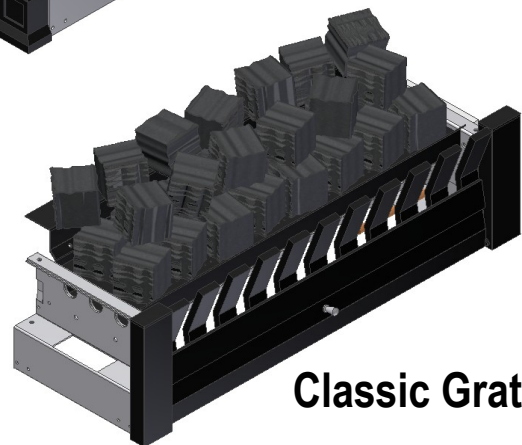

NOTE: IMPORTANT INFORMATION FROM THE STANDARD

Installation to comply with current standards. When installing a fitted open gas fire with an existing chimney section 6.7.11 in NZS 5601 is particularly relevant, see quote below:

6.7.11 Use of existing flue or chimney

An existing chimney or *flue* shall be used for flueing a *gas appliance* only after examination and the correction of any faults.

NOTE: Poor design of existing *flues* and chimneys can cause *combustion products* to enter into the room.

An existing chimney or *flue* that has been used for fuel other than *gas* shall be—

- (a) swept clear of soot and other loose material;
- (b) checked for soundness of construction and freedom from leakage; and
- (c) checked for adequate size.

Any damper plate shall be removed or permanently fixed fully open, except where a damper is necessary and in accordance with the *manufacturer's relevant instructions*.

OPERATION OF YOUR E.G GAS BURNER IGNITER ONLY

FOR MANUAL OPERATION OF YOUR EG WARMINGTON DECORATIVE BURNER

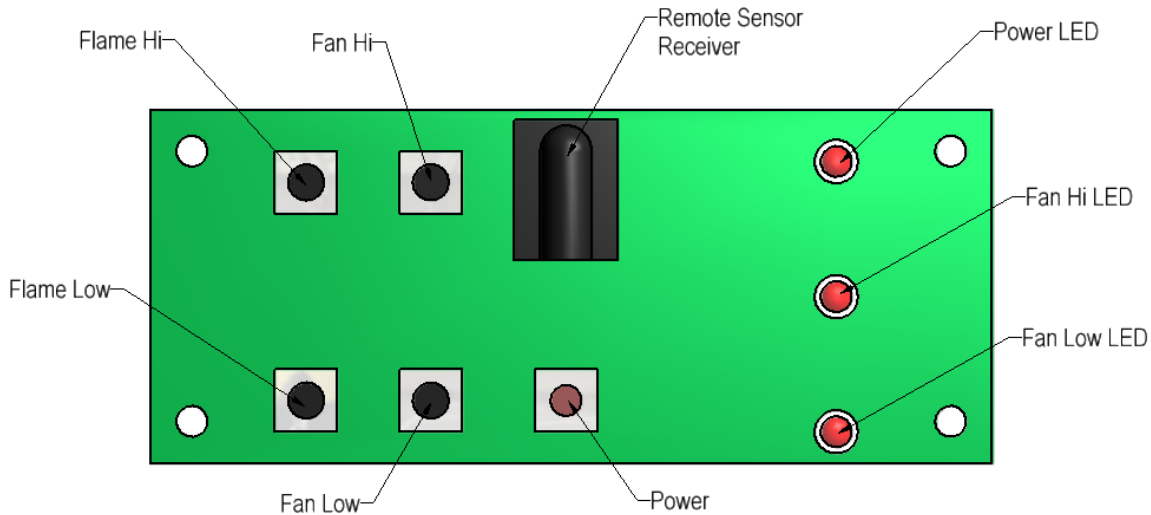

AS SHOWN FROM THE FRONT OF THE BURNER.

This Control Panel is Located on the Bottom Left Hand Side of your Warmington decorative Gas Burner.

Press and Release the Power Button. This will Start the Electronic Spark and the Power LED will be on Permanently. The Pilot will Ignite First, once this is on, it will ignite the Main Burner. Pressing and Releasing the Power Button again will Switch Off the Appliance.

When the Appliance is Turned On again, the Gas Fire will resume the previous Flame and Fan settings , unless the Appliance was Switched Off due to Power Failure. In the circumstance of a Power Failure the Remote Control System will return to the default settings which is a Low Flame and the Fan Turned Off.

If the Gas Fails to light, the Appliance it will go into Lock Out Mode , after trying to ignite for 1 minute (approx.) . In Lock Out Mode the Power LED will remain illuminated. To start the Appliance again Press and Release the Power Button Twice after the Gas Supply Resumes.

FLAME OPERATION

Press and Hold the + button to Increase the Main Burner Flame . Press and Hold the - button to Decrease the Main Burner Flame. By holding the + or - Flame Button for up to 10-15 sec this will Increase or Decrease the Main Burner Flame to it's Max or Min .

FAN OPERATION

The Stand alone EG Burner has no Fan fitted to it..

REMOTE CONTROL FEATURES

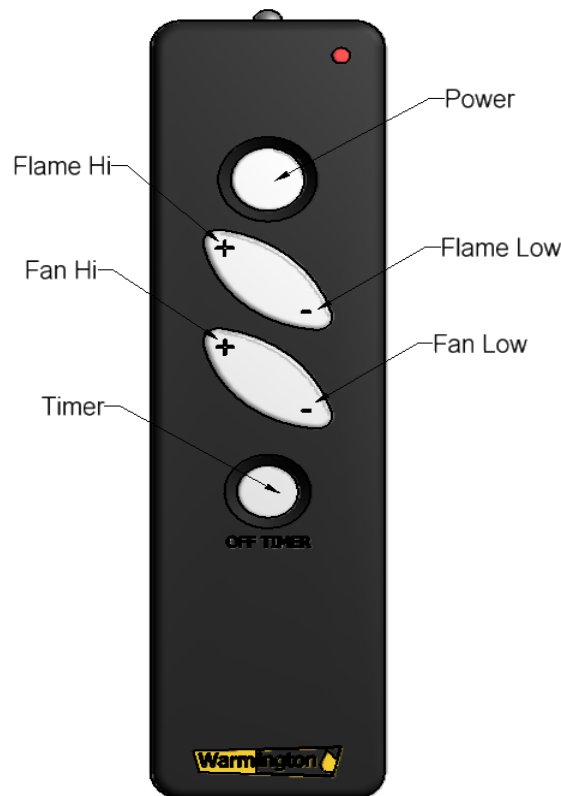

Your Remote Control has all the features of the Control Receiver situated on the Front Panel of the Burner .

By pressing Timer Button , the Power LED will start flashing and after 30 minutes the appliance will Shut Off Automatically .

By pressing the Timer Button again within the 30 minute period, this will reset the Timer and the power LED will Stop Flashing .

IMPORTANT NOTE ABOUT YOUR WARMINGTON GAS BURNER

Warranty Cover will be considered void if failure to operate the appliance in accordance with the supplied Instructions and Specifications, or is subject to damage or misuse beyond the expected conditions of normal use which could result in injury or property damage .

PROCEDURE FOR THE TEST AND COMMISSIONING OF YOUR DECORATIVE BURNER.

Ensure Gas Supply and the Power Supply (caution 240V) to the Unit.

- Refer to Data Plate on this Specification for settings. The Data Plate is attached to the under carriage of the Burner .
- Remove Front Grate ensure the CAT5 cable to the Control Receiver is still connected.
- Loosen the Jet Test point and attach manometer (Digital is preferred). The Test Point is on the Right Hand Side of the Gas Burner , as Shown Below .

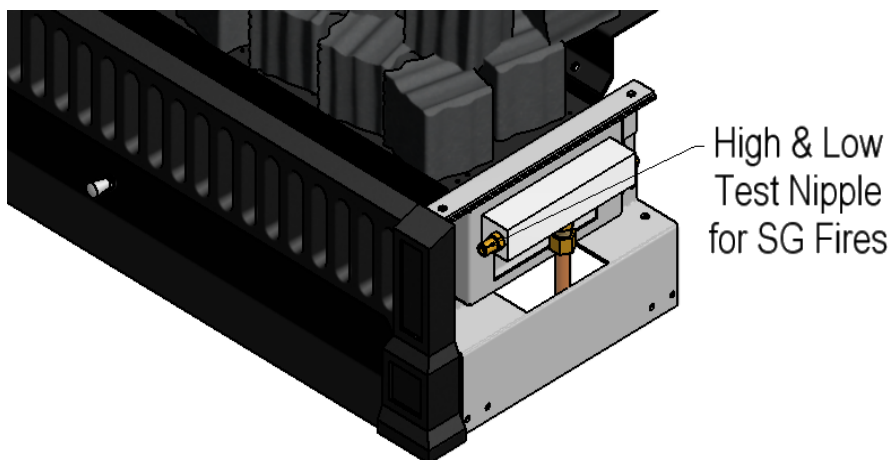

Note : Location of the Test Nipple - may vary from Model to Model

- Light Appliance, adjust to High Flame setting and check pressure, adjust to Low Flame and check pressure.

NOTE : If setting the Pressure is required it is to be carried out by a Certified Gas Fitter.

- If adjustments are necessary, remove the cap . The Pressure Adjustment Screw and Nut are on the Front Side of the Gas Control Valve (shown in Diagram B in this specification) and are **Factory** set.

High Pressure Setting: Set the modulator to Maximum Condition. Screw in **Nut A** to Increase the Outlet Pressure then screw Nut A out to Decrease the Pressure to the desired settings . Use 10mm spanner.

Low Pressure Setting: Turn Off the Power to the Modulator (by disconnecting the Modulator Harness Connection at the Valve - See Wiring Diagram in Page 17 .) and, keep Nut A stationary . Use a screwdriver to screw in **Screw B** to Increase the Pressure and Screw it Out to Decrease the Pressure . Carefully replace the Modulator Plastic Cap .

WARNING: To ensure the Correct Operation of the Modulator it is necessary that the Plastic Cap is returned to its original location .

DIAGRAM B (SHOWING CONTROL VALVE WITH TEST POINTS AND ADJUSTING SCREW).

Modulator Harness Connections

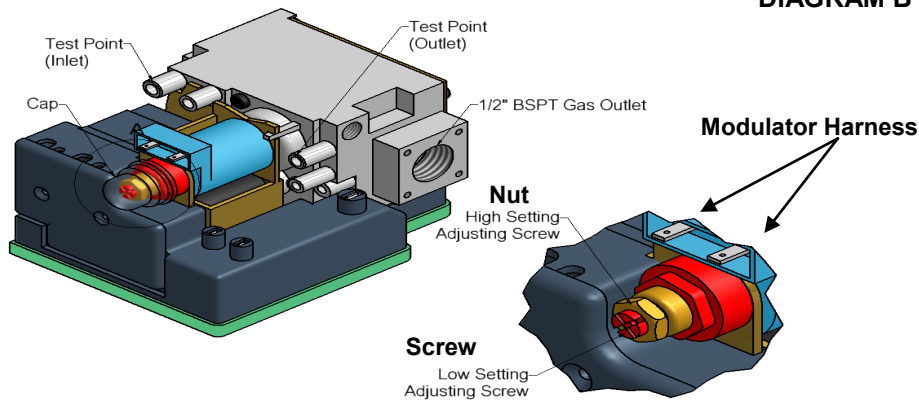

- After checking the pressure, turn the unit off, remove Manometer from the Test Point and Tighten the Test Point Screw. Ensure to check for gas leaks.
- Ensure Power is Off & Reconnect Modulator Harness Connection in the Main Harness. See Diagram B Above .
- Turn the Appliance On and Off a few times to check ignition.
- When you are satisfied that the Appliance is working correctly , fit the Front Panel Assembly back to the Gas Burner.
- NOTE : Ensure you peel the Protective Plastic Coating from any Stainless Steel components if fitted.
- All Burner Aerations are Factory Preset and cannot be adjusted.
- If you are unable to get the unit to operate correctly, refer to troubleshooting before contacting your Local Service Contact as listed.
- It may take approximately 2 hours of operation for the coals/Logs or river rocks to achieve their full flame pattern and glow.
- During the Initial Burning in period, some smoke and smell may be experienced , the appliance should be run on the high position in a well ventilated room until these dissipate .

ADJUSTMENT OF THE PILOT—3 FLAME (BOTH SG & EG) (Only to be Adjusted by Gasfitter)

Note: When the Base screw is removed, gas will leak from the out let, ensure that the pilot is not adjusted or the screw is removed when the fire is burning.

- Adjustment of Pilot - 3 Flame : Unscrew Base Screw as shown in Diagram 2 .
- Insert a Screw Driver as shown in Diagram 3 and adjust the Adjustment Screw up inside the 3 Flame Pilot to adjust the Flame Height .
- The Flame must always be passing over the Electrodes &/or File Tube on either side .
- Replace the Base screw and check for leaks.

Note: to Gas Fitters
 The 3 flame pilot may need adjustment after a period of running time on set up as the increase in heat in the fire will induce a higher draft in the fire, and may pull in flame away from the File Tube causing the fire to shut down.

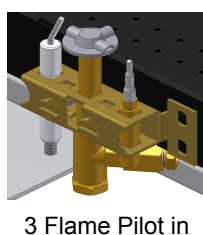

3 Flame Pilot in

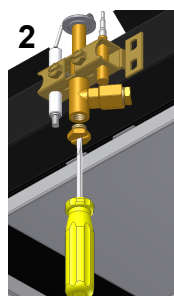

2

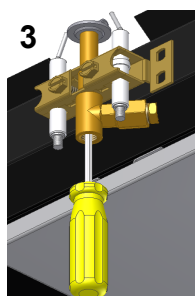

3

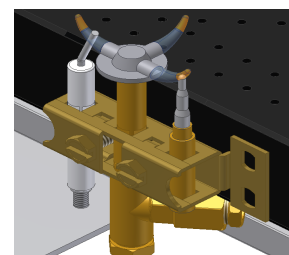

Correct Opera-

REMOTE IGNITION EG GAS FIRE WIRING DIAGRAM

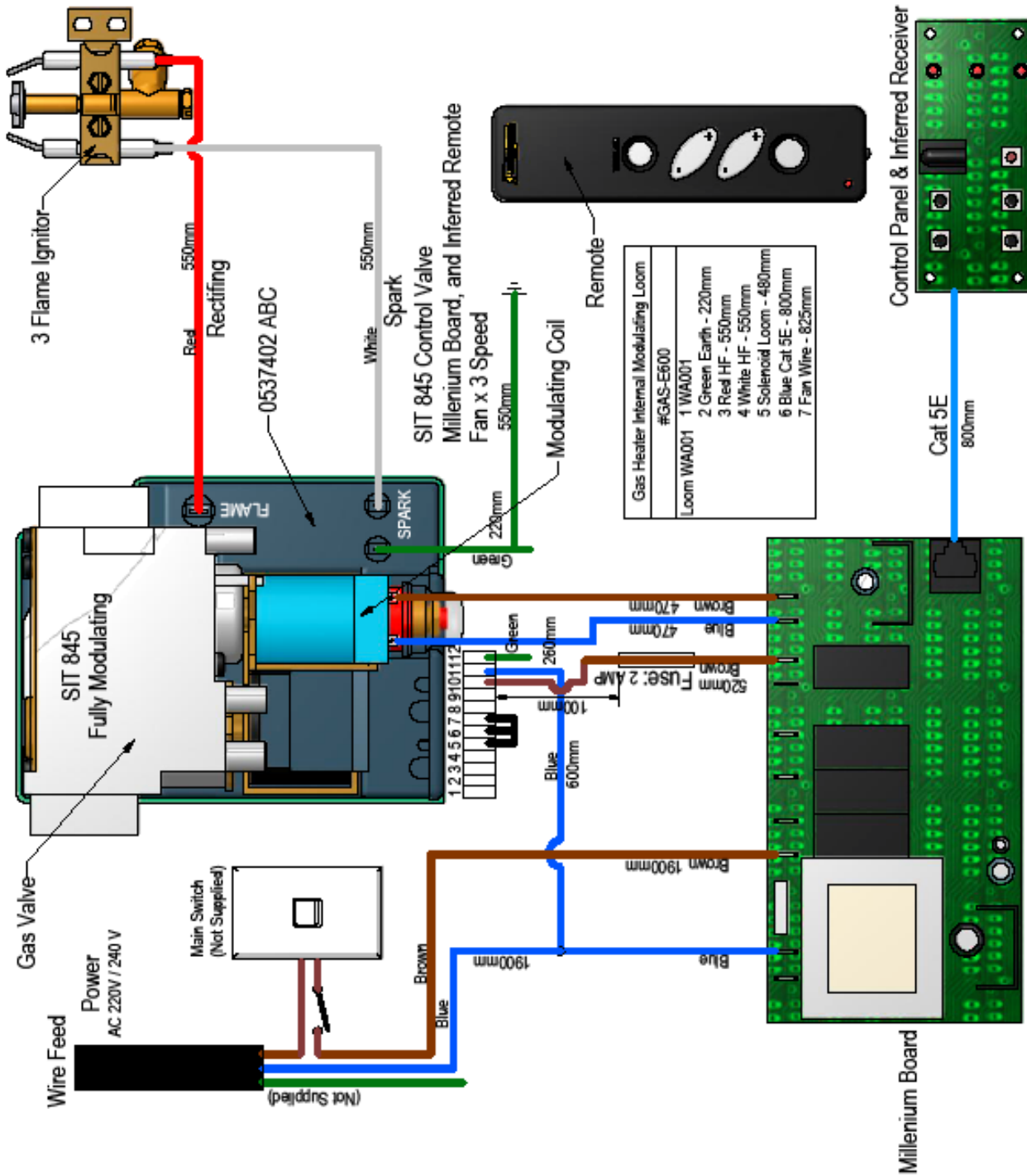

POINTS OF SAFETY—To the Customer /Home-Owner

Your Warmington Gas Decorative Burner operates on the principle of dual radiant and convected heat. Therefore it is important to observe the following precautions associated with any heating appliance or open fire.

- Do not cover or restrict the fireplace upper or lower vents in any way as this may result in a build-up of hazardous gases within the room.
- The fire is not intended for the drying of clothing, bedding etc.
- Avoid installing this appliance in high traffic areas, strong draughts or near drapes or furniture.
- The use of an approved fireguard is recommended for the protection of young children.
- Avoid using aerosols when the appliance is operating.
- Avoid anyone leaning against or lying directly in front of the fire while operating.
- Do not place anything objects into or against the gas fire or burner at any stage.
- The fire may release a small amount of smoke on its first start up which may take 1 or 2 hours to dissipate . This is part of the curing process so ensure there is adequate ventilation within the room.
- Always use a registered Gas Fitter or Electrician for installing and maintenance work
- Always use certified gas cylinders that have been tested and are safe to use.
- Never modify your gas appliance or its settings from those specified by the manufacturer.

APPLIANCE SAFETY Any gas fire appliance shall comply with the safety requirements of the current standards listed under "Related documents" in this specification.

ELECTRONIC CONTROL SYSTEMS Any gas Burner appliance fitted with manual or programmable electronic control systems shall be tested and/or approved by a recognised person or authority.

SEISMIC RESTRAINTS All gas Burner used for domestic and commercial purposes shall be firmly secured (unless defined as portable or mobile) to prevent dislodgement from their point of fixture or installation during seismic activity.

WHAT DO YOU DO IF YOU SMELL GAS

Open windows and doors

Do not light any gas appliance

Do not use any electrical appliance or switches

Do not use the telephone in your home

Leave the building; shut off the domestic gas supply valve (beside your meter)

Call your gas supplier/gas fitter or the Fire Service for further advice.

MAINTENANCE : All burner setting, Coals placement, Vermiculite is to be checked and set in accordance with this specification by the service person/Gas fitter

**Lighting your gas fire using electronic or remote ignition systems may vary as per manufacturer instructions*

Warmington Industries recommend annual servicing of your gas fire by an approved Warmington dealer Gas Fitter.

External surfaces should be dusted with a damp, lint-free cloth when the fire is cold.

Warmington Industries provide 12 months warranty from the date of purchase, for domestic or commercial installations

This Warranty Covers :

Replacement Parts and Labour for Gas Control Components due to Manufacturing Defects Only.

Repair or Replacement of the Burner or Firebox Components due to Manufacturing Defects Only.

Warranty cover will be considered void if the product is subject to incorrect installation, failure to operate the appliance in accordance with the supplied instructions and specifications or is subject to damage or misuse beyond the expected conditions of normal use.

All installations and servicing must be carried out by and approved Warmington dealer or Gas Fitter.

GENERAL NOTES

NOTES:

- These installation and operating instructions should be kept in a safe place. Should you require another copy, download from the **Warmington** website www.warmington.co.nz
- This appliance must be installed in accordance with the manufacturer's written instructions to comply with the **Warmington** warranty.
- The appliance and flue system must be installed in accordance with relevant standards and the appropriate building codes.
- This appliance must be serviced annually and any service operation must be carried out by a qualified service person.

WARNINGS:

- **WARNING; ANY MODIFICATION OF THE APPLIANCE THAT HAS NOT BEEN APPROVED IN WRITING BY THE TESTING AUTHORITY IS CONSIDERED A BREACH OF NZ STANDARDS.**
- **WARNING; DO NOT USE OR STORE FLAMMABLE LIQUIDS OR AEROSOLS IN THE VICINITY OF THIS APPLIANCE WHILST IN OPERATION.**
- **WARNING; DO NOT PLACE FLAMMABLE MATERIALS ON OR AGAINST THIS APPLIANCE.**
- **CAUTION:** THIS APPLIANCE SHOULD BE MAINTAINED AND OPERATED AT ALL TIMES IN ACCORDANCE WITH THESE INSTRUCTIONS.
- **CAUTION:** ALL SERVICING MUST BE CARRIED OUT BY AN AUTHORISED SERVICE TECHNICIAN.
- **CAUTION:** MAKE SURE THE USE OF CORRECT FUEL TYPE WITH THIS APPLIANCE.

NOTE: Keep a copy of these instructions for operating and maintenance guidelines.



Industries 1994 LTD
PO Box 58652, Botany 2163, Auckland www.warmington.co.nz