

SG & EG 780-900-1100 FSS Twin

FREESTANDING SQUARE - Open Gas Fire Installation Instructions

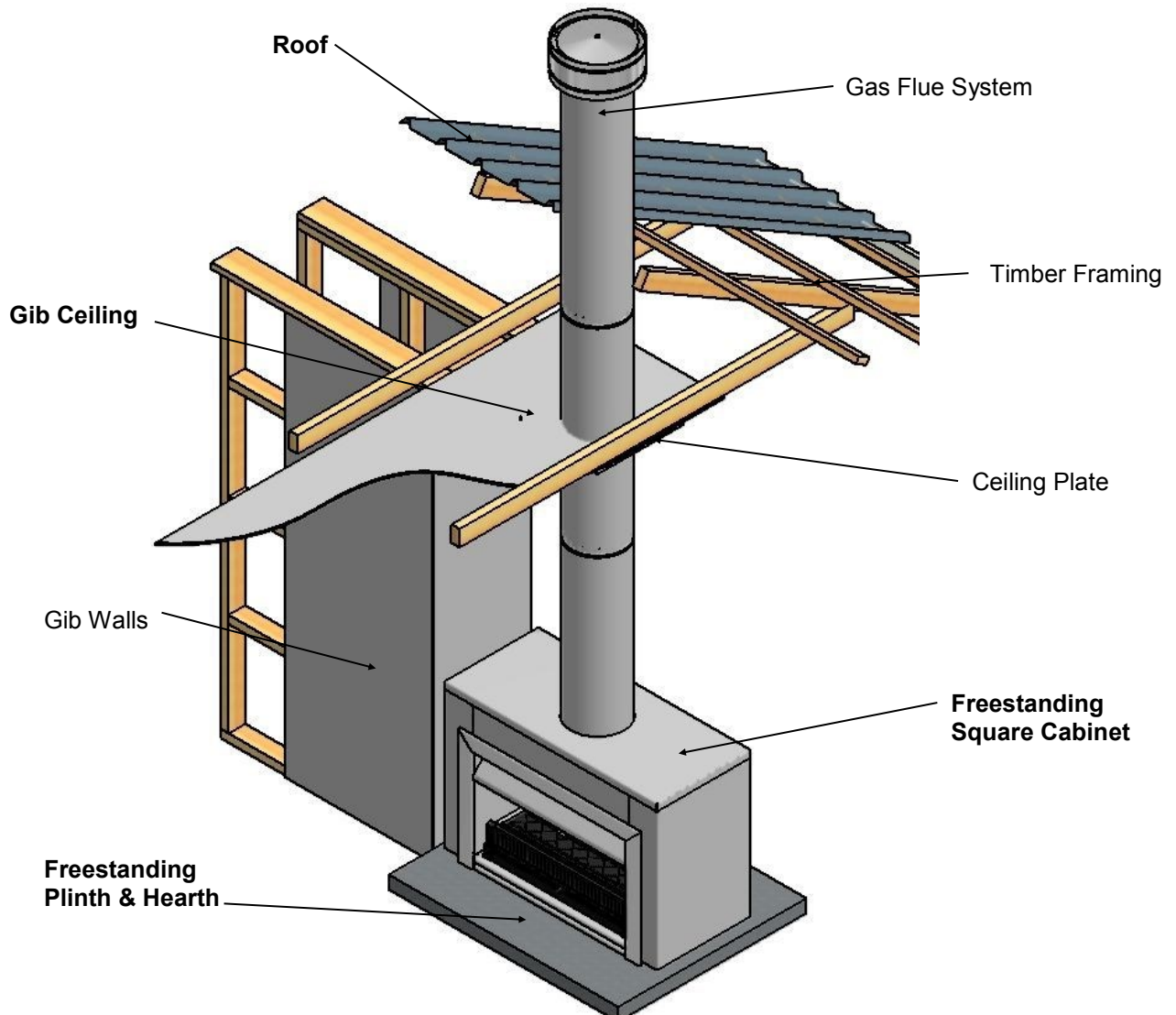

Related documents

Fire and flue system installation, and instructions to comply with NZS 5601.1:2013, 3645.1(Int):2010, 3645.2(Int):2010, 5266:2014, 2918:2001.

The fireplace is constructed and tested to comply with NZS 4558(int):2013 “Decorative gas log and other fuel effect appliances”.

Keep these instructions for further reference. Ensure that you have the correct and current installation details for the Warmington fireplace.

Installation

The Warmington unit is to be installed by a certified Warmington installer or an approved NZHHA installation technician.

See www.homeheat.co.nz/members for a certified NZHHA SFAIT Installer in your area.

A licenced certified gas fitter and licenced electrician are required to run power and gas supplies as required to the unit and any commissioning as part of the installation process. The heater must be installed according to these instructions and in compliance with all relevant building, gas fitting, electrical and other statutory regulations.

IMPORTANT

Read all the instructions carefully before commencing the Installation. Failure to follow these instructions may result in a fire hazard and void the warranty

Due to continued product improvement, Warmington Ind LTD reserves the right to change product specifications without prior notification.

POINTS TO CONSIDER PRIOR TO INSTALLATION

Location of the Fire. Open Fires are better located at one end of a room or area, as they project the heat away from their opening .

Venting to the Cavity.

This air is to allow the Cavity to Vent the Warm Air. This Warm Air helps keep the Fire and Flue System form getting to Cold . If the Flue and Fire get to Cold the System may soot often and require cleaning. Each Fire has different ways of venting the cavity .

The Topography of the Land .

The slope and position of the Land in relation to the Home has a bearing on how the wind will interact with the Fire and Flue System. Care needs to be taken to ensure that the Flue Termination is in the correct position to maximise performance .

The Prevailing Wind.

Care needs to be taken to ensure that the Flue Termination is in the correct position as wind and gusts that hits the Flue and Cowl System may overcome the Cowl and draft back down the Flue into the Home. This can be a combination of down draft and high pressure.

Hearth and Plinth:

The height of the Hearth off the Floor. The Finishing that is to be used on the hearth is to be allowed for at the design stage.

Positioning of the Flue System:

There is a maximum distance that an Offset Flue can be Installed. Reference to relevant standards..

Flue and Fire Clearance:

To be maintained to the Manufactures Instructions.

Pressure Differential, Venting & External Air into the Building :

All fires need air to burn and draw correctly, Kitchen Fans, Air Conditioning units, High Wind Zones, Naturally forming Draft spaces, can all have an effect on the pressure difference from inside the building to the outside. A lower pressure in the building may induce a draft down the flue system and back into the building causing the fire to smoke or spill into the building. **Care needs to be taken at the design and installation stage to adequately vent the building, or some mechanical system to ensure that there is always a neutral or positive pressure at the fireplace and a negative pressure at the flue outlet.** This will ensure that the draft in the flue system is always to the outside.

“CAITEC AIR” the limits and requirements. See details in these Spec’s, on www.warmington.co.nz or contact your local Agent.

Wind Noise:

You may encounter wind noise in some installations. It is recommended to use an enclosed chase with a chimney pot to help reduce noise. There will always be some noise from the flue systems of all fireplaces.

INSTALLATION ORDER OF OPERATIONS

Prior to Construction and Installation

Important Notes:

1. **Consult a licenced certified gas fitter for correct gas installation.**
2. Install to current standards.
3. Install to manufacture’s specifications.
4. All New Installations require a permit.
5. Allow for gas supply to heat cell at R.H. rear, and power supply to L.H. rear if required (check product).
6. For special requirements concerning materials (Timber Mantle and Surrounds) within close proximity of Warmington products, please contact your local Warmington Technical Consultant .
- 7.

Stage 1: **Frame Construction Procedure by Builder.**

1. Mark out Flue Centre.
2. Mark out Heat Cell Clearance requirements.
3. Mark out Flue Centre on ceiling for the Installation of the Freestanding Flue System.
4. Construct Plinth only, to required height. *

Stage 2: **Install Procedure by Certified “Warmington Installer”only.**

1. Fit Freestanding Fire to Plinth.(Ensure Gas Supply Line is fed through R.H. Side of Firebox.) Check Product for location .
2. Fit Freestanding Flue System.
3. Fit Gas Cowl and Flashing System.
4. Fit Weir Vents/Vents (if required), to cool the Chimney Chase Cavity and ensure efficiency of CAITEC Technology. (see Product & Spec)
5. Clean and touch paint up on the fires and cover if necessary.

Stage 3: **Finishing Procedure by Builder.**

1. Construct Hearth to required thickness. *
2. Close in Chimney Chase.
3. Finish Heat Cell Alcove and Hearth to customer’s requirements (e.g. paint / tiles).
4. *** Note: Certified Installer can Install Hearth and Plinth.**

Maintenance.

Visually Inspect Fireplace and Flue System.
Ensure that Firebox is operated according to the Manufacture’s Instructions.

Due to continued product improvement, Warmington Ind LTD reserves the right to change product specifications without prior notification.

WARMINGTON FREESTANDING FIREBOX DIMENSION

| Freestanding Firebox | | SG/EG 780 Twin | SG/EG 900 Twin | SG/EG 1100 Twin |
|------------------------|---|----------------|----------------|-----------------|
| Cabinet Width | A | 1210 | 1330 | 1530 |
| Cabinet Height | B | 855 | 855 | 855 |
| Cabinet Depth | C | 546 | 546 | 546 |
| Fascia Width | D | 940 | 1065 | 1260 |
| Fascia Height | E | 680 | 680 | 680 |
| Centre of Flue | F | 273 | 273 | 273 |
| Flue | G | 200 | 250 | 250 |
| Flue Outer Liner | H | 250 | 300 | 300 |
| Minimum Ceiling Height | K | 1700 | 1700 | 1700 |
| Fascia Section Width | L | 80 | 80 | 80 |

| Minimum Flue Height | |
|------------------------------|----------|
| Flue Height | 3600 |
| Measured From Top of Firebox | B + 3600 |

Seismic Restraint
Secure Firebox through anchor positions provided, (Through Base of Fire).

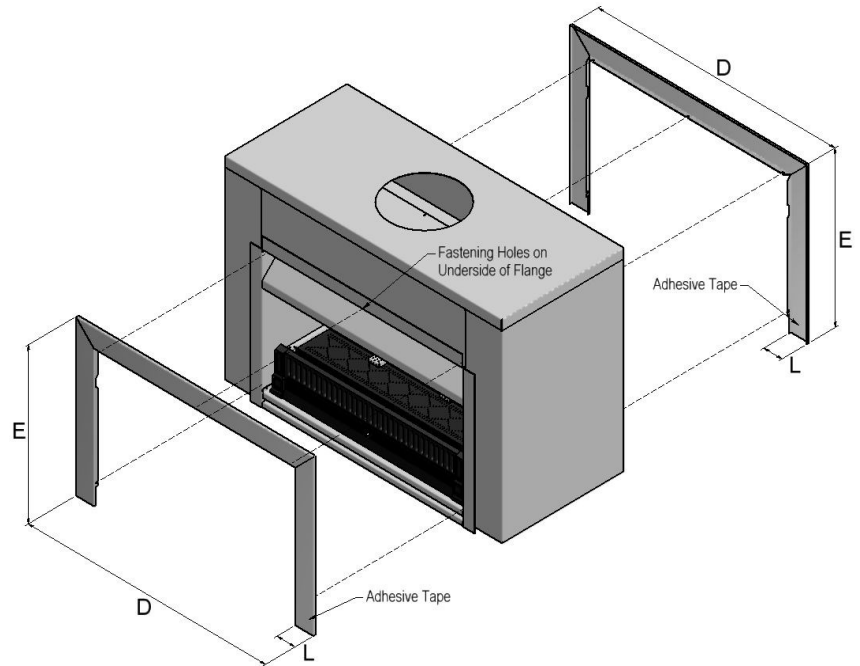
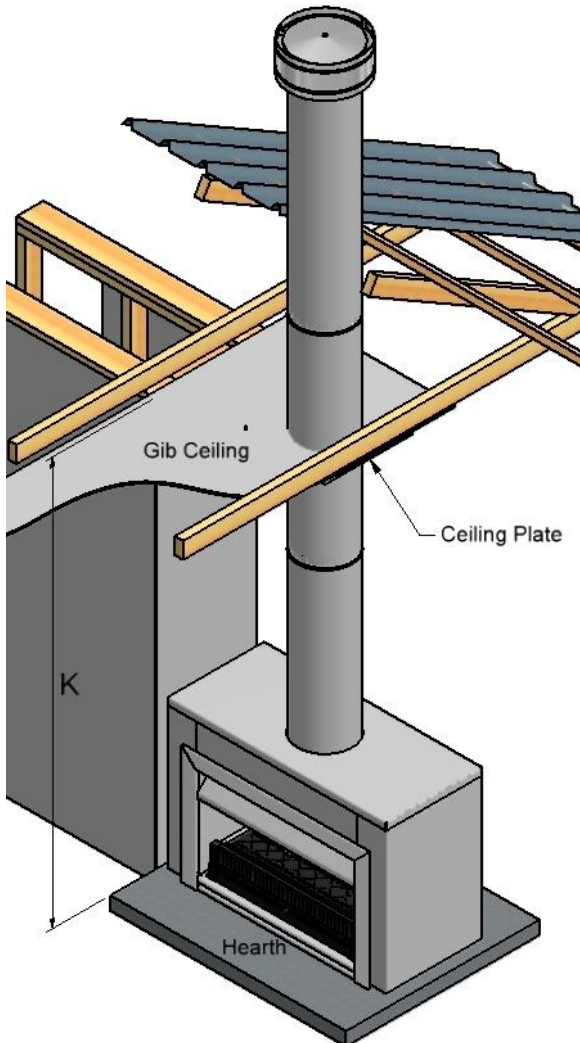
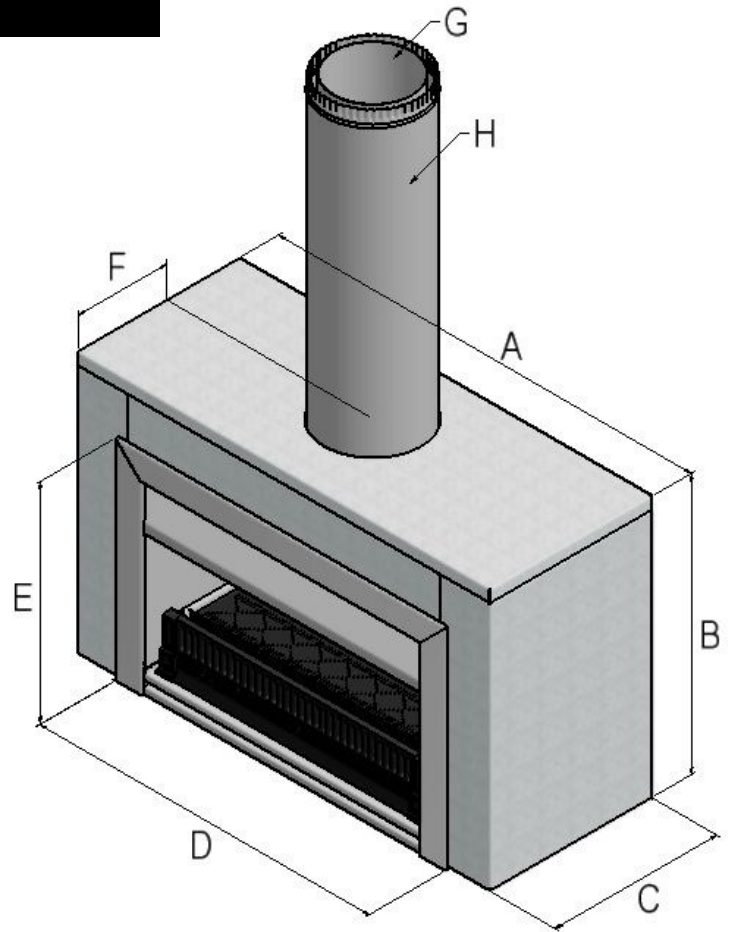

Due to continued product improvement, Warmington Ind LTD reserves the right to change product specifications without prior notification.

IMPORTANT NOTES :

GAS SPECIFICATIONS Tested to current gas standards

NOTE : All Test Pressures are tested by a Independent Test Lab * Inlet Pressure not to exceed 4.0kPa

| MODLE | SG-EG 780 Twin | SG-EG 900 Twin | SG-EG 1100 Twin |
|--------------------------|----------------|----------------|-----------------|
| LPG | | | |
| Nominal Pressure kPa | 2.75 kPa | 2.75 kPa | 2.75 kPa |
| Nominal Injector Size mm | 4 X 1.1mm | 4 X 1.2mm | 4 X 1.3mm |
| Max Supply Pressure kPa | 3.0 | 3.0 | 3.0 |
| Min Supply Pressure kPa | 2.5 | 2.5 | 2.5 |
| Burner Pressure High kPa | 2.5 | 2.5 | 2.3 |
| Burner Pressure Low kPa | 0.75 | 0.75 | 0.75 |
| MJ/h | 59 | 72 | 76 |
| Flame Effect Output Only | Effect | Effect | Effect |
| Supply Pipe Size dia—min | 1/2" | 1/2" | 1/2" |
| Natural Gas | | | |
| Nominal Pressure kPa | 1.5 kPa | 1.5 kPa | 2 kPa |
| Nominal Injector Size mm | 4 X 1.9mm | 4 X 2.2mm | 4 X 2.4mm |
| Max Supply Pressure kPa | 3.0 | 3.0 | 3.0 |
| Min Supply Pressure kPa | 1.0 | 1.0 | 1.5 |
| Burner Pressure High kPa | 0.85 | 0.6 | 0.5 |
| Burner Pressure Low kPa | 0.2 | 0.1 | 0.1 |
| MJ/h | 70 | 77 | 83 |
| Flame Effect Output Only | Effect | Effect | Effect |
| Supply Pipe Size dia—min | 1/2" | 1/2" | 1/2" |
| Lab. Test No | GL 939 | GL 945 | GL 931 |
| Lab. Test Dates | June 2010 | July 2010 | 30/05/2010 |
| ESS Declaration No: | | | |

SEISMIC RESTRIANTS

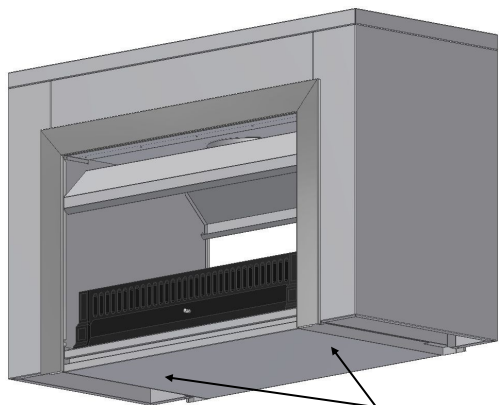

This is a Raised & cantilevered Hearth. See page 12 for further Raised Hearth Detail

Seismic Restraint
Secure Firebox through anchor points provided

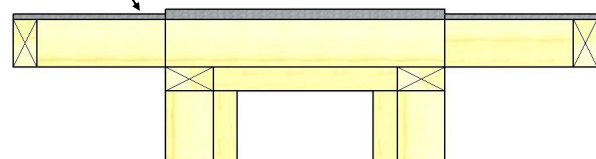

HEARTH & PLINTH CONSTRUCTION DETAILS

Note: Hearth and Plinth Construction.

Plinth to be Offset above Hearth by the Hearth Finishing's (e.g. Tiles / Granite / Solid Plaster / etc)

Raised Hearths & Plinth's with cantilevered Hearths must be adequately supported to take the weight in Accordance with the NZ Building Code .

* Hearth & Plinth Material must be built with Non Combustible Material eg. 9.5mm Promina, Superlux, Etapan.

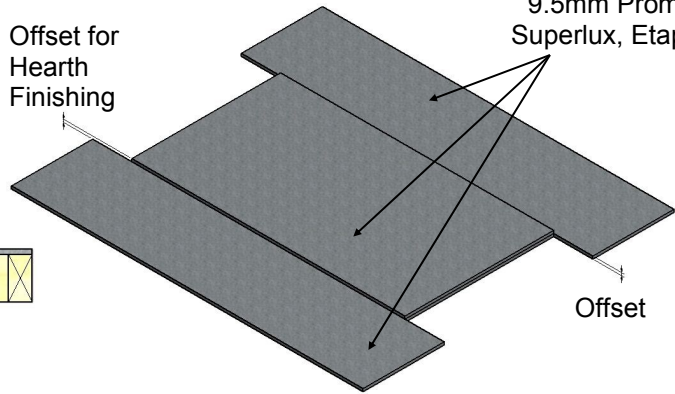

***Note: If Solid Plastering the Heat Cell structure, it is recommended to use a Fibreglass Mesh with a Latex Based Plaster to minimise the chance of the Solid Plaster cracking. (See your Solid Plasterer for correct materials and applications).**
Due to continued product improvement, Warmington Ind LTD reserves the right to change product specifications without prior notification.

PLAN VIEW OF CABINET CLEARANCES (STRAIGHT WALL HEARTH)

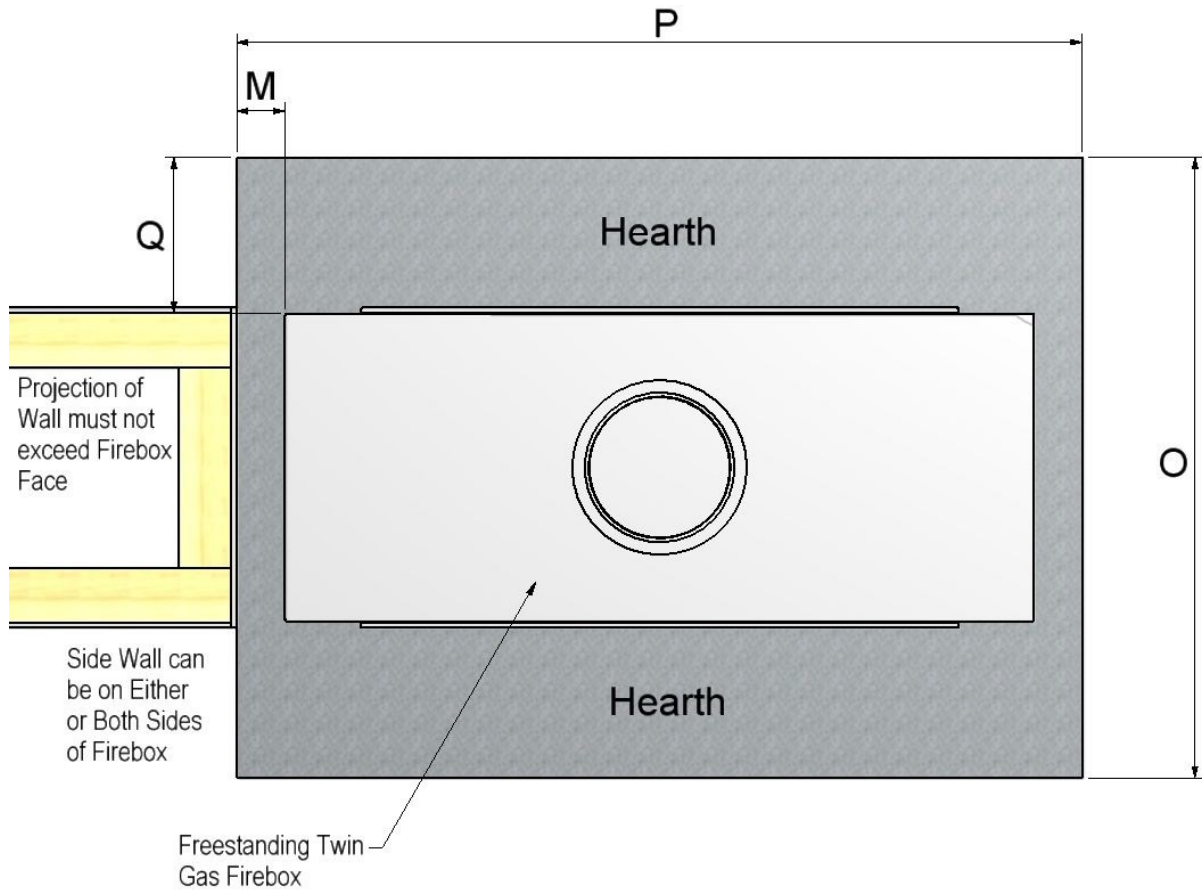

| Firebox | | SI 780 | SI 900 | SI 1100 |
|-------------------|---|-----------|-----------|------------|
| To Wall Side | M | 85 | 85 | 85 |
| Hearth Depth | O | 1146 | 1146 | 1146 |
| Hearth Width | P | 1380 | 1500 | 1700 |
| Hearth Projection | Q | 300 | 300 | 300 |

Note:
Hearth is to be constructed of Non Combustible Material .
Plinth under Firebox can be constructed of Framing .
Ensure Hearth Finishing's completed prior to Installation .

Due to continued product improvement, Warmington Ind LTD reserves the right to change product specifications without prior notification.

“Caitec” Wear Vent System (Concept Only)

“CAITEC” TECHONOLGY—ROOM AIR REPLACEMENT

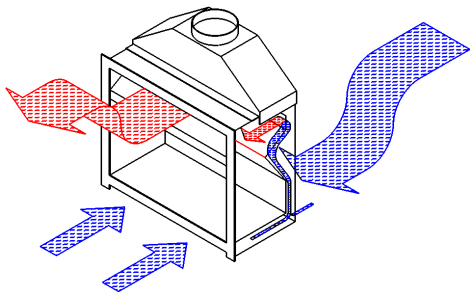

Caitec draws air from an External Air Source to ensure that Combustion Air that the Open Fire uses is replaced, maintaining the Home at a Constant Pressure Equilibrium, reducing the risk of Back Drafting. Ensure that the Home is vented to Outside Fresh Air. 2 x 100mm Diameter vent are required (Or equivalent to that.)
Builder to supply External Air to the “Warmington Fire” . (Not Supplied)

Concept Drawings Only

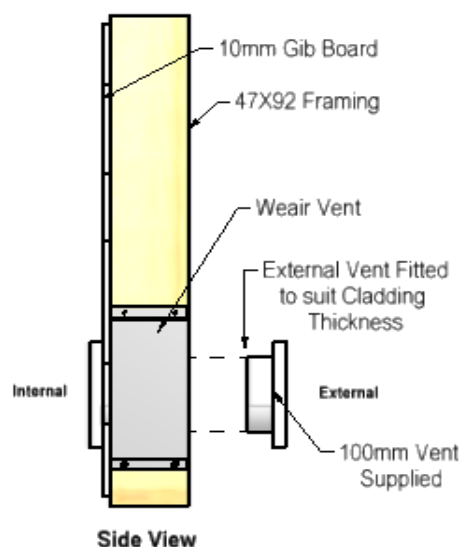
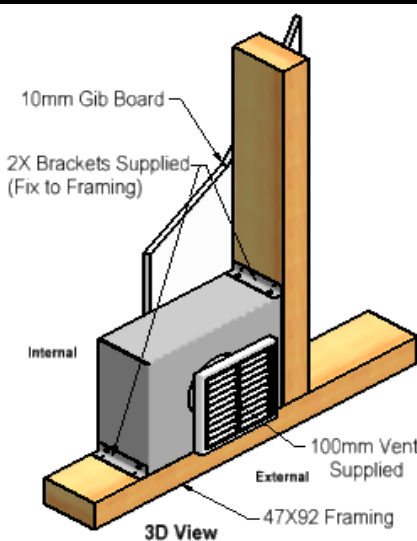
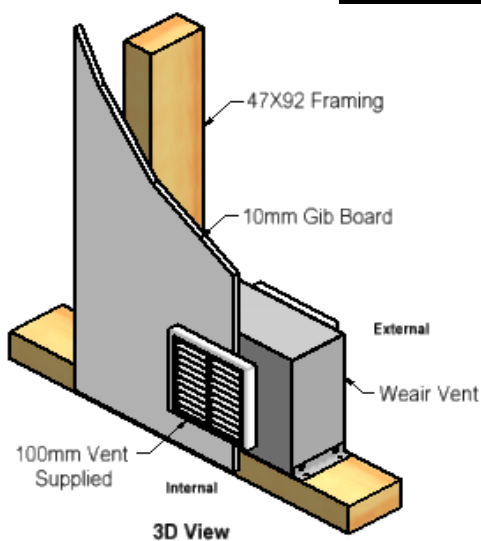

Side Section View

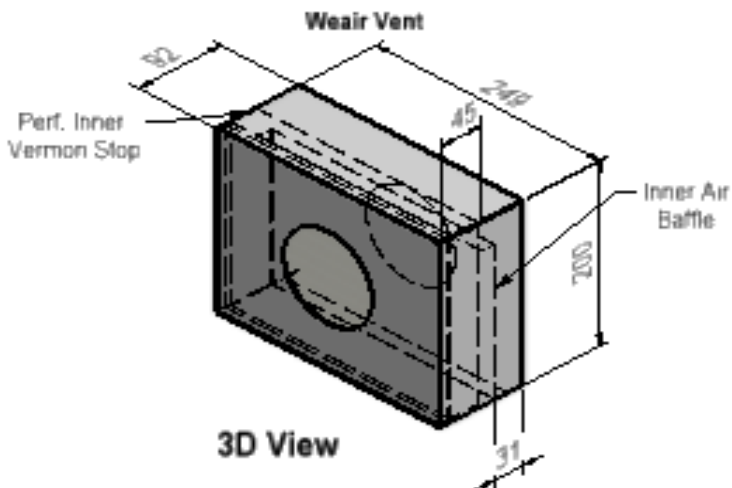
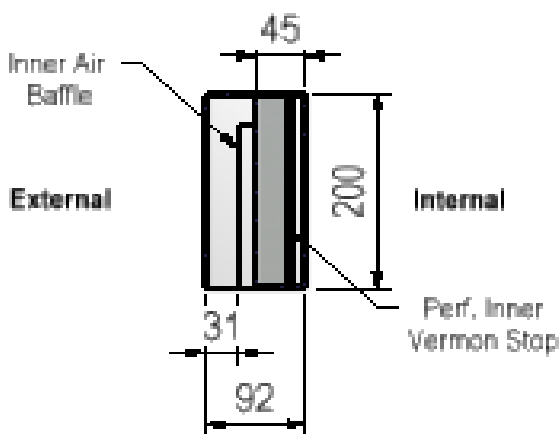

Important Note :
 For Optimum Performance place “Caitec” Wear Vent System as close to Fireplace as possible

Due to continued product improvement, Warmington Ind LTD reserves the right to change product specifications without prior notification.

FLUE DETAILS DIMENSIONS

| Flue details | No: | SG / EG | SG / EG | SG / EG |
|-------------------|-----|---------|---------|---------|
| | | 780 | 900 | 1100 |
| Cowl | 1 | 200 | 250 | 250 |
| Flue Diameter | 3 | 200 | 250 | 250 |
| Liner Diameter | 3 | 250 | 300 | 300 |
| Spacer | 3 | 200/250 | 250/300 | 300/300 |
| Bottom Spacer | 1 | 200/250 | 250/300 | 250/300 |
| Ceiling Plate | 1 | 250 | 300 | 300 |
| Ceramics & Screws | | 4 | 4 | 4 |

| Minimum Flue Height | |
|------------------------------|----------|
| Flue Height | 3600 |
| Measured From Top of Adaptor | B + 3600 |

NOTE:
Ensure that a Standard Tested Warmington Flue System is used on the Warmington Fires.

FLUE SYSTEM INSTALLATION GUIDE

This is a general installation guide only – Contact a “NZHHA Installer” or Gas Fitter for Installation Advice .

1. Install the first length of flue pipe with the crimped end down, inside the Adaptor collar, ensure that the flue pipe is sealed into the collar with exhaust sealant. Rivet the flue in 3 places around the Adaptor collar. Place a bottom spacer around the flue pipe approximately 150mm above the adaptor collar. Secure in position by tightening the screw and nut.
 2. Install the second length of flue pipe with the crimped end down and fit by riveting in at least 3 places around the flue pipe joint. Ensure that the flue is sealed into position with sealant.
 3. Install the first section of flue pipe liner with the Crimped end up, over the flue pipe and over the spacer that is fixed to the flue pipe. This spacer will keep the liner concentric about the flue pipe.
 4. Position flue spacer at the flue pipe joint for every length of “Flue pipe” and “Liner”.
- Repeat the Steps from 1 – 4 to the installed required height of the flue system. The flue system is to comply with the current standards.

- a “the flue pipe shall extend not less than 4.6m above the top of the floor protector.”
- b “ the minimum height of the flue system within 3 m distance from the highest point of the roof shall be 600mm above that point.”
- c “the minimum height of the flue system further than 3 m from the highest point of the roof shall be 1000mm above the roof penetration.”
- d “no part of any building lies in or above a circular area described by a horizontal radius of 3 m about the flue system exit.”

IF FLASHING CONE NEEDED

1. **NOTE:** The last length of flue pipe needs to extend past the liner so that when the “top spider” and the “Flashing cone” are fitted, that the “flashing cone” and the “flue pipe” are **flush**, or that the “flue pipe” is **5mm lower** than the “Flashing cone”.
2. Fit the “Top Spider” into position, ensure that the legs of the spider are fitted inside the liner and that the spider is positioned hard down onto the liner and tighten with the screw and nut.
3. Place the “Flashing cone” over the “flue pipe” and press hard down onto the “Top Spider”. (Note that the “Flue pipe” and the “Flashing Cone” are either flush or the “Flue pipe” is 5mm Lower than the “Flashing cone”.) Ensure that the “Flashing cone” is clear for the venting from the “Liner” and the “flue pipe”.
4. Fit the “Cowl” to the top of the flue pipe. The “Cowl”, “Flashing cone”, and the “Flue pipe” can be secured to each other with the uses of a stainless steel self tapping screw. This will allow the “Cowl” to be removed for cleaning.
5. Flue system may require Bird Proofing due to the installation and locations, discuss this with your installer for the best advice.
6. If the Flue system is installed into a “Chimney Chase”, allow for air vent as close to the top of the chase as practical, or allow venting through the “Chimney Chase Flashing”. A “Venting Flashing cone” and a 25mm gap around the Liner with a “Venting Flashing Cone-Spider” can be used. Ref : to Figuresin this specification.

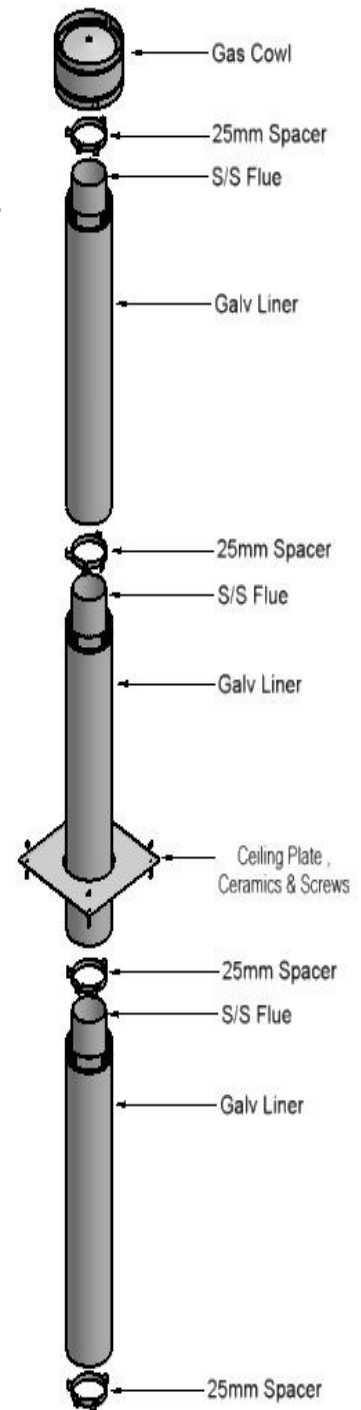

Due to continued product improvement, Warmington Ind LTD reserves the right to change product specifications without prior notification.

FLUE PENETRATION Vented through Alcove (Single lined Flue System)

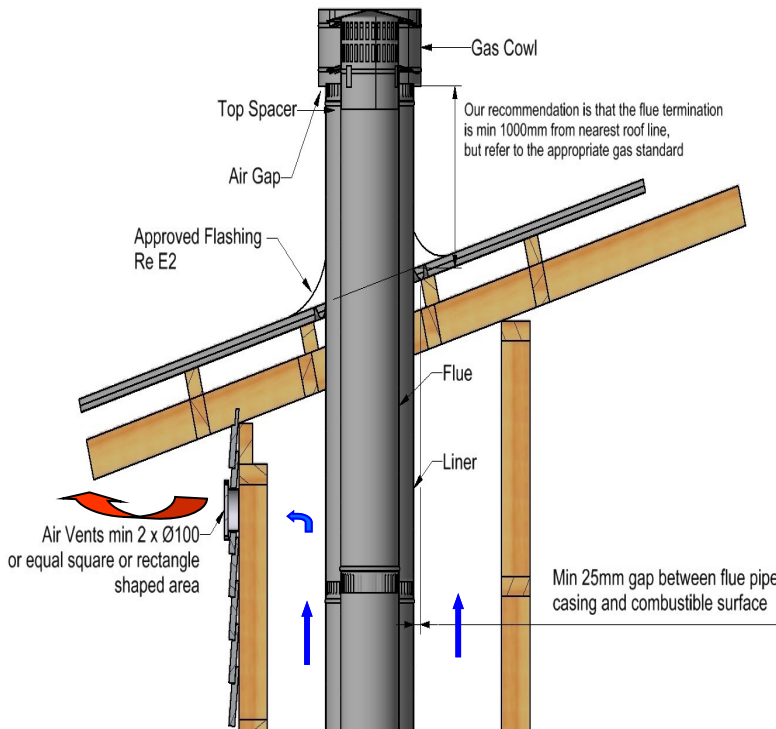

FLUE PENETRATION Vented through Alcove (Double lined Flue System)

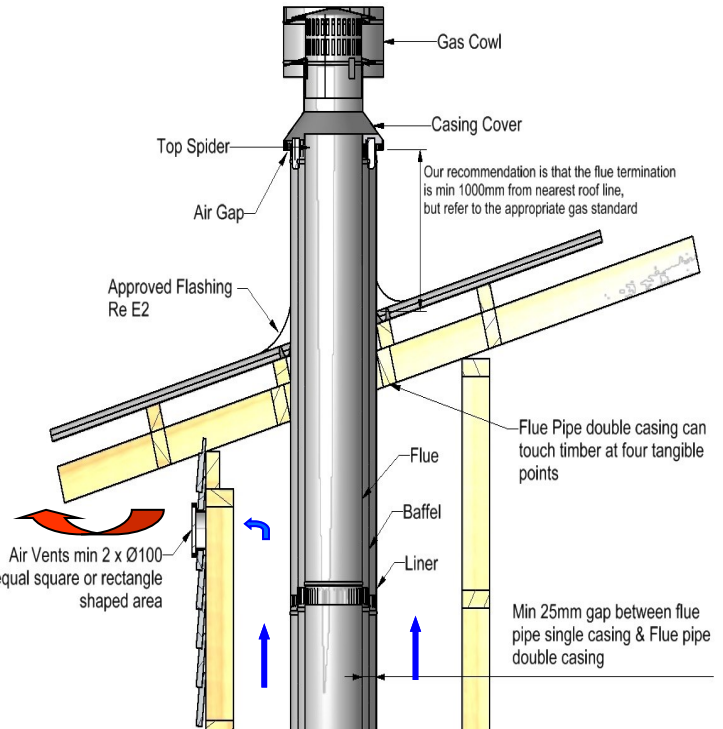

FLUE PENETRATION Vented through Top Flashing

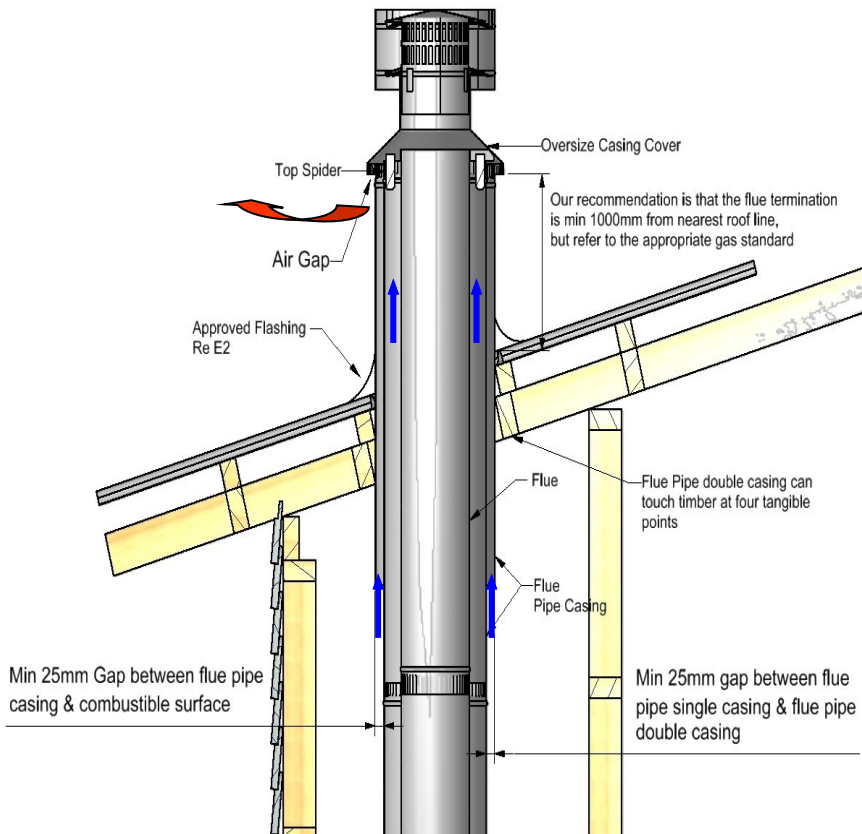

Note:

External requirements
Refer to relevant standards.

Install flue system to relevant standards.

When using a rubber or bitumen flashing (butynol, bectite) an additional flue pipe baffle is required.

All external air vents & ceiling penetrations must be bird proofed with permanently fixed screens.

All flashing to comply with E2.

All external air vents and ceiling penetrations are to be Vermin and Rodent proof.

| Test Report Number | Date of Report |
|--------------------|----------------------------|
| 04/1039 | 20 th July 2004 |
| 04/1040 | 20 th July 2004 |
| 04/1041 | 20 th July 2004 |

Due to continued product improvement, Warmington Ind LTD reserves the right to change product specifications without prior notification.

CHIMNEY CHASE FLASHING DETAILS

SETTING ADD GAS COWL HEIGHT

General Chimney Chase Flashing Lay Out

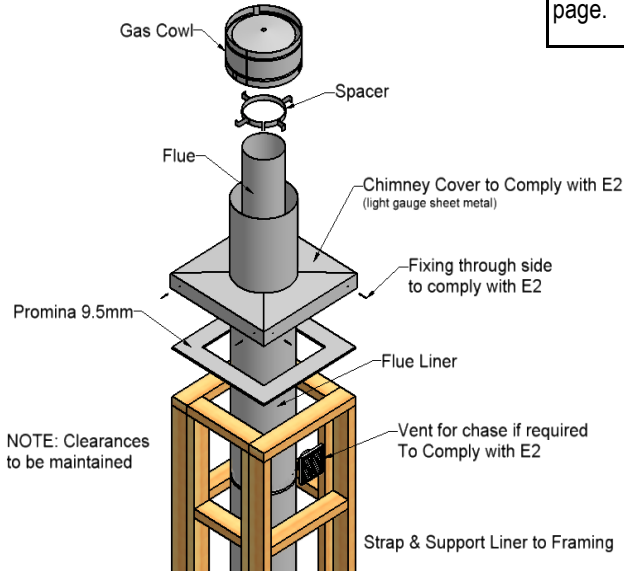

Note:
Flashing Spigot height is determined by the Insulation that is fitted under the Flashing ... See Details at bottom of page.

SETTING COWL to FLUE
ADD Gas Cowl is to be set as shown and is in accordance with Foley's Industries LTD.

STEP 1

Flues are to be set flush to the same height, Spacer set at approx 80mm low.

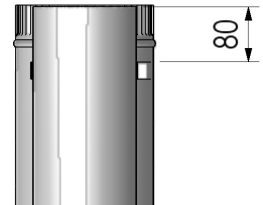

STEP 2

ADD Gas Cowl slides inside the flue, sitting on the swage, leaving a 10mm Air gap from cowl to liner, screw to secure

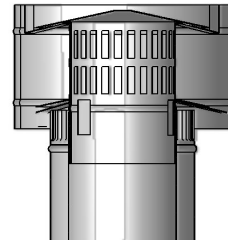

"CHIMNEY CHASE FLASHING" AND "AIR VENTILATION" OPTIONS :

VENTING THROUGH CHIMNEY CHASE

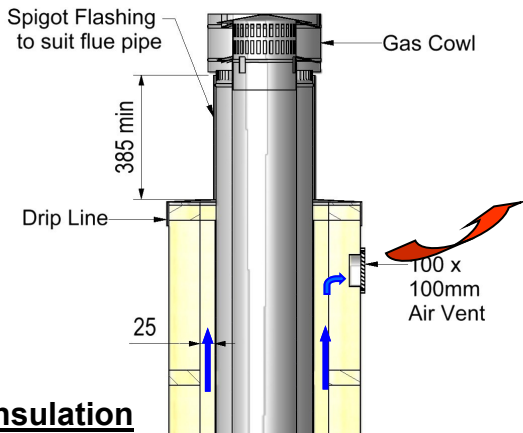

Note : 2 X 100MM VENTS in chase.

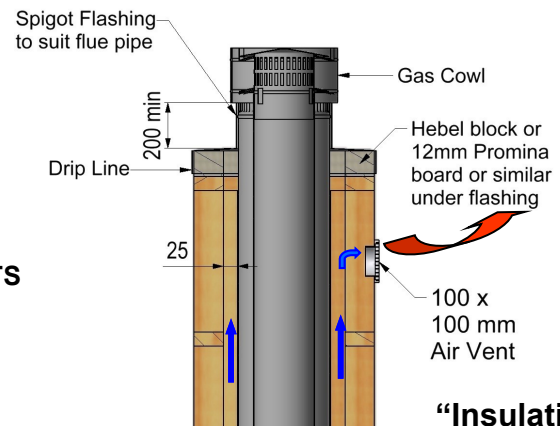

"Insulation under flashing"

"No Insulation under flashing"

VENTING THROUGH FLASHING

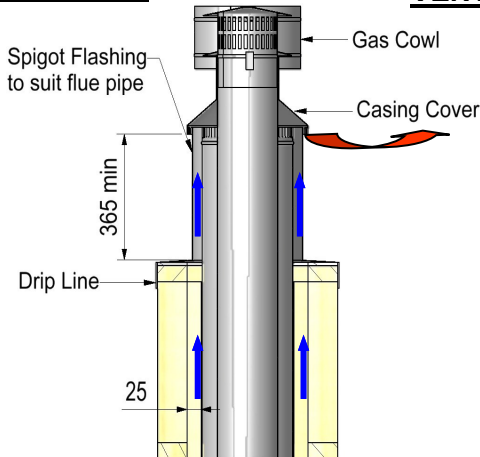

Note : 2 X 100MM VENTS in chase.

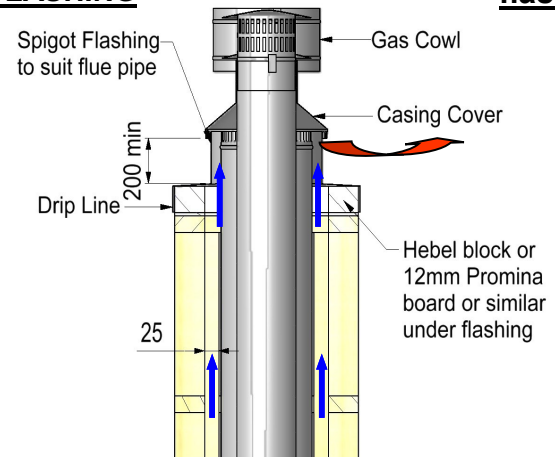

Due to continued product improvement, Warmington Ind LTD reserves the right to change product specifications without prior notification.

FLUE HEIGHT MINIMUM DETAILS

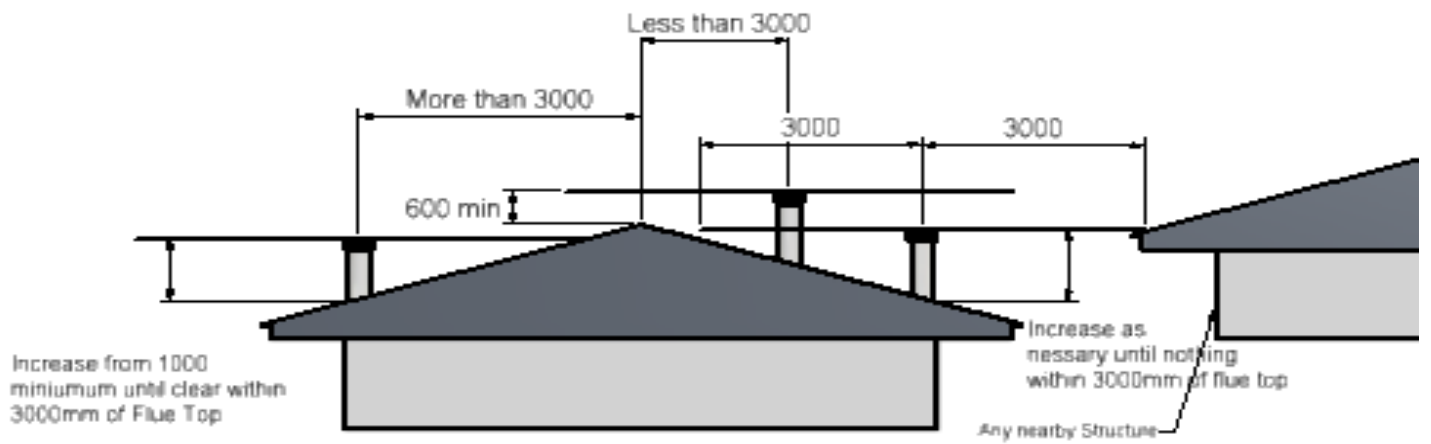

The Flue exit is to Comply to relevant standards.

3D View

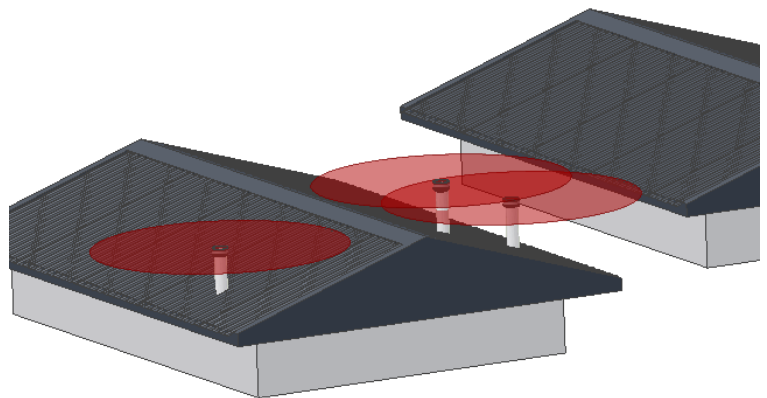

FRAME OUT AND TRIM OUT DETAILS FOR CHIMNEY CHASE

Option X – Singled Lined Flue System

Option Y – Double Lined Flue System

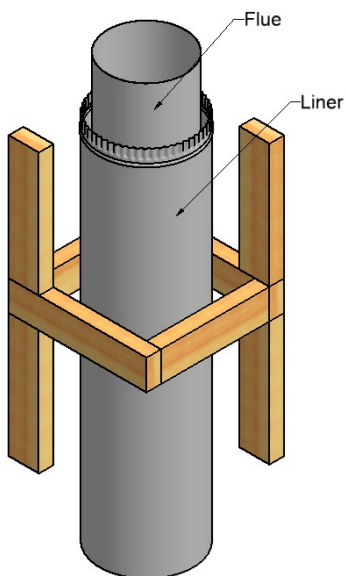

$$X = \text{Liner Diameter} + 50 \text{ mm}$$

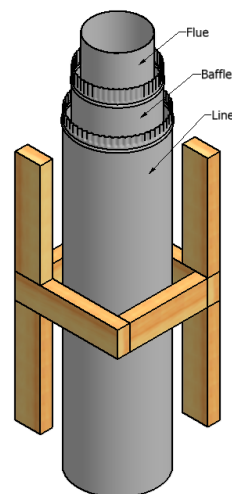
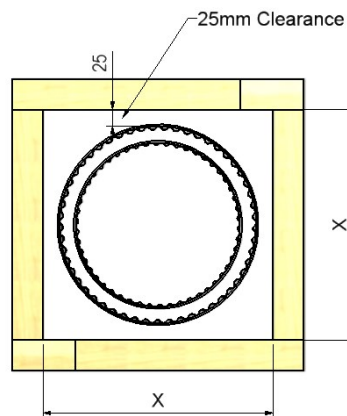

$$Y = \text{Liner Diameter}$$

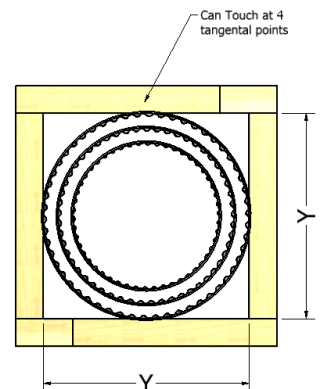

Due to continued product improvement, Warmington Ind LTD reserves the right to change product specifications without prior notification.

PLAN VIEW OF SIDE WALL PROJECTION INSTALL CLEARANCES

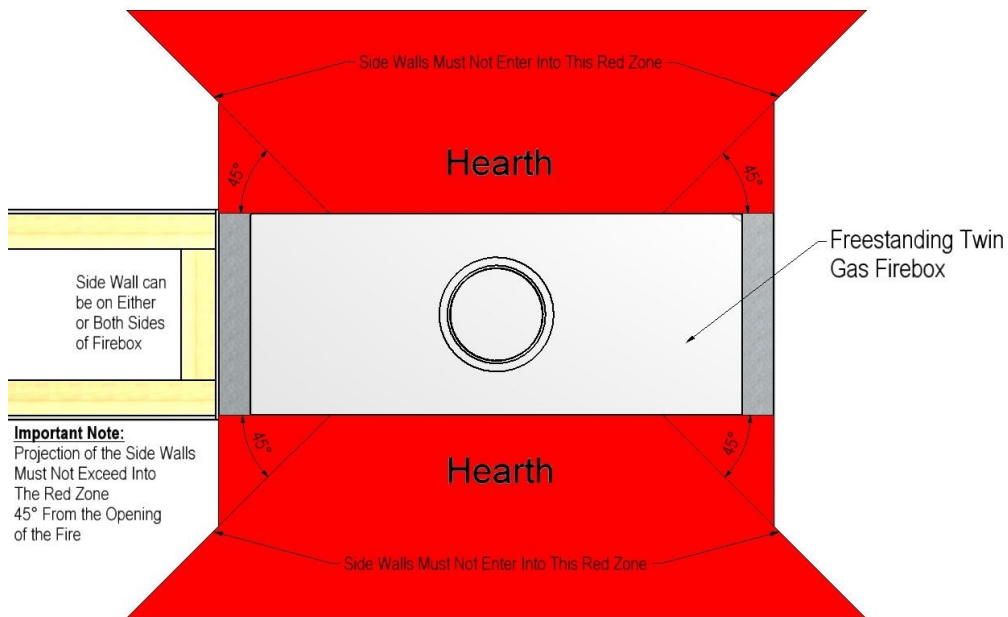

Important Note:
Side Wall Projection Must Not Exceed Into the Red Zone at 45° From the Opening of the Fire & Required Hearth Dimensions

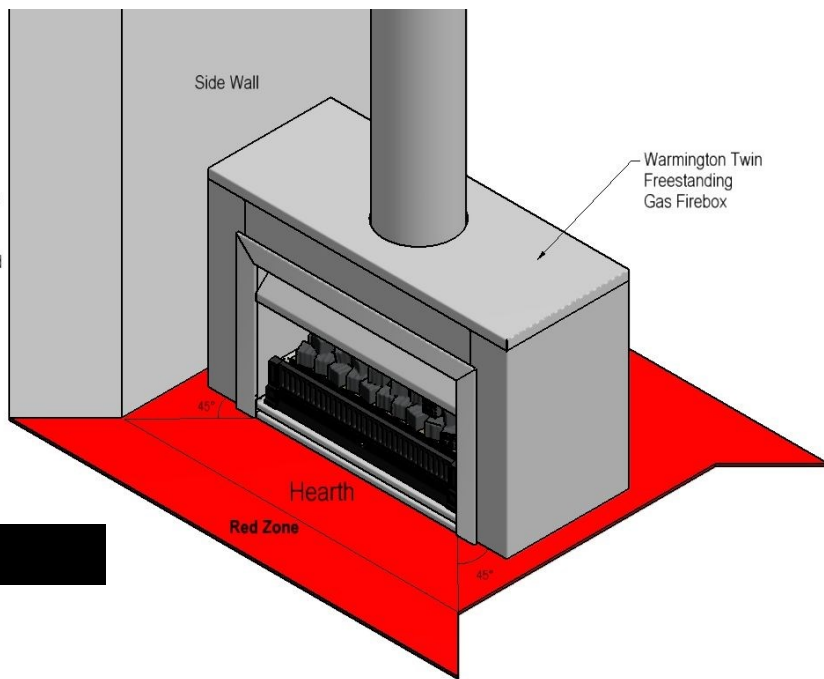

RAISED HEARTH CLEARANCES

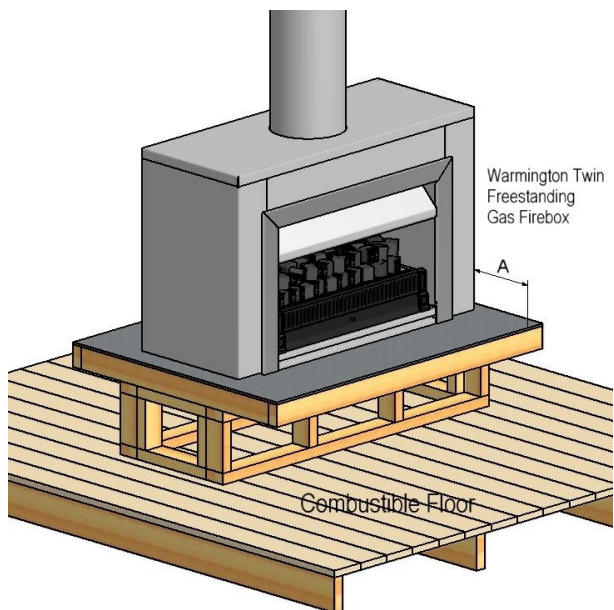

Note: For Combustible Floors

Minimum Hearth of 300mm (A) must be maintained at any given height.

Due to continued product improvement, Warmington Ind LTD reserves the right to change product specifications without prior notification.

TO THE INSTALLER / GAS FITTER and ELECTRICIAN

SG / EG Range: Gas Convection Fireplaces

NOTES:

- Service annually or more if required.
- Custom built to clients requirements to relevant and current standards.
- The appliance and flue system must be installed in accordance with the relevant and current standards and the appropriate building codes.
- The appliance and flue system must be tested in accordance with the relevant and current standards and the appropriate building codes.

FLUED GAS APPLIANCES All Gas Fires requiring Warmington Flue Systems shall be Installed to the requirements of the current standards and shall be appropriately designed and constructed to permit safe and effective use. This Appliance must be flued to the outside atmosphere. All Warmington Fires must be Installed with a **minimum of 3.6m** of Approved **Warmington Gas Flue and Liners** .

GAS TYPE All Gas Fires shall operate safely on the Gas Type specified on the Appliance and shall comply with the requirements of The Gas Act 1992 .

APPLIANCE SAFETY Any Gas Fire Appliance shall comply with the safety requirements of the current standards listed under “ Related documents” in this specification.

ELECTRICAL REQUIREMENTS All Gas Fire Appliances Installed with Mains Supplied Electrical components for associated use with these Appliances, must comply with The Electricity Regulations 1993.

ELECTRONIC CONTROL SYSTEMS Any Gas Fire Appliance Installed with Manual or Programmable Electronic Control System shall be tested and/or approved by a Recognised Person or Authority.

SEISMIC RESTRAINTS All Fires used for Domestic and Commercial Purposes shall be firmly secured (unless defined as portable or mobile) to prevent dislodgement from their point of fixture or Installation during Seismic Activity. Such Restraint must be of a reasonable expectation .

GAS CONNECTION

A Gas Certificate must be obtained for the Installation and Commissioning of this Appliance and Flue System .

Check that the Gas Type Specified on the Data Plate is correct for the available supply (LPG or NG).

A Copper Gas supply capable of supplying the correct MJ/h , should be brought into the rear of the Installation Cavity through the hole provided . A Flare Nut is provided on the Burner for Gas Connection to the Appliance .

COMMISSIONING AND TESTING OF FIREPLACE (To be carried out by Gasfitter)

Read all the instructions before commissioning. Install coals and logs and burner before commission.

Light appliance and check HIGH/LOW settings. Check operation of appliance and adjust to suit.

Adjust control valve setting if required. After a period of running (30min Plus) check the setting of the pilot and adjust if required. See Spec's for details.

Extinguish appliance, remove test equipment and secure test nipple. Check for Gas Leaks.

Note* The Control Valves are factory set and should not require adjustment.

GAS FITTER TO CARRY OUT STANDARD TESTING FOR COMMISSION:

- Spill test taken at top of opening with smoke or smoke match.
- Leak testing appliance and joints.
- Correct operation of the burner and coal and log lay out.
- Test gas pressures high and low, drop test on supply line.
- 5 second light time across burner, Other testing that may be required.
- Ventilation requirements to the standards.
- Clean and or touch up paint of fire box and burner
- Hand over to client, tests and comply to relevant standards.

FITMENT OF BURNER



Gas Supply Pipe into Fire , by Gasfitter . See Spec's for Pipe Sizes .

Burner may be secured To the Firebox (Optional)

Due to continued product improvement, Warmington Ind LTD reserves the right to change product specifications without prior notification.

VERMICULITE (COURSE) (To be set by Gasfitter)

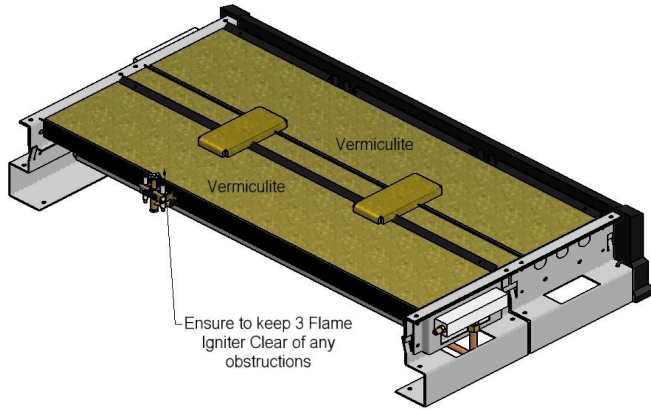

General Coal orientation fro optimum effect.

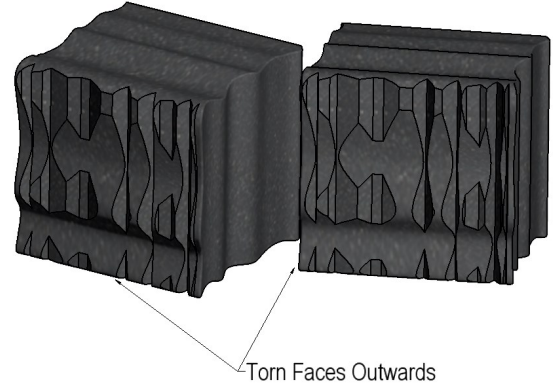

APPLYING THE VERMICULITE : (Course—must be larger than the burner plates holes so not to block them)

Apply with care a thin layer of Vermiculite over the Burner , just enough to cover the Burner Tray only .

NOTE: If the burner flame is uneven, the Vermiculite may need to be changed or sifted to remove the smaller pieces that can block the burners holes. The smaller pieces can ,cause uneven burn and the unit to run dirty.

COALS AND LOGS (To be set by Gasfitter)

Gloves should be worn when handling Ceramic Fibre Coals & Logs : care needs to be taken when handling Coals & Logs , Due to the Carbon on the Coals can stain the surroundings.

HELPFUL HINTS : When Hot use Metal Tonges.

Apply a thin layer of Vermiculite over the Burner , just enough to cover the Burner Tray only as shown above.

1 : Bottom Row : Assemble 2 Bottom Rows of Coals onto the Vermiculite Base . **2 : Top Row :** Assemble 2 Top Rows of Coals onto the Bot-
tom Row .

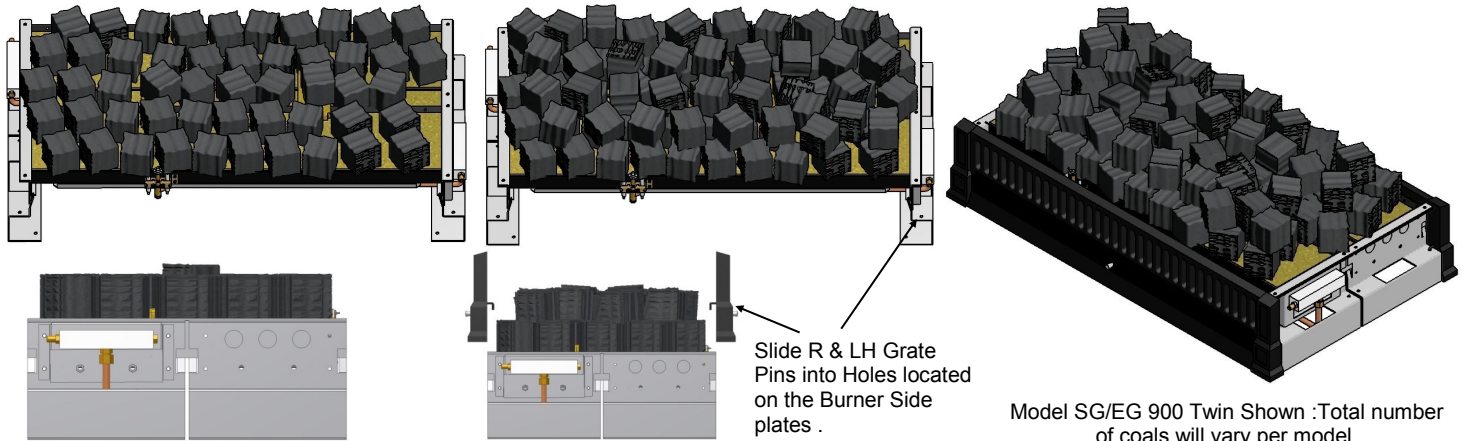

1 : Bottom Row

2 : Top Row

Each Coal randomly positioned with the Torn (roughest) Face Outward . **Ensure Coal positioning does not directly block the 3 Flame Pilot .**

The placement of the Coals & Logs may vary to make an even Flame Pattern .

Logs and Twigs may be scattered to achieve best Visual Effect .

| Model | Number of Coals per Row | | Number of Rows | | Total Coals |
|-----------------|-------------------------|-----|----------------|-----|-------------|
| | Bottom | Top | Bottom | Top | |
| SG/EG 780 Twin | 8 | 7 | 5 | 4 | 68 |
| SG/EG 900 Twin | 10 | 9 | 5 | 4 | 86 |
| SG/EG 1100 Twin | 12 | 11 | 5 | 4 | 104 |

Due to continued product improvement, Warmington Ind LTD reserves the right to change product specifications without prior notification.

FASCIA KIT (Black or Stainless Steel)

- Locate the three self-tapping screws provided into the under-side of the top ledge of the firebox
- Remove the backing tape from the adhesive Velcro pads at the bottom of each fascia side
- Offer the fascia into position locating the three screws into their associated slots - tighten screws
- Apply firm pressure to the bottom edges to bond the Velcro tape
- The fascia may be removed at any time by loosening the screws and parting the Velcro

Please refer to additional sheet for Burner Ratings and Frame-out details.

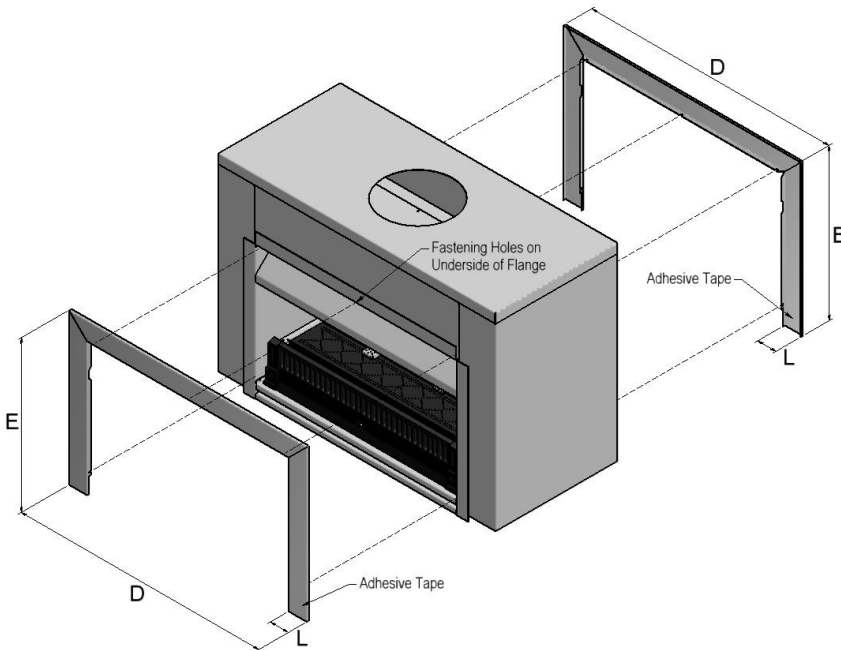

Note:
Fascia is fitted at the end of the installation process and may be after the wall and surroundings have been completed.

OPERATION OF YOUR WARMINGTON GAS CONVECTION FIRE (SG ONLY)

Your Fire must be Installed and Tested by a suitably qualified Gasfitter prior to use.

To light :

- Open the front cover by pulling in outwards.
- Push in the ignition switch and hold in the 'PILOT' position for 5-10 seconds until you can hear the gas come through the pipe - making sure the ignition switch is pressed in firmly.
- To strike the igniter, turn anti clockwise to the * STAR position (with the ignition switch still firmly pressed in) until you hear the pilot ignite with a 'click'. Repeat this process 2 or 3 times if necessary.
- Once the pilot flame is lit, hold this position for 3-5 seconds, then gently let the ignition switch out, and set the flame control to high. It may take a few seconds for the burner to light all the way across.
- Once the flame is established, adjust to the desired setting and close the cover.

To shut down :

- Open the cover by pulling it outwards.
- Turn the control ignition switch to 'PILOT' and the flame bed will extinguish.
- Pilot light may be left on and the pilot flame will still burn.
- To fully extinguish, turn to the 'OFF' position before closing the COVER.



Due to continued product improvement, Warmington Ind LTD reserves the right to change product specifications without prior notification.

ADJUSTMENT OF HI—LOW PRESSURE (Only to be Adjusted by Gasfitter)

Adjustment of High & Low Settings Must be Carried out by a Certified Gas Fitter Only .

Note* Control Valves are Factory Set but may require adjustment onsite .

Turn Appliance Off & Remove Front Plastic Cover on Igniter , Pull Cover to Slide off .

Unscrew Test Nipple on the Burner Manifold & fit the Test Gauge Securely - See Diagram

* To Set the High : Light the Burner & turn to High - Then Adjust the High Screw to the Desired Pressure . See Spec's

* To Set the Low : Light the Burner & turn to Low - Then Adjust the Low Screw to the Desired Pressure . See Spec's

Extinguish Appliance, remove Test Equipment and Secure Test Nipple .

* Check Valve & Burner for Correct Operation & check Fire for Gas Leaks .

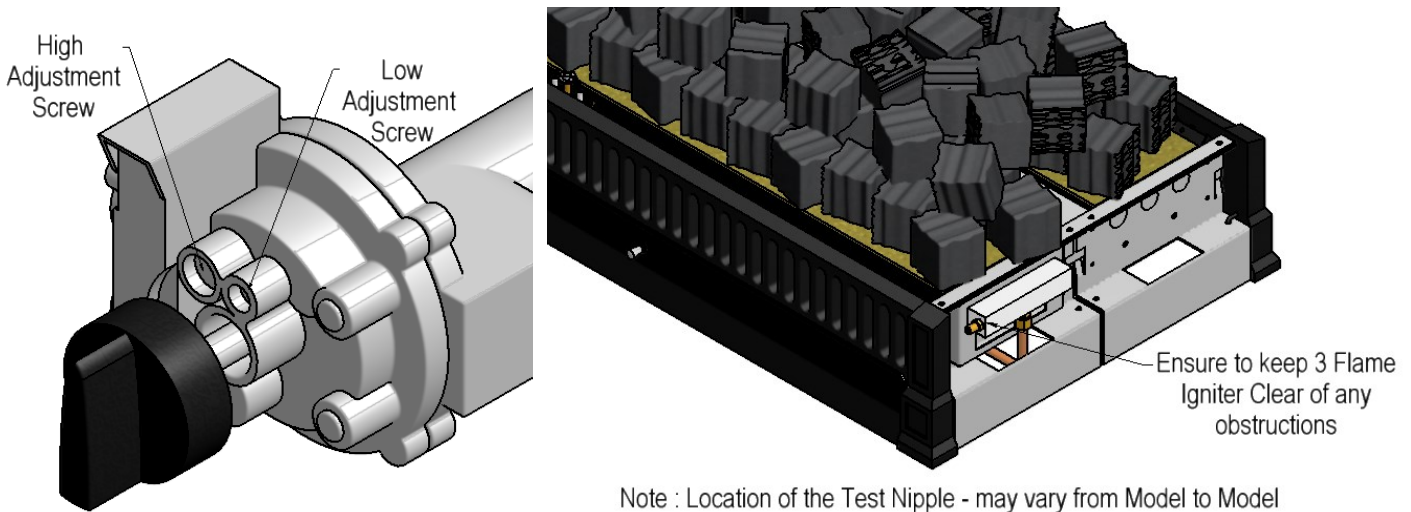

Note : Location of the Test Nipple - may vary from Model to Model

ADJUSTMENT OF THE PILOT—3 FLAME (Only to be Adjusted by Gasfitter)

Note: When the Base screw is removed, gas will leak from the out let, ensure that the pilot is not adjusted or the screw is removed when the fire is burning.

- Adjustment of Pilot - 3 Flame : Unscrew Base Screw as shown in Diagram 2 .
- Insert a Screw Driver as shown in Diagram 3 and adjust the Adjustment Screw up inside the 3 Flame Pilot to adjust the Flame Height .
- The Flame must always be passing over the Electrodes &/or File Tube on either side .
- Replace the Base screw and check for leaks.

Note: to Gas Fitters

The 3 flame pilot may need adjustment after a period of running time on set up as the increase in heat in the fire will induce a higher draft in the fire, and may pull in flame away from the File Tube causing the fire to shut down.

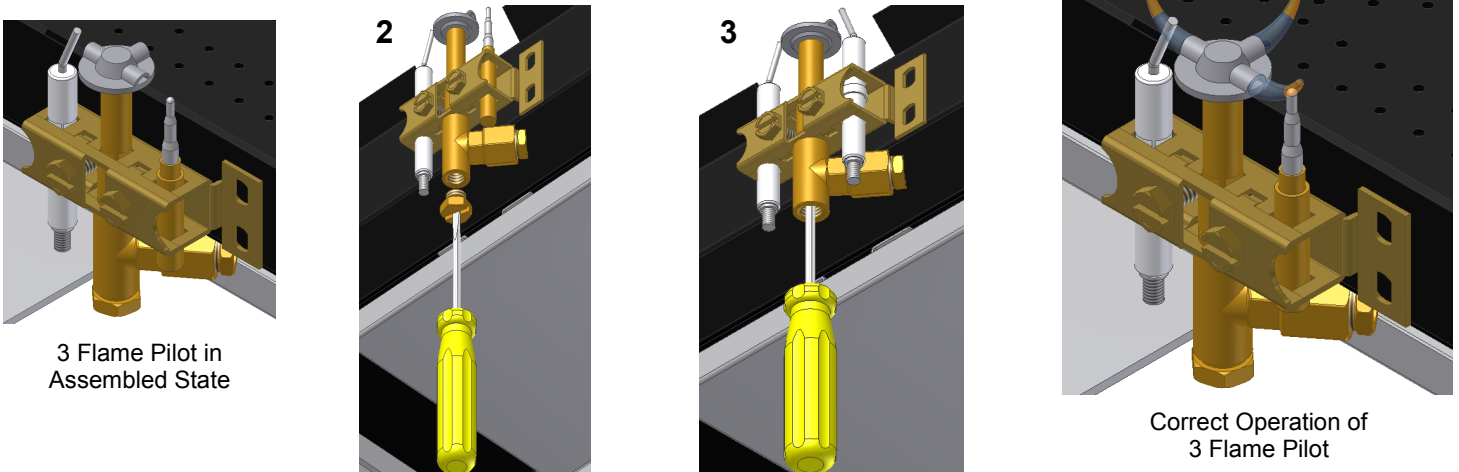

Due to continued product improvement, Warmington Ind LTD reserves the right to change product specifications without prior notification.

POINTS OF SAFETY—To the Customer /Home-Owner

Your Warmington Gas Decorative Fire operates on the principle of dual radiant and convected heat. Therefore it is important to observe the following precautions associated with any heating appliance or open fire.

- Do not cover or restrict the fireplace upper or lower vents in any way as this may result in a build-up of hazardous gases within the room.
- The fire is not intended for the drying of clothing, bedding etc.
- Avoid installing this appliance in high traffic areas, strong draughts or near drapes or furniture.
- The use of an approved fireguard is recommended for the protection of young children.
- Avoid using aerosols when the appliance is operating.
- Avoid anyone leaning against or lying directly in front of the fire while operating.
- Do not place anything objects into or against the gas fire at any stage.
- The fire may release a small amount of smoke on its first start up which may take 1 or 2 hours to dissipate . This is part of the curing process so ensure there is adequate ventilation within the room.
- Always use a registered Gas Fitter or Electrician for installing and maintenance work
- Always use certified gas cylinders that have been tested and are safe to use.
- Never modify your gas appliance or its settings from those specified by the manufacturer.

APPLIANCE SAFETY Any gas fire appliance shall comply with the safety requirements of the current standards listed under “Related documents” in this specification.

ELECTRONIC CONTROL SYSTEMS Any gas fire appliance fitted with manual or programmable electronic control systems shall be tested and/or approved by a recognised person or authority.

SEISMIC RESTRAINTS All gas fires used for domestic and commercial purposes shall be firmly secured (unless defined as portable or mobile) to prevent dislodgement from their point of fixture or installation during seismic activity. Such restraint

WHAT DO YOU DO IF YOU SMELL GAS

Open windows and doors

Do not light any gas appliance

Do not use any electrical appliance or switches

Do not use the telephone in your home

Leave the building; shut off the domestic gas supply valve (beside your meter)

Call your gas supplier/gas fitter or the Fire Service for further advice.

MAINTENANCE : All burner setting, Coals placement, Vermiculite is to be checked and set in accordance with this specification by the service person/Gas fitter

**Lighting your gas fire using electronic or remote ignition systems may vary as per manufacturer instructions*

Warmington Industries recommend annual servicing of your gas fire by an approved Gas Fitter.

External surfaces should be dusted with a damp, lint-free cloth when the fire is cold.

Warmington Industries provide 12 months warranty from the date of purchase, for domestic or commercial installations

This Warranty Covers :

Replacement Parts and Labour for Gas Control Components due to Manufacturing Defects Only.

Repair or Replacement of the Burner or Firebox Components due to Manufacturing Defects Only.

Warranty cover will be considered void if the product is subject to incorrect installation, failure to operate the appliance in accordance with the supplied instructions and specifications or is subject to damage or misuse beyond the expected conditions of normal use.

All installations and servicing must be carried out by and approved Warmington dealer or Gas Fitter.

Due to continued product improvement, Warmington Ind LTD reserves the right to change product specifications without prior notification.

OPERATION OF YOUR E.G GAS BURNER IGNITER ONLY

FOR MANUAL OPERATION OF YOUR EG WARMINGTON DECORATIVE FIRE

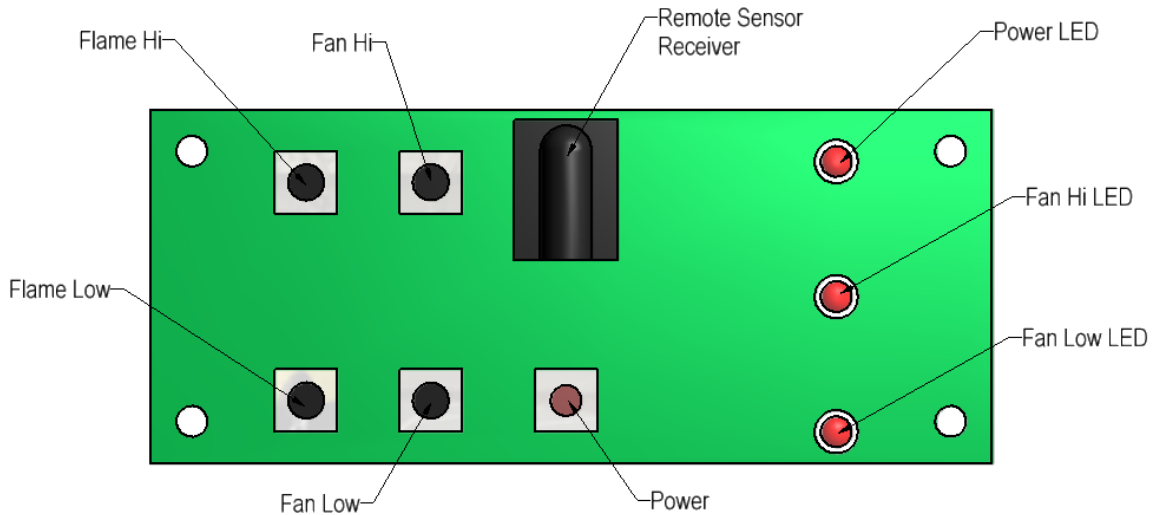

AS SHOWN FROM THE FRONT OF THE BURNER.

This Control Panel is Located on the Bottom Left Hand Side of your Warmington decorative Gas Fire.

Press and Release the Power Button. This will Start the Electronic Spark and the Power LED will be on Permanently . The Pilot will Ignite First, once this is on, it will ignite the Main Burner. Pressing and Releasing the Power Button again will Switch Off the Appliance.

When the Appliance is Turned On again, the Gas Fire will resume the previous Flame and Fan settings , unless the Appliance was Switched Off due to Power Failure. In the circumstance of a Power Failure the Remote Control System will return to the default settings which is a Low Flame and the Fan Turned Off.

If the Gas Fails to light, the Appliance it will go into Lock Out Mode , after trying to ignite for 1 minute (approx.) . In Lock Out Mode the Power LED will remain illuminated. To start the Appliance again Press and Release the Power Button Twice after the Gas Supply Resumes.

FLAME OPERATION

Press and Hold the + button to Increase the Main Burner Flame . Press and Hold the - button to Decrease the Main Burner Flame. By holding the + or - Flame Button for up to 10-15 sec this will Increase or Decrease the Main Burner Flame to it's Max or Min .

Due to continued product improvement, Warmington Ind LTD reserves the right to change product specifications without prior notification.

FAN OPERATION

This Warmington Decorative Gas Fire has a 3 Speed Fan and its operated independent from the Main Burner.

This is done by pressing and releasing the fan + or – button will Increase or Decrease the Fan Speed. The LED on the Front Panel will indicate the Fan Settings at Low, Medium, or High Speed.

Pressing and Releasing of the button will Lower the Speed until the Fan is Turned Off .

REMOTE CONTROL FEATURES

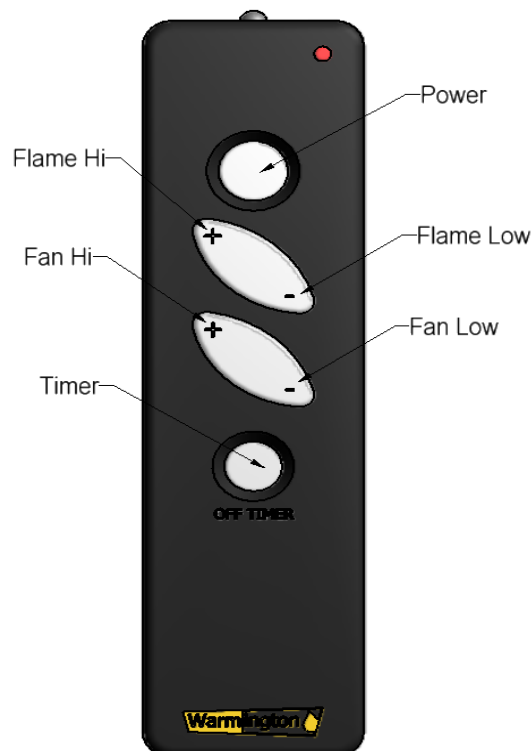

Your Remote Control has all the features of the Control Receiver situated on the Front Panel of the Burner .

By pressing Timer Button , the Power LED will start flashing and after 30 minutes the appliance will Shut Off Automatically .

By pressing the Timer Button again within the 30 minute period, this will reset the Timer and the power LED will Stop Flashing .

IMPORTANT NOTE ABOUT YOUR DECORATIVE FIRE

Warranty Cover will be considered void if failure to operate the appliance in accordance with the supplied Instructions and Specifications, or is subject to damage or misuse beyond the expected conditions of normal use which could result in injury or property damage .

PROCEDURE FOR THE TEST AND COMISSIONING OF YOUR DECORATIVE FIRE.

Ensure Gas Supply and the Power Supply (caution 240V) to the Unit.

- Refer to Data Plate on this Specification for settings. The Data Plate is attached to the under carriage of the Burner .
- Remove Front Grate ensure the CAT5 cable to the Control Receiver is still connected.
- Loosen the Jet Test point and attach manometer (Digital is preferred). The Test Point is on the Right Hand Side of the Gas Burner , as Shown Below .

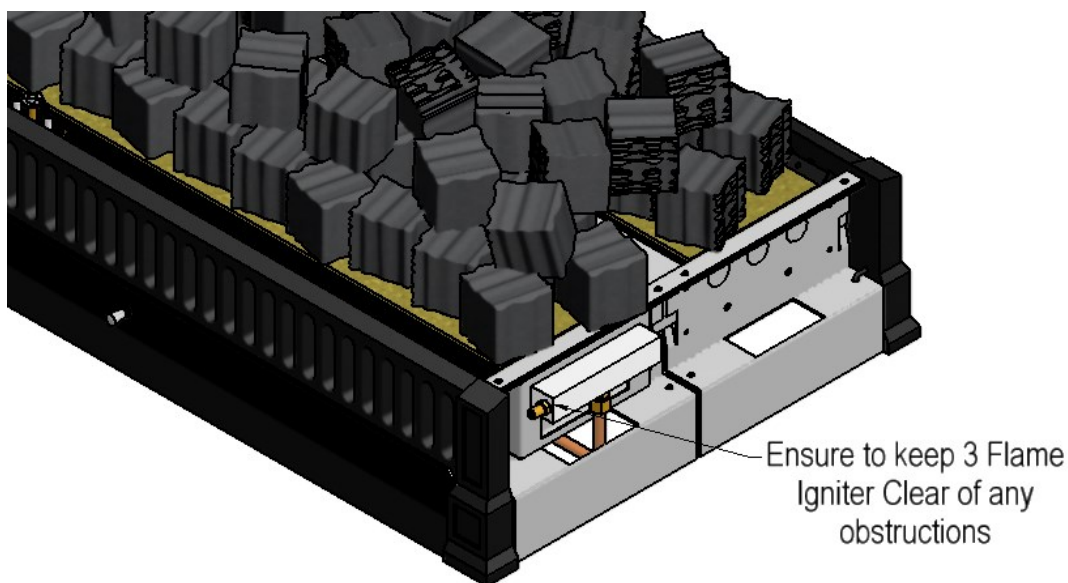

Note : Location of the Test Nipple - may vary from Model to Model

- Light Appliance, adjust to High Flame setting and check pressure, adjust to Low Flame and check pressure.

NOTE : If setting the Pressure is required it is to be carried out by a Certified Gas Fitter.

- If adjustments are necessary, remove the cap . The Pressure Adjustment Screw and Nut are on the Front Side of the Gas Control Valve (shown in Diagram B in this specification) and are **Factory** set.

High Pressure Setting: Set the modulator to Maximum Condition. Screw in **Nut A** to Increase the Outlet Pressure then screw Nut A out to Decrease the Pressure to the desired settings . Use 10mm spanner.

Low Pressure Setting: Turn Off the Power to the Modulator (by disconnecting the **Modulator Harness Connection** at the Valve - See Wiring Diagram in Page 17 .) and, keep Nut A stationary . Use a screwdriver to screw in **Screw B** to Increase the Pressure and Screw it Out to Decrease the Pressure . Carefully replace the Modulator Plastic Cap .

WARNING: To ensure the Correct Operation of the Modulator it is necessary that the Plastic Cap is returned to its original location .

Due to continued product improvement, Warmington Ind LTD reserves the right to change product specifications without prior notification.

DIAGRAM B (SHOWING CONTROL VALVE WITH TEST POINTS AND ADJUSTING SCREW).

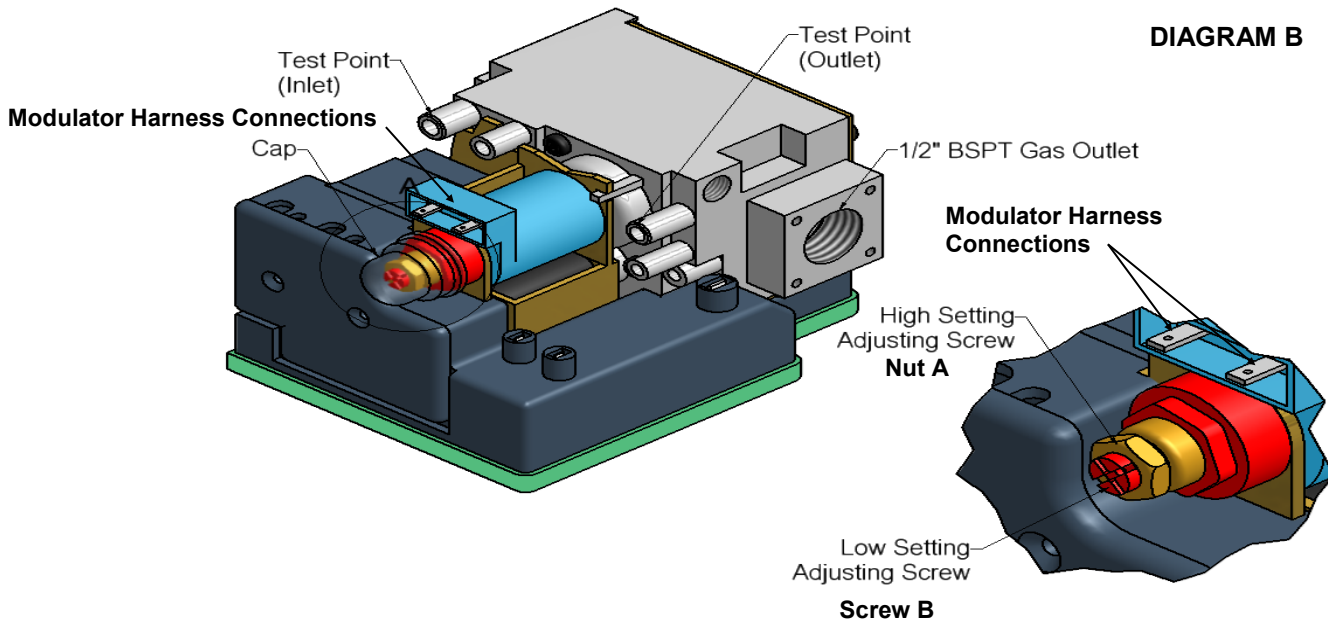

- After checking the pressure, turn the unit off, remove Manometer from the Test Point and Tighten the Test Point Screw. Ensure to check for gas leaks.
- Ensure Power is Off & Reconnect Modulator Harness Connection in the Main Harness. See Diagram B Above .
- Turn the Appliance On and Off a few times to check ignition.
- When you are satisfied that the Appliance is working correctly , fit the Front Panel Assembly back to the Gas Burner.
- NOTE : Ensure you peel the Protective Plastic Coating from any Stainless Steel components if fitted.
- All Burner Aerations are Factory Preset and cannot be adjusted.
- If you are unable to get the unit to operate correctly, refer to troubleshooting before contacting your Local Service Contact as listed.
- It may take approximately 2 hours of operation for the coals/Logs or river rocks to achieve their full flame pattern and glow.
- During the Initial Burning in period, some smoke and smell may be experienced , the appliance should be run on the high position in a well ventilated room until these dissipate .

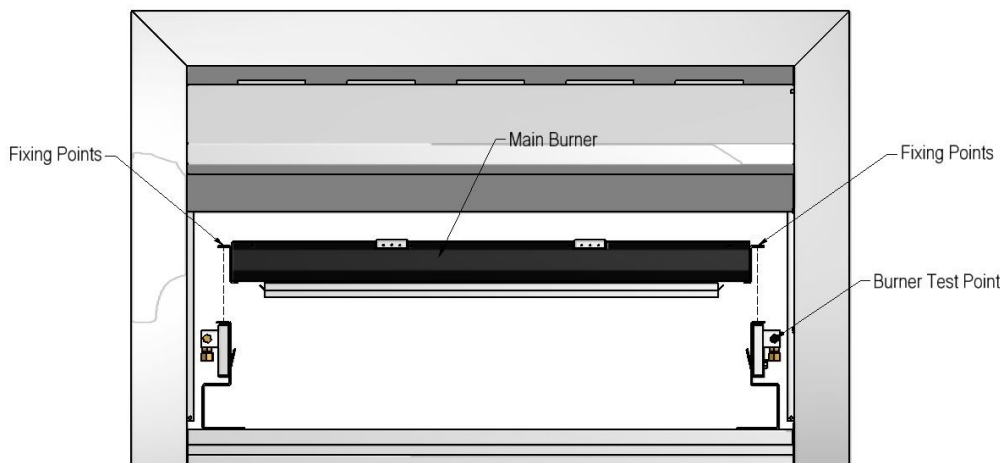

Due to continued product improvement, Warmington Ind LTD reserves the right to change product specifications without prior notification.

REMOTE IGNITION EG GAS FIRE WIRING DIAGRAM

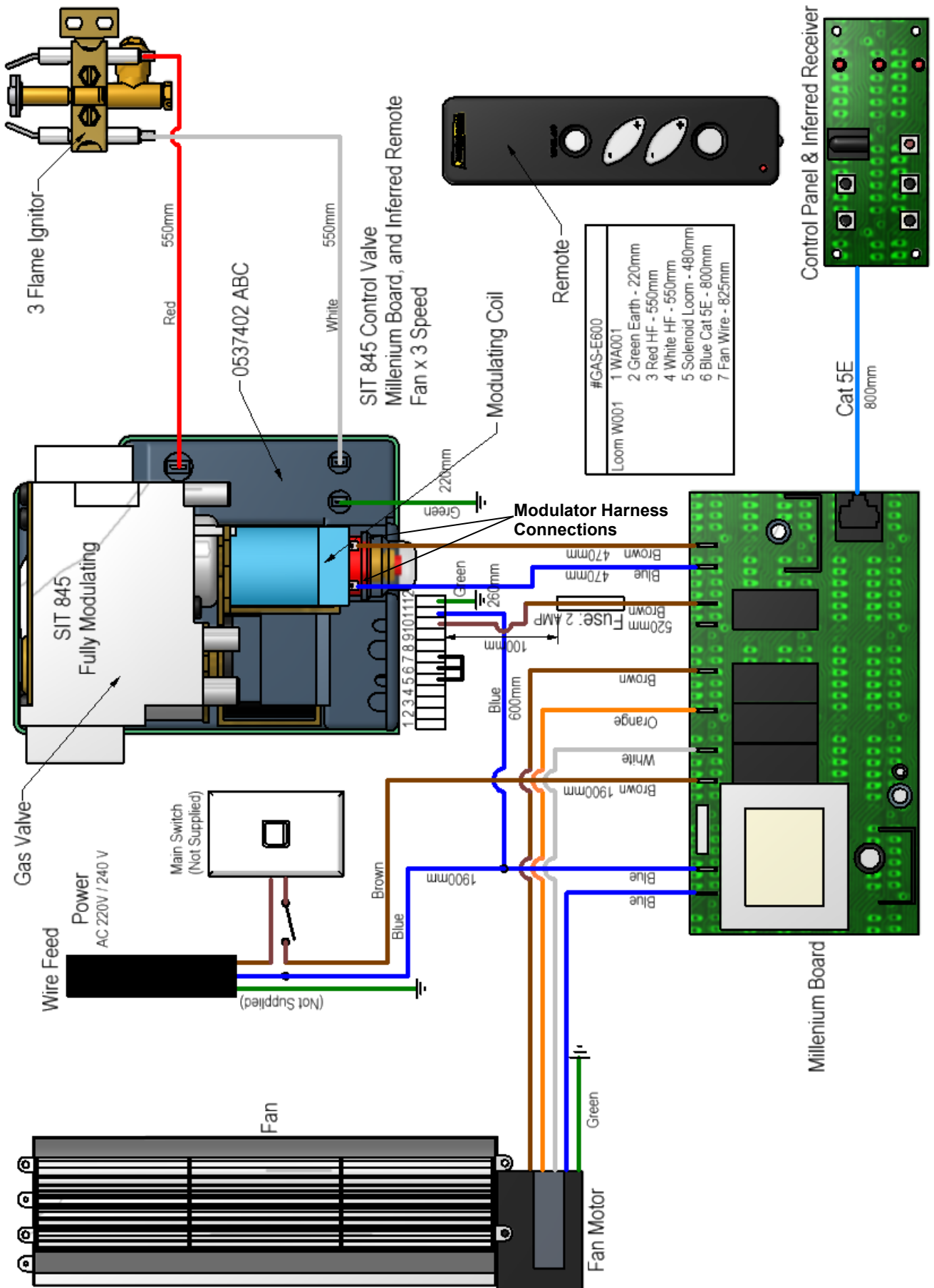

Due to continued product improvement, Warmington Ind LTD reserves the right to change product specifications without prior notification.

GENERAL NOTES

NOTES:

- These installation and operating instructions should be kept in a safe place. Should you require another copy, download from the **Warmington** website www.warmington.co.nz.
- Warranty - for full details on product warranties, contact your local Authorised Warmington Retailer.
- Correct installation, operation and maintenance must be maintained to comply with the **Warmington** Warranty.
- The appliance and flue system must be installed in accordance with relevant standards and the appropriate building codes.
- This appliance must be serviced annually and any service operation must be carried out by a qualified service person.

WARNINGS:

- **WARNING; ANY MODIFICATION OF THE APPLIANCE THAT HAS NOT BEEN APPROVED IN WRITING BY THE TESTING AUTHORITY IS CONSIDERED A BREACH OF NZ STANDARDS.**
- **WARNING; DO NOT USE OR STORE FLAMMABLE LIQUIDS OR AEROSOLS IN THE VICINITY OF THIS APPLIANCE WHILST IN OPERATION.**
- **WARNING; DO NOT PLACE FLAMMABLE MATERIALS ON OR AGAINST THIS APPLIANCE.**
- **CAUTION:** THIS APPLIANCE SHOULD BE MAINTAINED AND OPERATED AT ALL TIMES IN ACCORDANCE WITH THESE INSTRUCTIONS.
- **CAUTION:** ALL SERVICING MUST BE CARRIED OUT BY AN AUTHORISED SERVICE TECHNICIAN.
- **CAUTION:** MAKE SURE THE USE OF CORRECT FUEL TYPE WITH THIS APPLIANCE.

NOTE: Keep a copy of these instructions for operating and maintenance guidelines.



Industries 1994 LTD
PO Box 58652, Botany 2163, Auckland
www.warmington.co.nz

Due to continued product improvement, Warmington Ind LTD reserves the right to change product specifications without prior notification.