

# Warmington Gas Open Fire

## SG 1250 Single Flue Firebox

Fire, Flue System to Comply with NZS 5261 / 5262 : 2003

**Due to continued product improvement, Warmington Ind LTD reserves the right to change product specifications without prior notification.**

Read all the Instructions carefully before commencing the Installation. Failure to follow these instructions may result in a fire hazard and void the warranty

For Specification See: [www.warmington.co.nz](http://www.warmington.co.nz)

Copyright ©

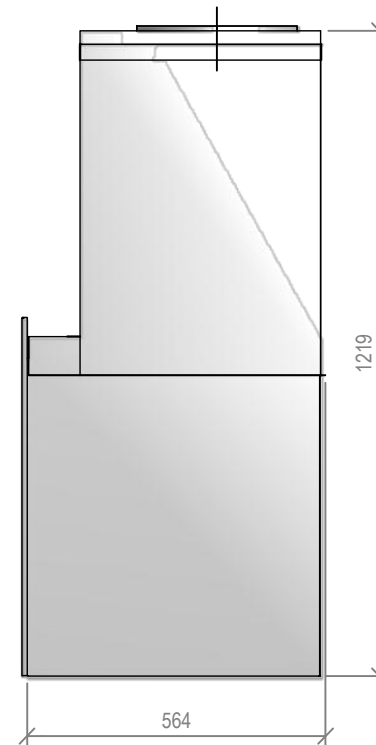
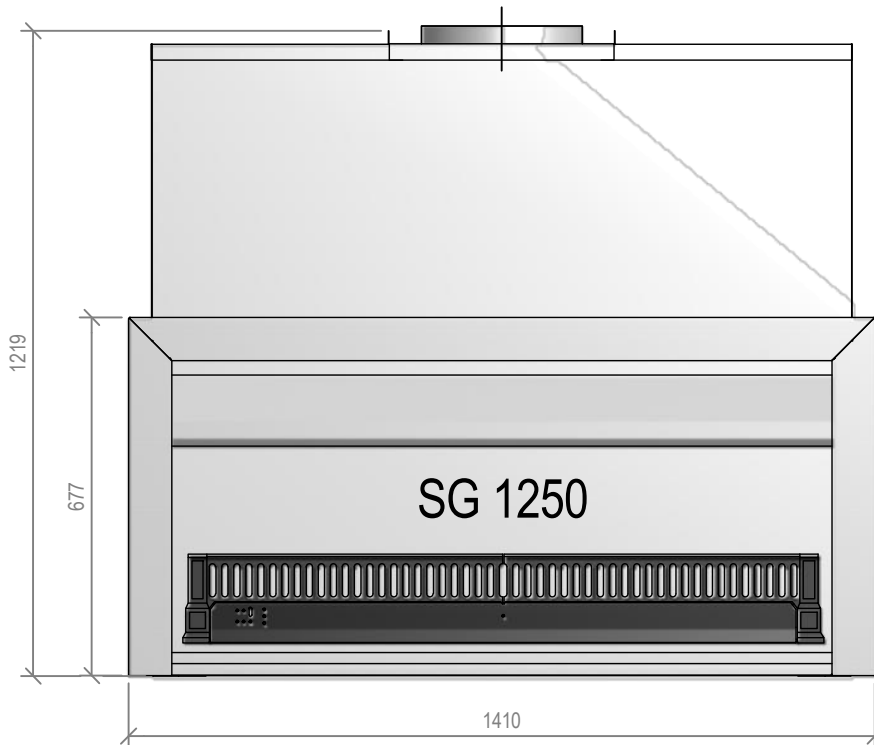

<b>Warmington Industries Ltd.</b>			
PH: 09 273 9227 FAX: 09 273 9241 WEB: <a href="http://www.warmington.co.nz">www.warmington.co.nz</a>			
TITLE	SG 1250 SINGLE FLUE FIREBOX		
DRAWN	ALAN	DATE	12/07/11
SCALE	NOT TO SCALE	REVISION	01

B-B

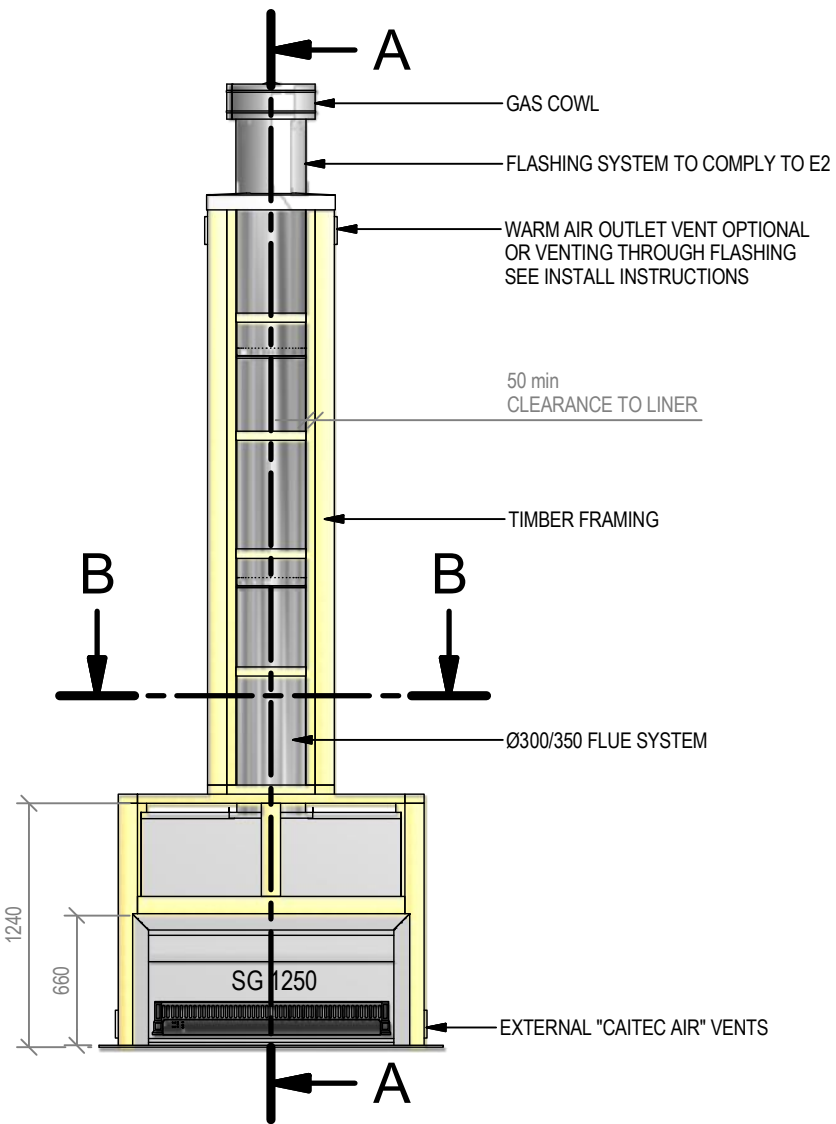
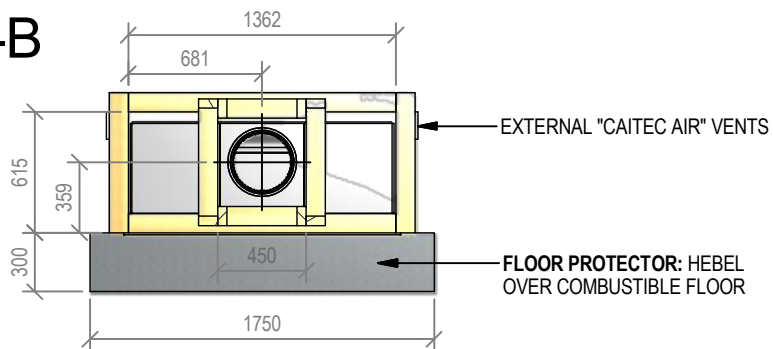

# Warmington Gas Open Fire

## SG 1250 Single Flue Timber Framing

Fire, Flue System to Comply with NZS 5261 / 5262 : 2003

**Due to continued product improvement, Warmington Ind LTD reserves the right to change product specifications without prior notification.**

Read all the Instructions carefully before commencing the Installation. Failure to follow these instructions may result in a fire hazard and void the warranty

For Specification See: [www.warmington.co.nz](http://www.warmington.co.nz)

Copyright ©

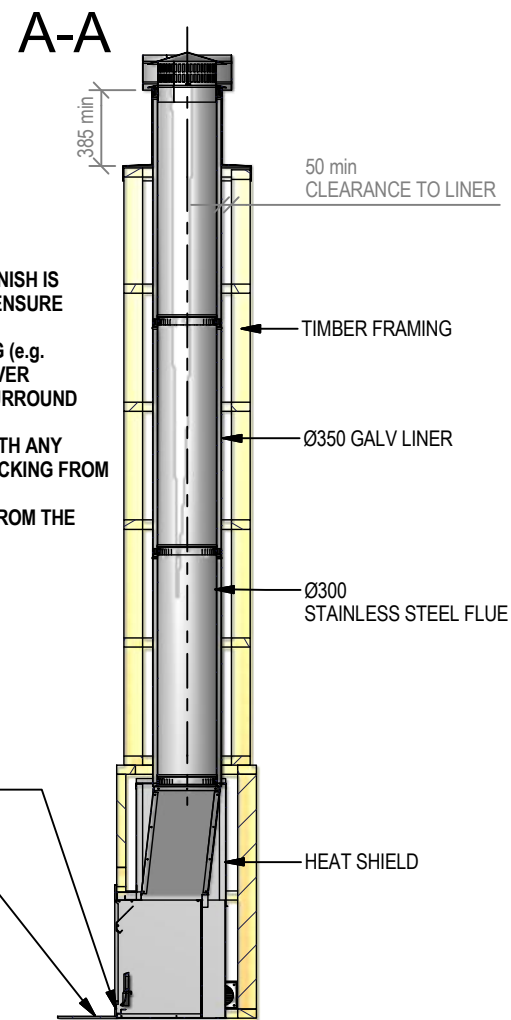

**IMPORTANT NOTE:**

WHERE AN INTERNAL WALL BOARD FINISH IS REQUIRED AROUND THE FIREPLACE, ENSURE ALLOWANCE IS MADE TO PLACE NON COMBUSTIBLE INTERNAL WALL LINING (e.g. PROMINA ETERPAN, SUPALUX) TO COVER THE EXTENT OF THE HEBEL BLOCK SURROUND

DIRECTLY TOUCHING THE FIREBOX WITH ANY BOARD OR PLASTER MAY CAUSE CRACKING FROM HEAT EXPANSION  
ALLOW 3mm MINIMUM SPACE AWAY FROM THE FIREBOX

ENSURE THE LOWER AIR INTAKE IS NOT OBSTRUCTED

ALLOW FINISHING ON FLOOR PROTECTOR

**NOTE:**

WARMINGTON CAITEC AIR IS REQUIRED  
SEE SPECIFIC INSTALL INSTRUCTION

<b>Warmington Industries Ltd.</b>		PH: 09 273 9227 FAX: 09 273 9241 WEB: <a href="http://www.warmington.co.nz">www.warmington.co.nz</a>	
TITLE	SG 1250 SINGLE FLUE TIMBER FRAMING	DATE	12/07/11
DRAWN	ALAN	REVISION	01
SCALE	NOT TO SCALE		

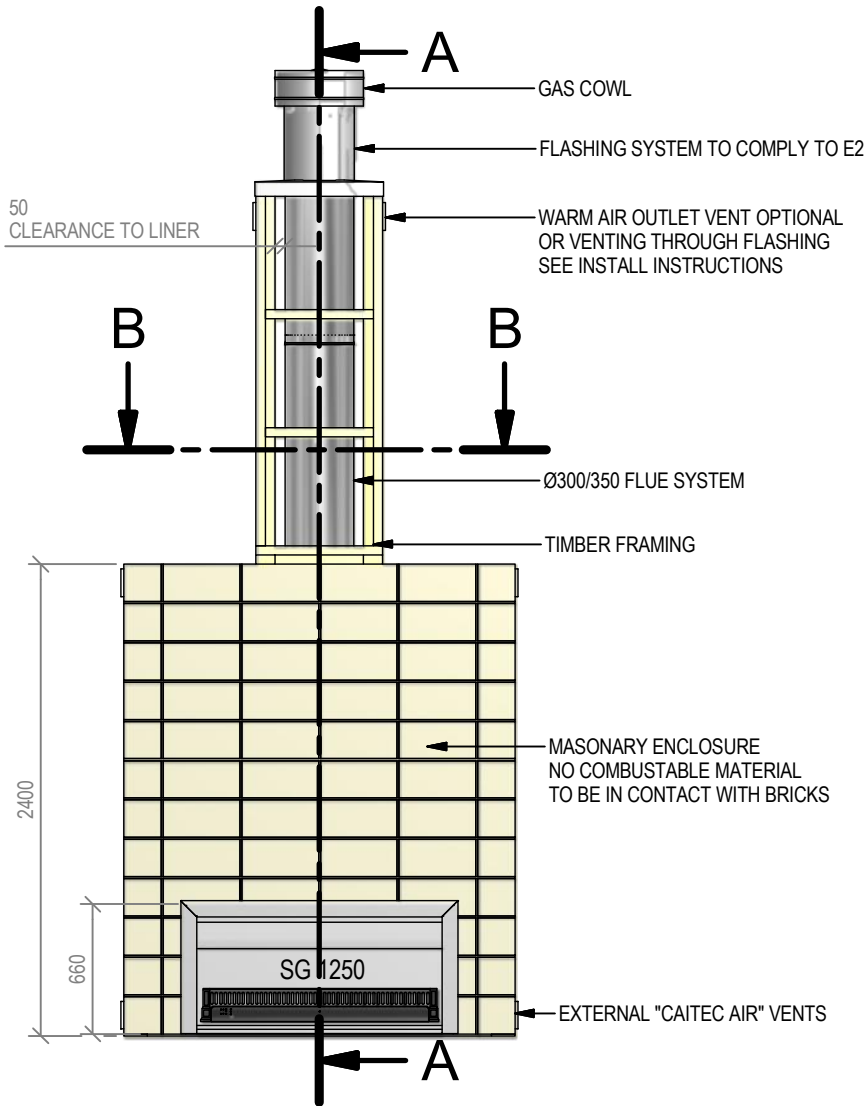
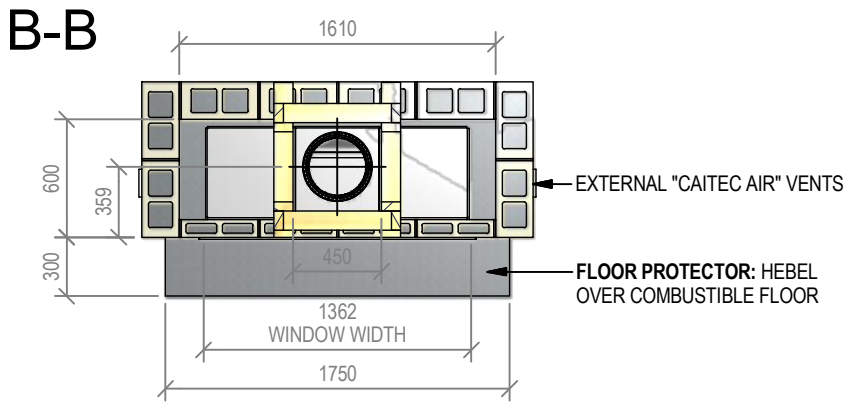

# Warmington Gas Open Fire

## SG 1250 Single Flue Block Enclosure

Fire, Flue System to Comply with NZS 5261 / 5262 : 2003

**Due to continued product improvement, Warmington Ind LTD reserves the right to change product specifications without prior notification.**

Read all the Instructions carefully before commencing the Installation. Failure to follow these instructions may result in a fire hazard and void the warranty

For Specification See: [www.warmington.co.nz](http://www.warmington.co.nz)

Copyright ©

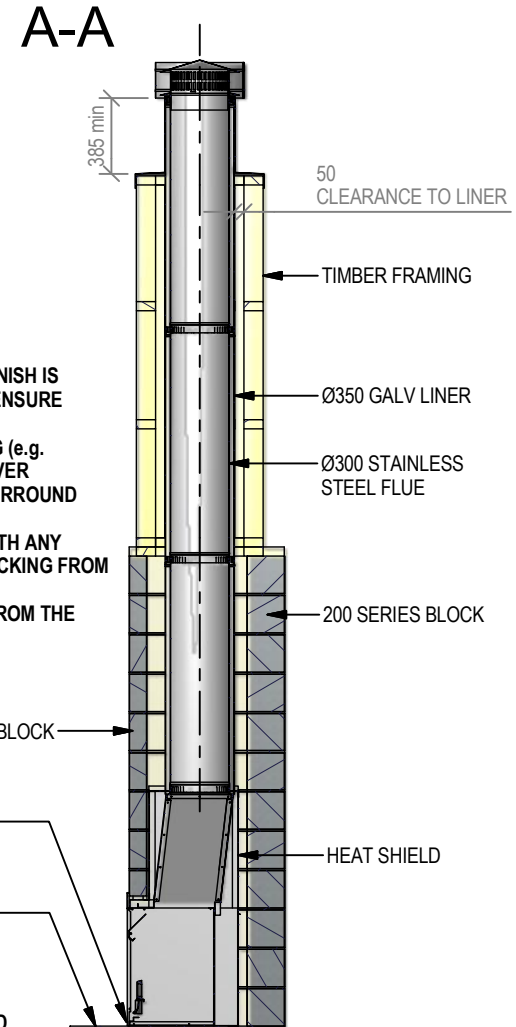

**IMPORTANT NOTE:**

WHERE AN INTERNAL WALL BOARD FINISH IS REQUIRED AROUND THE FIREPLACE, ENSURE ALLOWANCE IS MADE TO PLACE NON COMBUSTIBLE INTERNAL WALL LINING (e.g. PROMINA ETERPAN, SUPALUX) TO COVER THE EXTENT OF THE HEBEL BLOCK SURROUND

DIRECTLY TOUCHING THE FIREBOX WITH ANY BOARD OR PLASTER MAY CAUSE CRACKING FROM HEAT EXPANSION  
ALLOW 3mm MINIMUM SPACE AWAY FROM THE FIREBOX

ENSURE THE LOWER AIR INTAKE IS NOT OBSTRUCTED

ALLOW FINISHING ON FLOOR PROTECTOR

**NOTE:**

WARMINGTON CAITEC AIR IS REQUIRED  
SEE SPECIFIC INSTALL INSTRUCTION

<b>Warmington Industries Ltd.</b>			
PH: 09 273 9227 FAX: 09 273 9241 WEB: <a href="http://www.warmington.co.nz">www.warmington.co.nz</a>			
TITLE	SG 1250 SINGLE FLUE BLOCK ENCLOSURE	DATE	12/07/11
DRAWN	ALAN	REVISION	01
SCALE	NOT TO SCALE		