

Nouveau BBQ 900-1100-1250-1500 Single Flue

Outdoor BBQ Cooking Fire—Wood Burner Installation Instructions

Note: FLUE SYSTEMS Casing....

Flue system may require to be doubled lined to comply.
Ref ASNZS:2918:2001 4.3 flue pipe casing.

Important Note:

All load bearing structures are to
be Engineered to carry load.

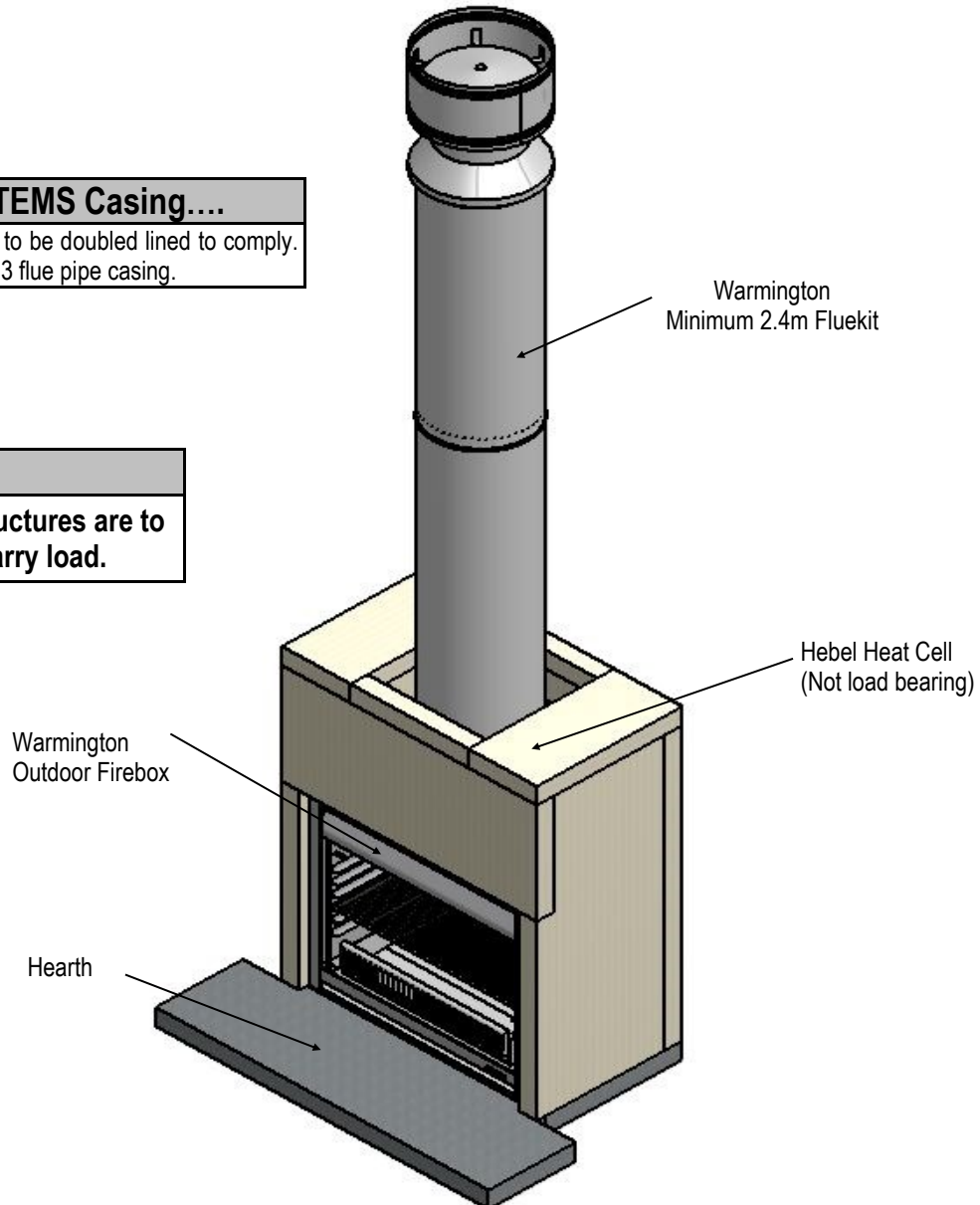

Visit www.warmington.co.nz for Spec's, DWG's and PDF uploads of Fires

Fire, Flue System and Instructions to Comply with ASNZS 2918:2001

Keep these Instructions for further reference.....Ensure that you have the correct and current Installation details for the Warmington Fire

Installation

The Warmington unit is to be Installed by a Certified Warmington Installer or an Approved NZHHA Installation Technician .
See www.homeheat.co.nz/members for a Certified NZHHA SFAIT Installer in your area .

IMPORTANT

Read all the Instructions carefully before commencing the Installation. Failure to follow these Instructions may result in a Fire Hazard and void the warranty .

POINTS TO CONSIDER PRIOR TO INSTALLATION

Location of the fire. Open fires are better located at one end of a room or area, as they project the heat away from their opening.

Venting to the cavity.

This air is to allow the cavity to vent the warm air. This warm air helps keep the fire and flue system from getting too cold. If the flue and fire get too cold the system may soot often and require cleaning. Each fire has different ways of venting the cavity.

The Topography of the land .

The slope and position of the land in relation to the home has a bearing on how the wind will interact with the fire and flue system. Care needs to be taken to ensure that the flue termination is in the correct position to maximise performance.

The prevailing wind.

Care needs to be taken to ensure that the flue termination is in the correct position as wind and gusts that hit the flue and cowl system may overcome the cowl and draft back down the flue into the home. This can be a combination of down draft and high pressure.

Hearth and plinth:

The height of the hearth off the floor. The finishing that is to be used on the hearth is to be allowed for at the design stage.

Positioning of the Flue system:

There is a maximum distance that an offset flue can be installed. Reference to AS/NZS : 2918

Flue And Fire Clearance:

To be maintained to the manufacturer's Instructions.

Installation Notes:

A rebate of 40mm is recommended from the front face of the surround to the front of the fire to reduce the ingress of water into the fire.

Due to the expansion and contraction of metal fireplaces a 3mm gap between the flange and the finished surround should be maintained.

INSTALLATION ORDER OF OPERATIONS

Prior to Construction and Installation Important Notes:

Install to AS/NZS 2918:2001.

Install to manufacturer's specifications.

All new installations require a permit.

For special requirements concerning materials (timber mantle and surrounds) within close proximity of Warmington products, please contact your local Warmington Technical Consultant.

Stage 1: Frame Construction Procedure by Builder.

Mark out flue centre.

Mark out heat cell clearance requirements.

Construct Plinth only, to required height. *

Stage 2: Install Procedure by Certified "Warmington Installer" only.

Fit Fire to Plinth.

Fit Adaptor to Firebox.

Construct Hebel Enclosure around Nouveau Firebox. (Ensure a 40mm rebate to form a Drip Edge).

Fit Flue System.

Fit Cowl and Flashing System .

Stage 3: Finishing Procedure by Builder.

Construct Hearth to required Thickness. *

Finish Hebel Enclosure and Hearth to Customer requirements (e.g. paint / tiles).

Close in Hebel Enclosure and Chimney Chase. (If in timber alcove).

* Note: Certified NZHHA SFAIT Installer can also Install Hearth and Plinth.

Ensure that the Warmington and flue system is swept annually or more frequently if required.

To Sweep Flue and Firebox:

Cover Front of Fire with sheets.

Remove Cowl from top of chimney.

Sweep from the top, down the flue.

Remove all soot and ash.

Ensure Cowl and Bird Protection is clean and replaced.

Visually Inspect Fireplace and Flue System.

WARMINGTON NOVEAU FIREBOX DIMENSIONS

Description		SN 900	SN 1100	SN 1250	SN 1500
Firebox Width	A	900	1100	1250	1500
Firebox Height	B	760	760	910	910
Firebox Depth	C	450	450	600	600
Flange Width	D	950	1150	1300	1550
Flange Height	E	785	785	935	935
Adaptor Height	F	425	425	480	480

Minimum Flue Height	
Flue Height	2400
Measured From Top of Adaptor	B + F + 2400

HEBEL SURROUND DETAILS DIMENSIONS

Description		SN 900	SN 1100	SN 1250	SN 1500
Surround Width	G	1110	1310	1460	1710
Surround Height	H	1325	1325	1640	1640
Surround Depth	I	635	660	770	770
Window Width	J	960	1160	1310	1560
Window Height	K	790	790	940	940
To Centre of Flue	N	312	312	448	387
Flue Diameter	O	300	350	350	450
Liner Diameter	P	400	450	450	550
Flue Centre	Z	272	272	408	347

(From front face of Firebox Flange)

Note:

- 'Z' dimension is from Flue Centre to Firebox Front Flange Not including 40mm rebate from Hebel enclosure.
- 'N' dimension is from Flue Centre to the Hebel enclosure front.

HEBEL HEARTH DIMENSIONS

Description		SN 900	SN 1100	SN 1250	SN 1500
Hearth Width	L	1450	1650	1650	1900
Hearth Projection	M	380	380	850	850

Check List	
Firebox	
Ash Pan	
Rack/Hotplate & Grill	
Weather Shield	
Badge	
Adaptor & Bolts	
Packed by	

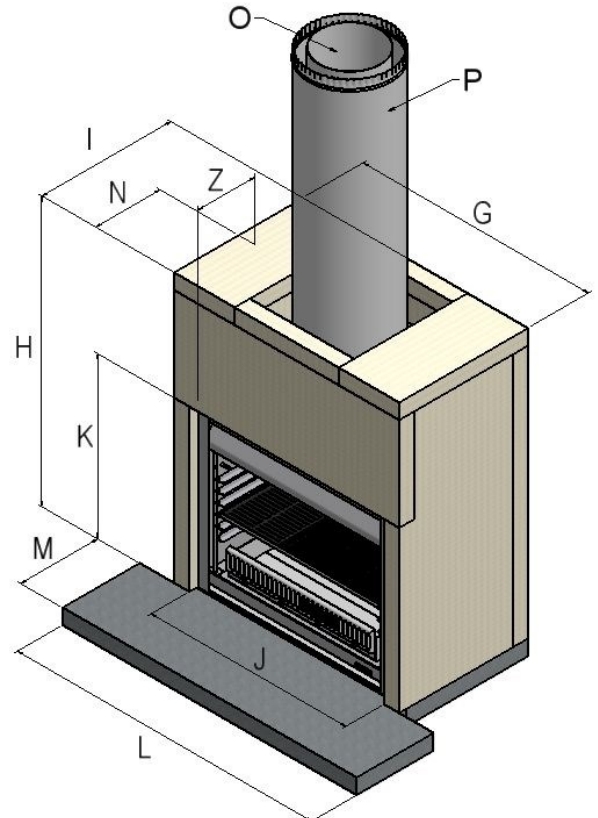
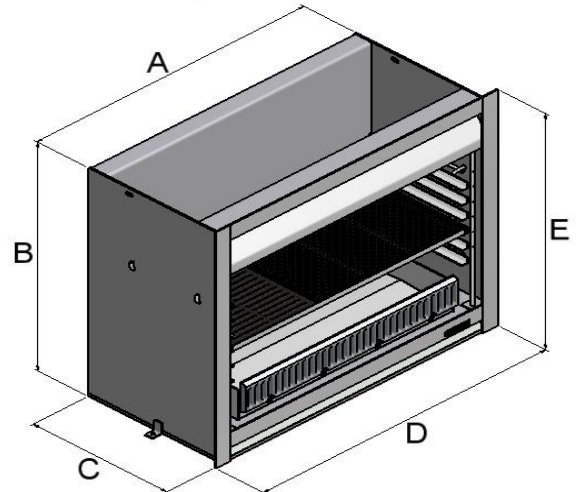
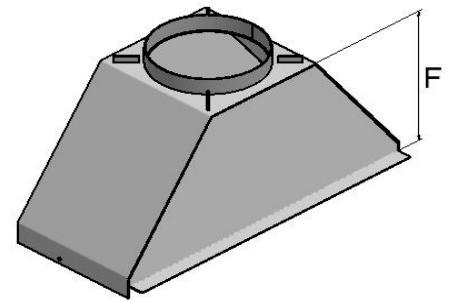

Note:
Firebox is recessed 40mm into Hebel surround.

FIREBOX INSTALLATION

This is a general installation guide only – Contact a “NZHHA Installer” for Installation Advice.

See : www.homeheat.co.nz , choose “members” & pick your Area & Fire type (wood / Gas etc) this will provide you with a NZHHA Certified Installer (use the SFAIT Installers Only .)

1. All the dimensions are minimums.
2. Fit the plinth into position in the cavity. If installing onto a wooden floor, ensure that an insulating plinth is fitted as per the specifications. **Ensure that the plinth is elevated to allow for finishing on the hearth - (see Hearth and plinth details)**
3. Fit the firebox into the cavity. Bolt the fire box to the plinth or through to the floor with the bolting point provided on the Left and Right hand sides of the fire box (seismic restraints).
4. Fit the adaptor to the fire box. Ensure that exhaust sealant is used between the fire and adaptor. Bolt into position with the bolt in the Left and right hand sides of the fire box.
5. Install the flue system.
6. Fit the Hebel Heat cell around the fire. A general minimum lay out is shown in this Specification.

HEARTH & PLINTH CONSTRUCTION DETAILS

IMPORTANT NOTE:

Note: Hearth and Plinth Construction.

For Combustible Flooring an Insulating Hearth and Plinth of 75mm Hebel is required.

Plinth to be Offset above Hearth by the Hearth Finishing's (e.g. Tiles / Granite / Solid Plaster / etc)

All Load Bearing cantilevered Hearths must be Engineered to carry loads.

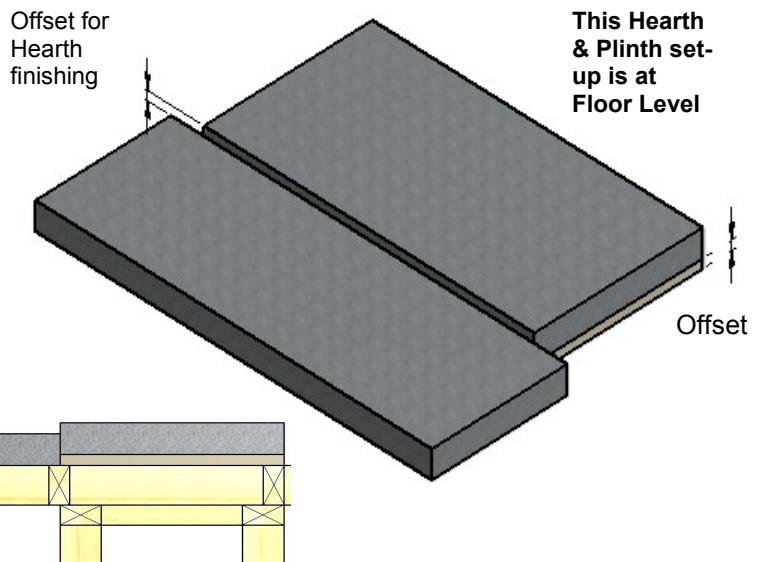

This is an example of a Raised & cantilevered Hearth. See page 15 for further Raised Hearth Details.

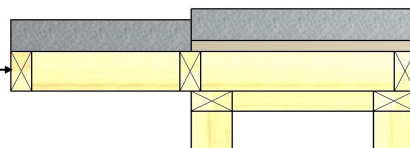

***Note: If Solid Plastering the structure , it is recommended to use a Fibreglass Mesh with a Latex Based Solid Plaster to minimise the chance of the Solid Plaster cracking. (See your Solid Plasterer for correct materials and applications) .**

PLAN, FRONT ELEVATION & CROSS SECTION

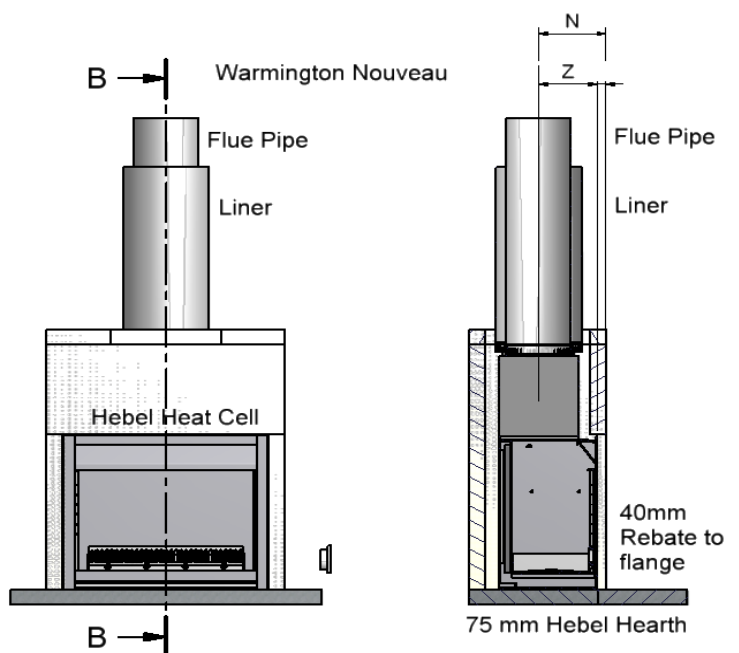
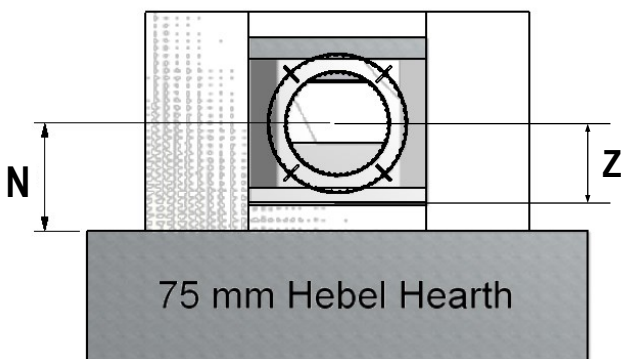

Visit the Warmington Website for Hebel instruction (PDF download) www.warmington.co.nz

TIMBER FRAMING & TRIM OUT DETAILS

Firebox		SN 900	SN 1100	SN 1250	SN 1500
Frameout Clearance Width	O	1170	1370	1490	1770
Frameout Clearance Depth	P	665	690	800	800
Frameout Clearance Height	Q	2230	2230	2230	2230
Hearth Width	R	1450	1650	1650	1900
Hearth Projection	S	380	380	850	850
Window Height	V	1355	1430	1745	1745
Window Width	W	1170	1370	1490	1770
Chimney Chase Clearance	X	500	550	550	650

MINIMUM HEAT CELL ALCOVE CLEARANCES & FRAME OUT

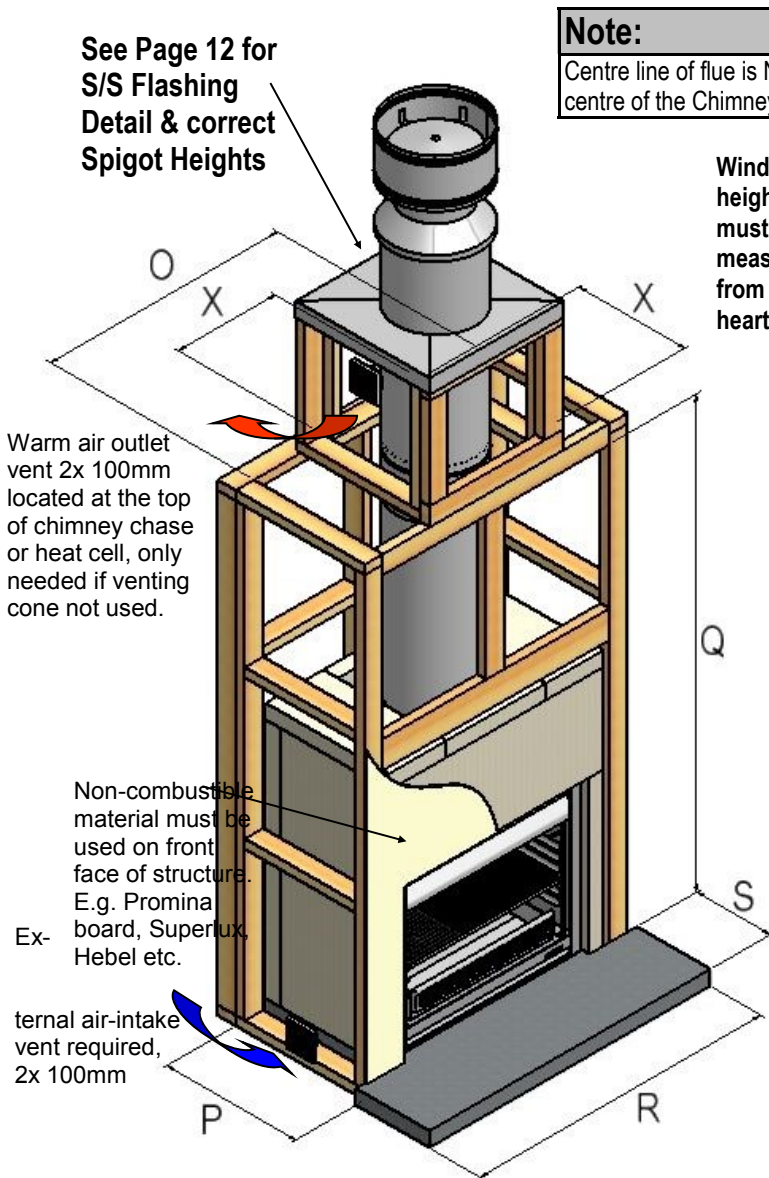

Note:
Centre line of flue is NOT in centre of the Chimney chase

Window height 'V' must be measured from top of hearth.

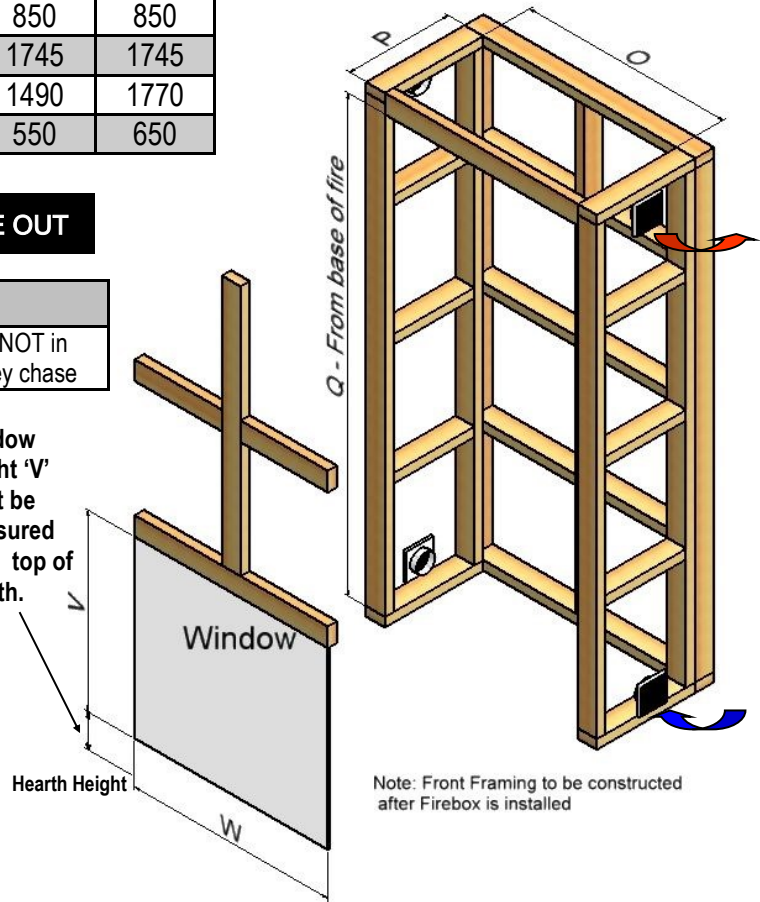

Important Notes:

All framing dimensions are internal only.

All timber framing & cladding must be constructed to suit an outdoor environment as per NZ building code.

Firebox is recessed 40mm into Hebel Surround.

*Note: If Solid Plastering the structure, it is recommended to use a Fibreglass Mesh with a Latex Based Solid Plaster to minimise the chance of the Solid Plaster cracking. (See your Solid Plasterer for correct materials and applications)

TIMBER: PLAN, FRONT ELEVATION & CROSS SECTION

Firebox		SN 900	SN 1100	SN 1250	SN 1500
Hearth Width	R	1450	1650	1650	1900
Hearth Projection	S	380	380	850	850
Plinth Width	T	1170	1370	1490	1770
Plinth Depth	U	665	690	800	800
Centre of Flue	J	312	312	448	387

Important Note:
All load bearing Structures are to be Engineered to carry load.

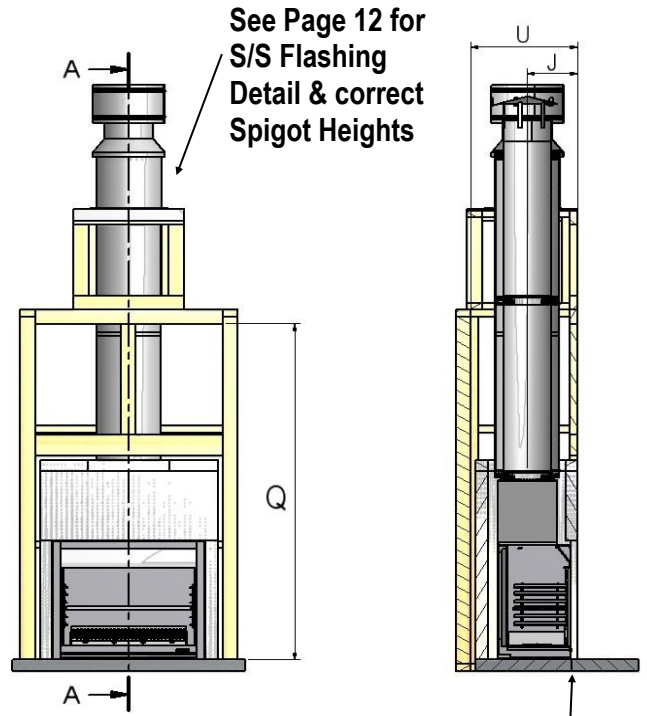
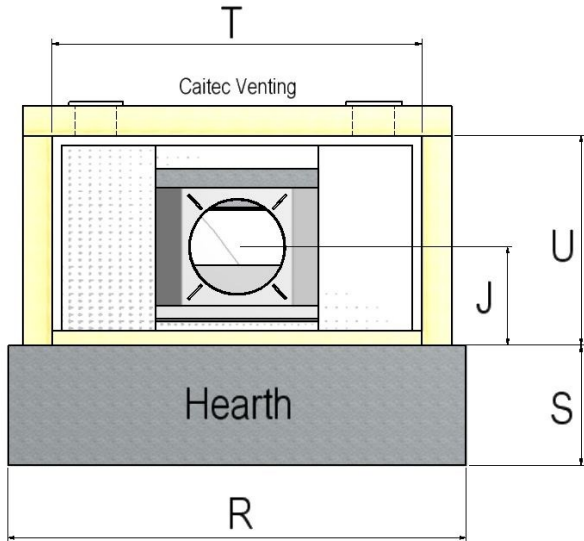

BLOCK: PLAN, FRONT ELEVATION & CROSS SECTION

Firebox		SN 900	SN 1100	SN 1250	SN 1500
Hearth Width	RR	1590	1650	1650	1900
Hearth Projection	SS	380	380	850	850
Plinth Width	TT	1210	1210	1610	1610
Plinth Depth	UU	600	600	700	700
Centre of Flue	JJ	312	312	448	387

Note:
Centre Line of Flue is 'NOT' in centre of Alcove

Firebox to be rebated min 40mm

*The SN 1100 must have a 50mm offset adaptor using these installation details.

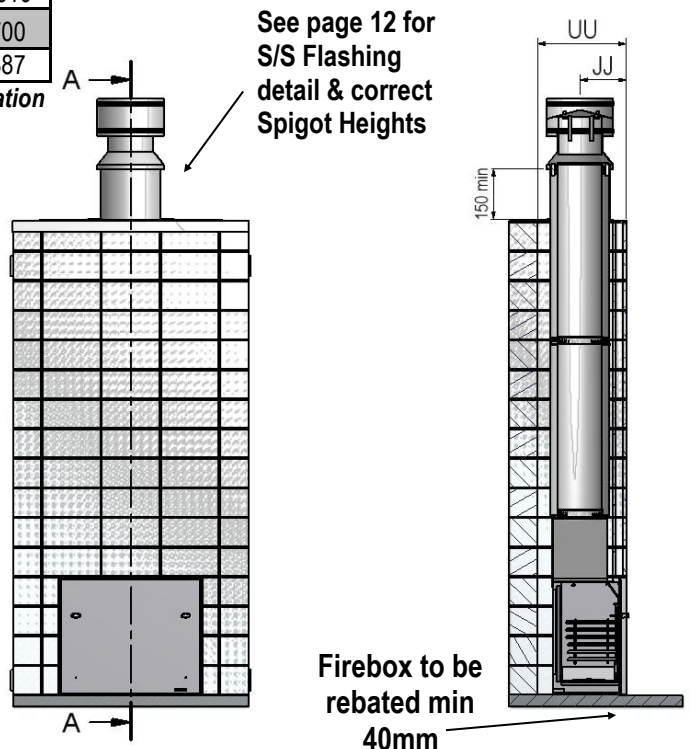
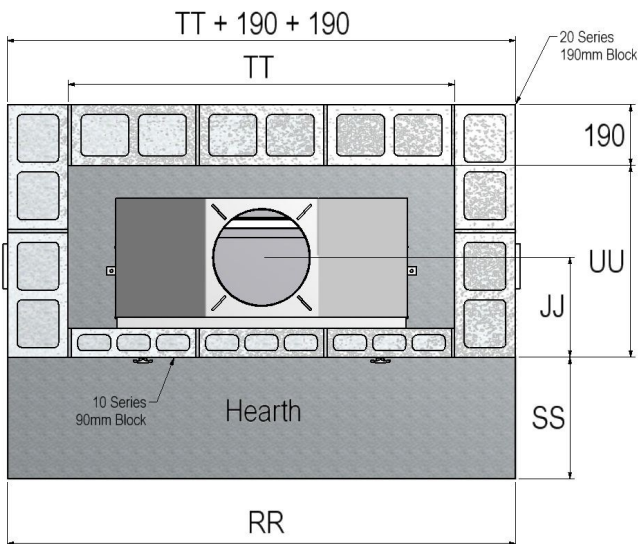

BLOCK ALCOVE & TRIM OUT DETAILS

Firebox		SN 900	SN 1100*	SN 1250	SN 1500
Plinth Width	TT	1210	1210	1610	1610
Plinth Depth	UU	600	600	700	700
Hearth Width	RR	1590	1650	1650	1900
Hearth Projection	SS	380	380	850	850
Window Height	VV	790	790	940	940
Window Width	WW	960	1160	1310	1560

See Page 12 for S/S Flashing Detail & correct Spigot Heights

Note:
Centre Line of Flue is 'NOT' in centre of Alcove

*The SN 1100 must have a 50mm offset adaptor using these installation details.

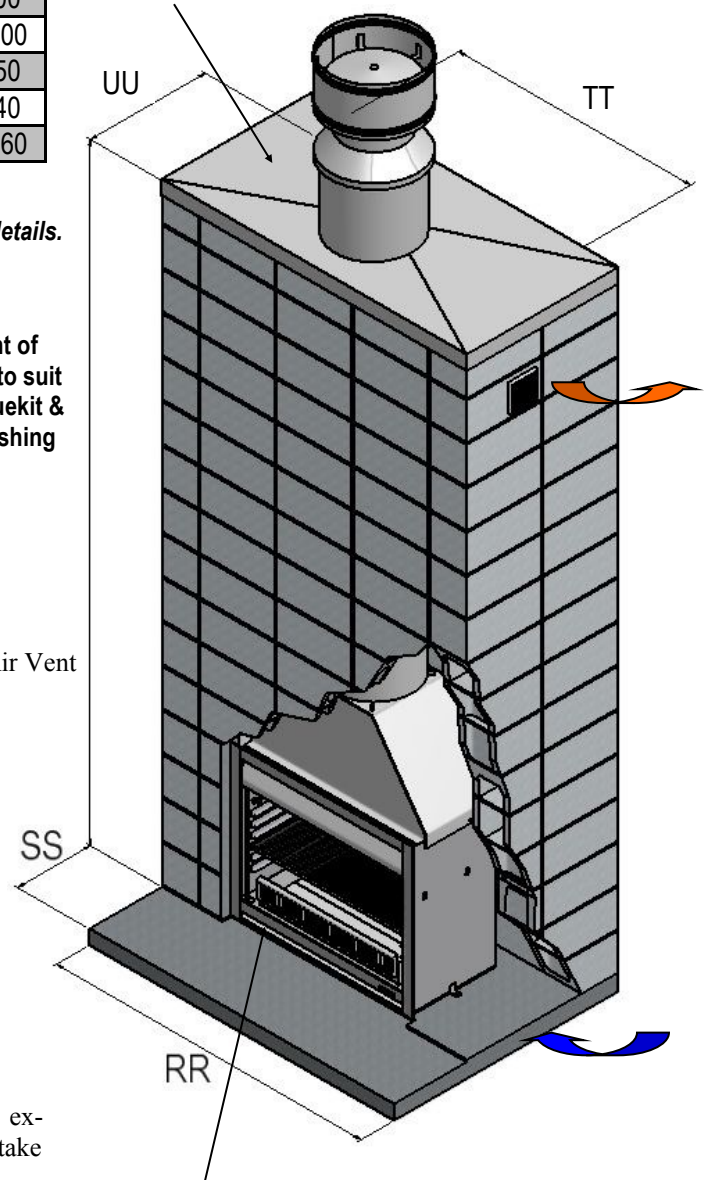
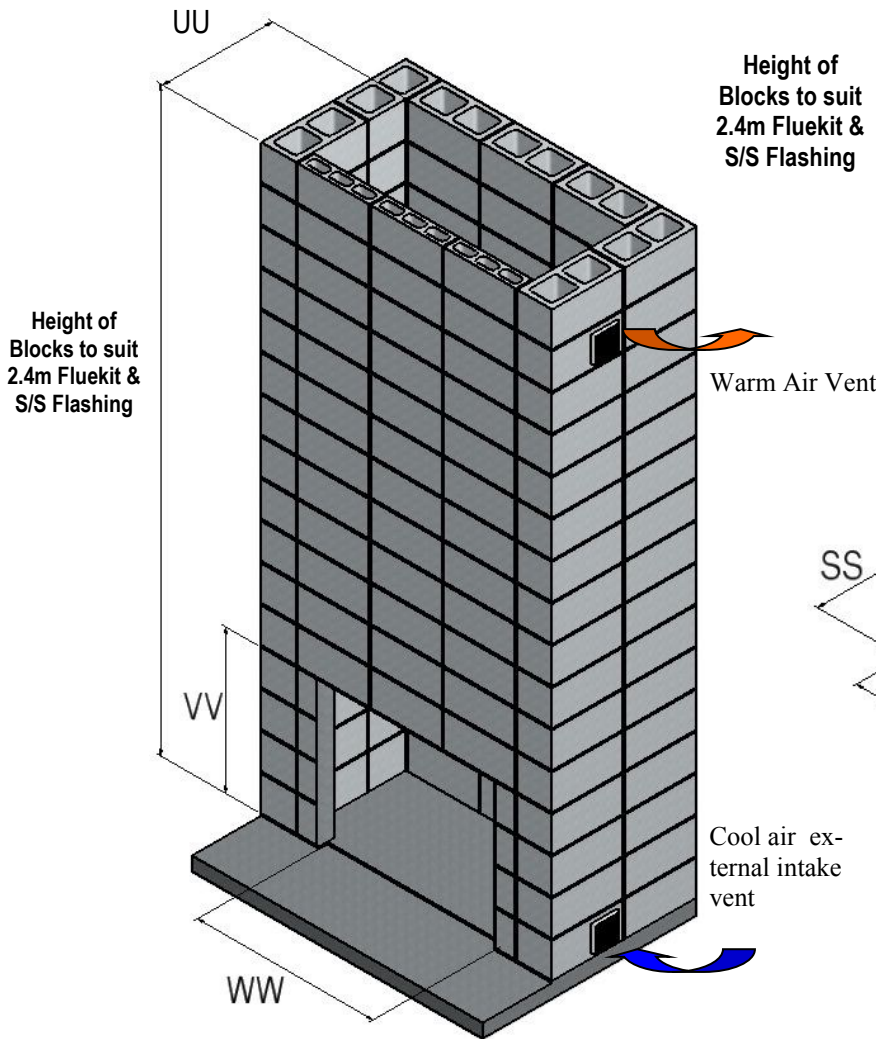

MINIMUM HEAT CELL BLOCK ALCOVE CLEARANCES

Note:
Ensure that the Fire and Flue System is installed before the alcove access is blocked off. Block modules may vary to the drawing see Blocklayer for further details.
All load bearing structures are to be Engineered to carry load.

HEBEL HEAT CELL & CUT SIZES FROM PANELS for SN900

The Hebel Heat cell is constructed around the firebox, using 75mm Hebel (see attached minimum spec below).

(2400x600x75) Power Panels are required for basic heat cell construction as shown in detail "Firebox with Hebel Surround".

*Note: If plastering the Heat Cell structure, it is recommended to use a fibreglass mesh with a latex plaster to minimise the chance of the plaster cracking. (See your plasterer for correct materials and applications).

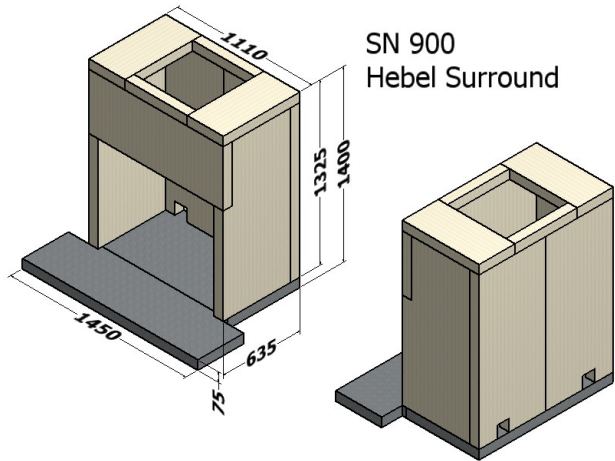

Note: HEBEL KITSET ASSEMBLY details

When purchasing the 'Hebel Heat Cell Kit' the assembly guide will be included in the kit.

These Hebel Kits are NOT designed to be load bearing.

HEBEL HEAT CELL & CUT SIZES FROM PANELS for SN1100

The Hebel Heat cell is constructed around the firebox, using 75mm Hebel (see attached minimum spec below).

(2400x600x75) Power Panels are required for basic heat cell construction as shown in detail "Firebox with Hebel Surround".

*Note: If plastering the Heat Cell structure, it is recommended to use a fibreglass mesh with a latex plaster to minimise the chance of the plaster cracking. (See your plasterer for correct materials and applications).

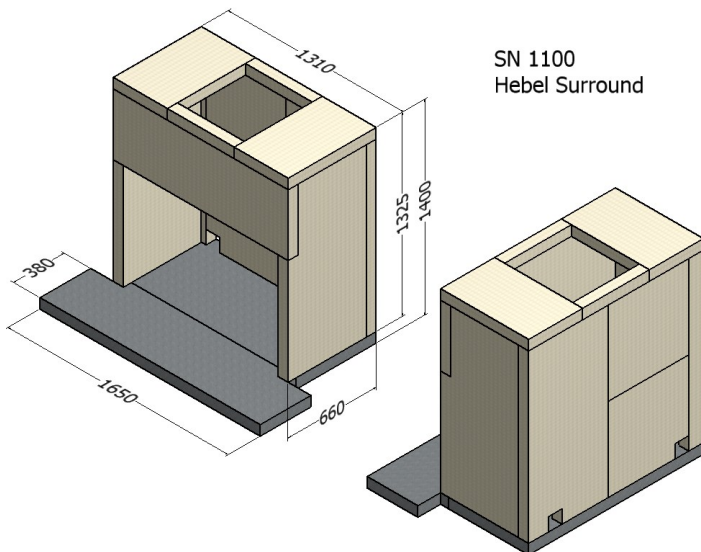

Note: HEBEL KITSET ASSEMBLY details

When purchasing the 'Hebel Heat Cell Kit' the assembly guide will be included in the kit.

These Hebel Kits are NOT designed to be load bearing.

*Note: If Solid Plastering the structure , it is recommended to use a Fibreglass Mesh with a Latex Based Solid Plaster to minimise the chance of the Solid Plaster cracking. (See your Solid Plasterer for correct materials and applications).

HEBEL HEAT CELL & CUT SIZES FROM PANELS for SN1250

The Hebel Heat cell is constructed around the firebox, using 75mm Hebel (see attached minimum spec below).

(2400x600x75) Power Panels are required for basic heat cell construction as shown in detail “Firebox with Hebel Surround”.

*Note: If plastering the Heat Cell structure, it is recommended to use a fibreglass mesh with a latex plaster to minimise the chance of the plaster cracking. (See your plasterer for correct materials and applications).

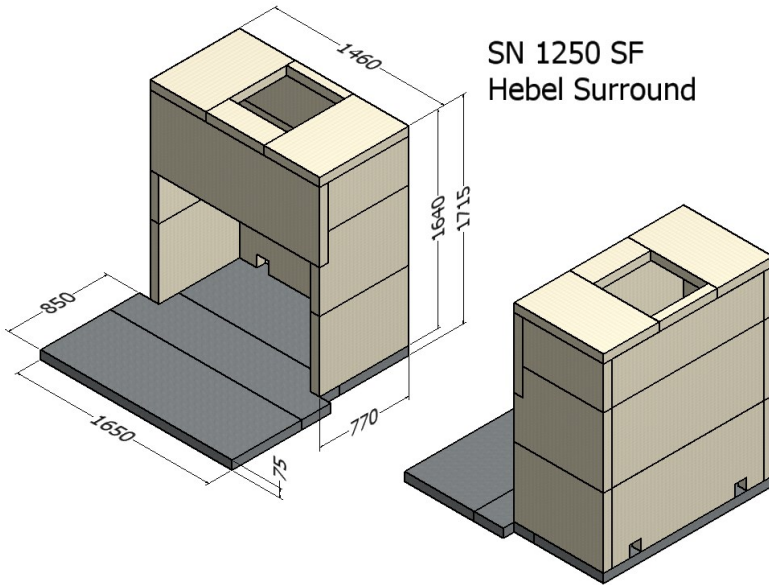

SN 1250 SF
Hebel Surround

Note: HEBEL KITSET ASSEMBLY details

When purchasing the ‘Hebel Heat Cell Kit’ the assembly guide will be included in the kit.

These Hebel Kits are NOT designed to be load bearing.

HEBEL HEAT CELL & CUT SIZES FROM PANELS for SN1500

The Hebel Heat cell is constructed around the firebox, using 75mm Hebel (see attached minimum spec below).

(2400x600x75) Power Panels are required for basic heat cell construction as shown in detail “Firebox with Hebel Surround”.

*Note: If plastering the Heat Cell structure, it is recommended to use a fibreglass mesh with a latex plaster to minimise the chance of the plaster cracking. (See your plasterer for correct materials and applications).

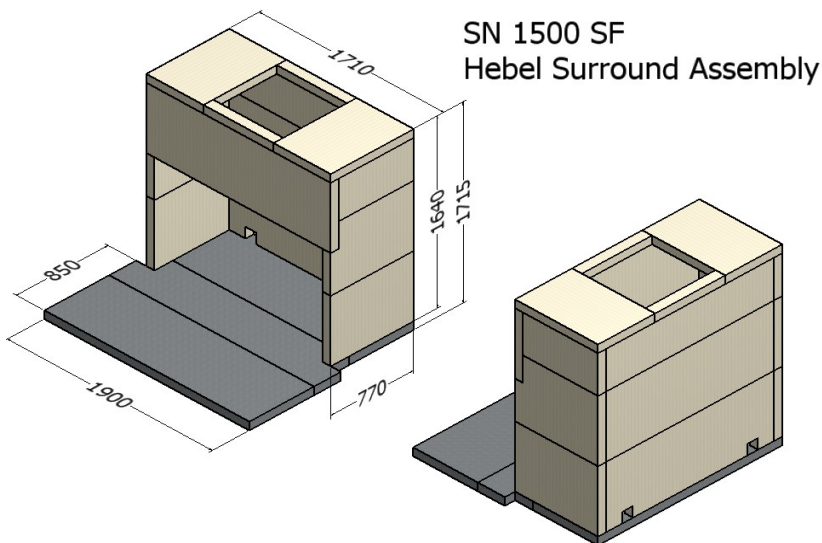

SN 1500 SF
Hebel Surround Assembly

Note: HEBEL KITSET ASSEMBLY details

When purchasing the ‘Hebel Heat Cell Kit’ the assembly guide will be included in the kit.

These Hebel Kits are NOT designed to be load bearing.

*Note: If Solid Plastering the structure , it is recommended to use a Fibreglass Mesh with a Latex Based Solid Plaster to minimise the chance of the Solid Plaster cracking. (See your Solid Plasterer for correct materials and applications) .

FLUE DETAILS DIMENSIONS

Note: FLUE SYSTEMS casing
 Flue system may require to be Doubled lined to comply.
 Ref ASNZS:2918:2001 4.3 Flue pipe casing

Minimum Flue Height	
Flue Height	2400
Measured From Top of Adaptor	B + F + 2400

Flue details	No:	SN 900	SN 1100	SN 1250	SN 1500
Cowl	1	300	350	350	450
Cone	1	300	350	350	450
Top Spider	1	300	350	350	450
Flue Diameter	2	300	350	350	450
Liner Diameter	2	400	450	450	550
Spacer	2	300/400	350/450	350/450	450/550

NOTE: Ensure that a Standard Tested Warmington Flue system is used on the Warmington fires.

FLUE SYSTEM INSTALLATION GUIDE

This is a general installation guide only – Contact a “NZHHA Installer” for Installation Advice.
 See: www.homeheat.co.nz, choose “members” & find your Area & Fire type (wood/gas etc). This will provide you with a NZHHA Certified Installer (use the SFAIT Installers only).

1. Install the first length of Flue Pipe with the crimped end down inside the adaptor collar, ensure that the Flue Pipe is tight into the collar . Rivet the Flue in 3 places around the Adaptor collar. Place a spacer around the Flue Pipe approximately 150mm above the adaptor collar. Secure in position by tightening the screw and nut.
2. Install the second length of Flue Pipe with the crimped end down into the first length and secure by Riveting in at least 3 places around the Flue Pipe joint .
3. Install the First section of Flue Pipe Liner with the crimped end up, over the flue pipe and over the spacer that is fixed to the Flue Pipe. This spacer will keep the Liner concentric around the Flue Pipe.
4. Position Flue Spacers near the Flue Pipe joint for every length of “Flue pipe” and “Liner” . Repeat the Steps from 1 – 4 to the Installed required Height of the Flue System. The Flue System is to comply with ASNZS 2918:2001 4.9.1

- The ‘flue pipe’ shall extend no less than the minimum flue height specified.
- The ‘minimum’ height of the flue system within 3m from the highest point of the roof, shall be 600mm above that point.
- The ‘minimum’ height of the flue system further than 3m from the highestpoint of the roof shall be 1000mm above the roof penetration.
- No part of any building lies in or above a circular area described by a horizontal radius of 3m about the flue system exit.

1. **NOTE:** The last length of Flue Pipe needs to extend past the Liner so that when the “Top Spider” and the “Flashing Cone” are fitted, that the Top of the “Flashing Cone” and the “Flue Pipe” are **flush**, or that the “Flue Pipe” is **5mm lower** than the “Flashing cone”.
2. Fit the “Top Spider” into position, ensure that the legs of the Spider are fitted inside the Liner and that the spider is positioned hard down onto the Liner and Tighten with the Screw and Nut.
3. Place the “Flashing Cone” over the “Flue Pipe” and press hard down onto the “Top Spider”. (Note that the “Flue Pipe” and the “Flashing Cone” are either Flush or the “Flue Pipe” is 5mm Lower than the “Flashing Cone”.) Ensure that the “Flashing Cone” is clear for the venting from the “Liner” and the “Flue Pipe”.
4. Fit the “Cowl” over the Top & Inside of the Flue Pipe . The “Cowl” , “Flashing Cone”, and the “Flue pipe” can be secured to each other with the use of a Stainless Steel Self Tapping Screw. This will secure the “Cowl System” in high wind areas.
5. Flue Systems may require Bird Protection due to the Installation and locations, discuss this with your Installer for the best advice as this may not be supplied .
6. If the Flue System is Installed into a “Chimney Chase”, allow for Air Venting as close to the top of the Chase as possible , or allow Venting through the “Chimney Chase Flashing”. A “Venting Flashing Cone” and a 25mm gap around the Liner with a “Venting Flashing Cone-Spider” can be used. Ref to Page 11-12 in this Specification .

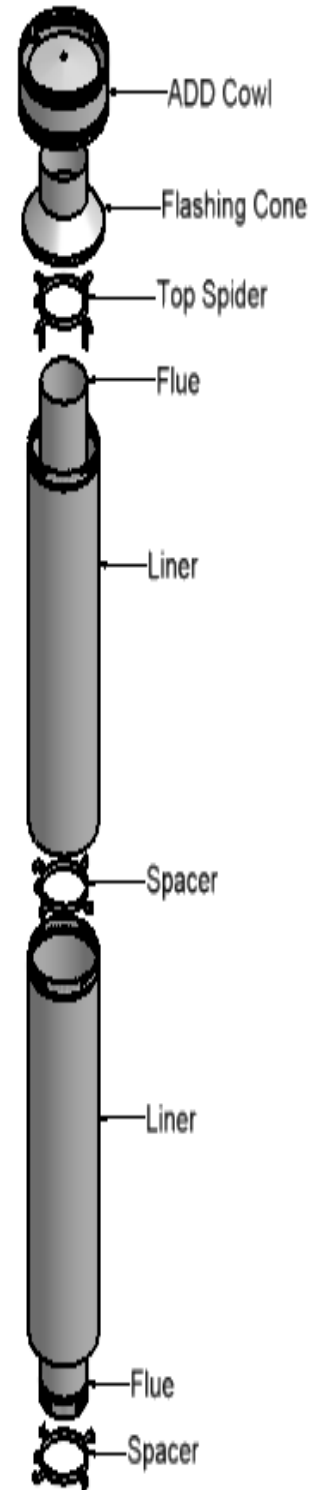

FLUE PENETRATION Vented through Alcove (Single lined Flue System)

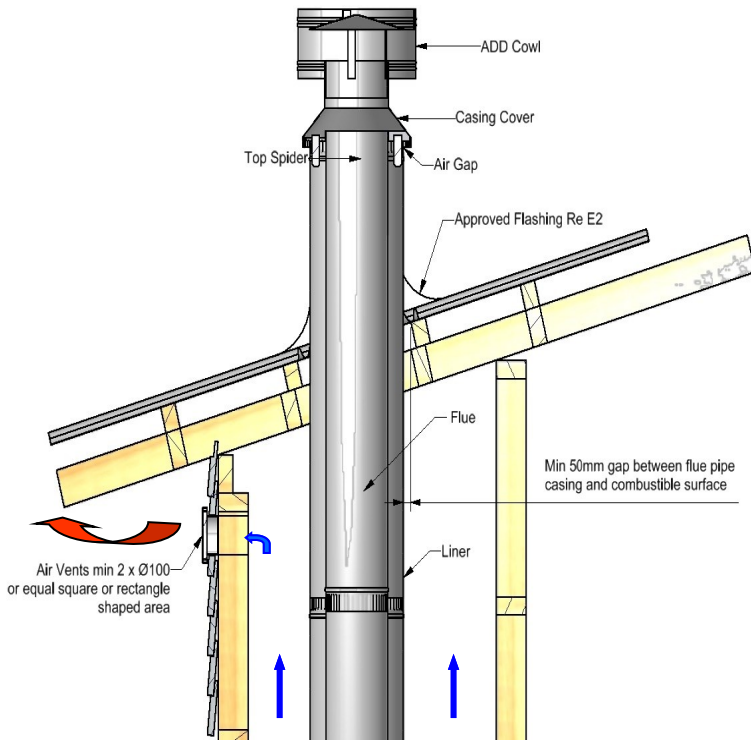

FLUE PENETRATION Vented through Alcove (Double lined Flue System)

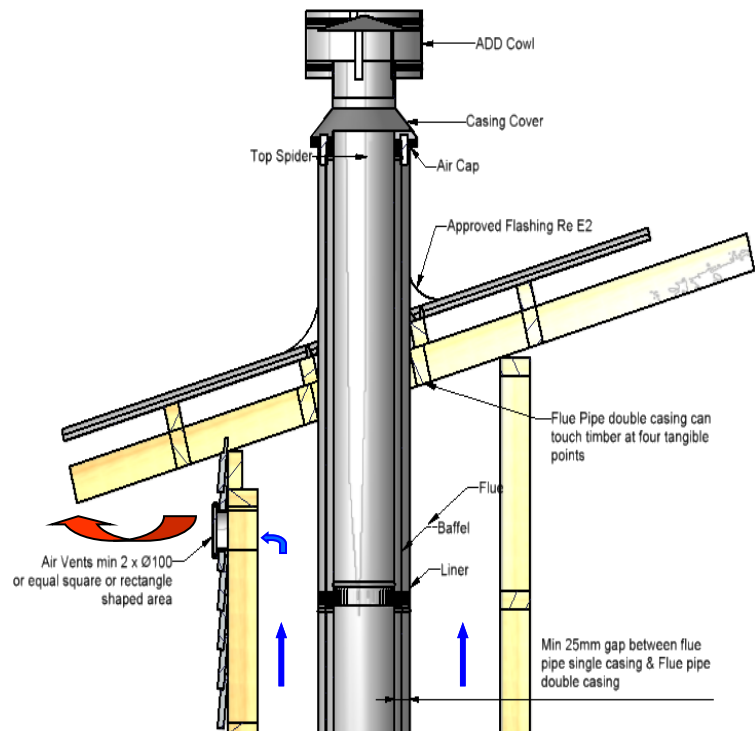

FLUE PENETRATION Vented through Top Flashing

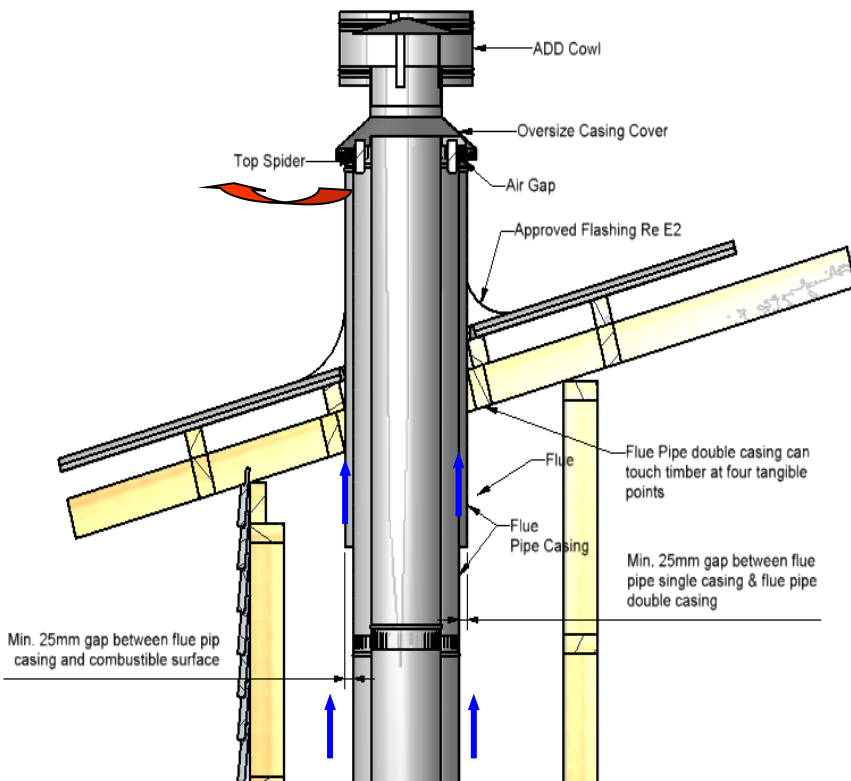

Note: FLUE SYSTEMS casing..

Flue system may require to be Doubled lined to comply. Ref AS/NZS:2918:2001 4.3 Flue pipe casing

Note :

External Requirements Refer to AS/NZS2918:2001 4.9.1

Install Flue system to AS/NZS2918:2001

When using a rubber or Bitumen flashing (Butynol, Decitite) an Additional Flue pipe Baffle is required.

All external air vents & ceiling penetrations must be bird proofed with permanently fixed screens.

All flashing to comply with E2.

All external air vents and ceiling penetrations are to be Vermin and Rodent proof.

Test Report Number	Date of Report
04/1039	20 th July 2004
04/1040	20 th July 2004
04/1041	20 th July 2004

CHIMNEY CHASE FLASHING DETAILS

Note: FLUE SYSTEMS casing..
 Flue System may require to be Doubled Lined to Comply.
 Ref ASNZS:2918:2001 4.3 Flue Pipe Casing

Note:
 Flashing Spigot Height is determined by the
 Insulation that is fitted under the Flashing.
 See Details at bottom of page.

General Chimney Chase Flashing Lay Out

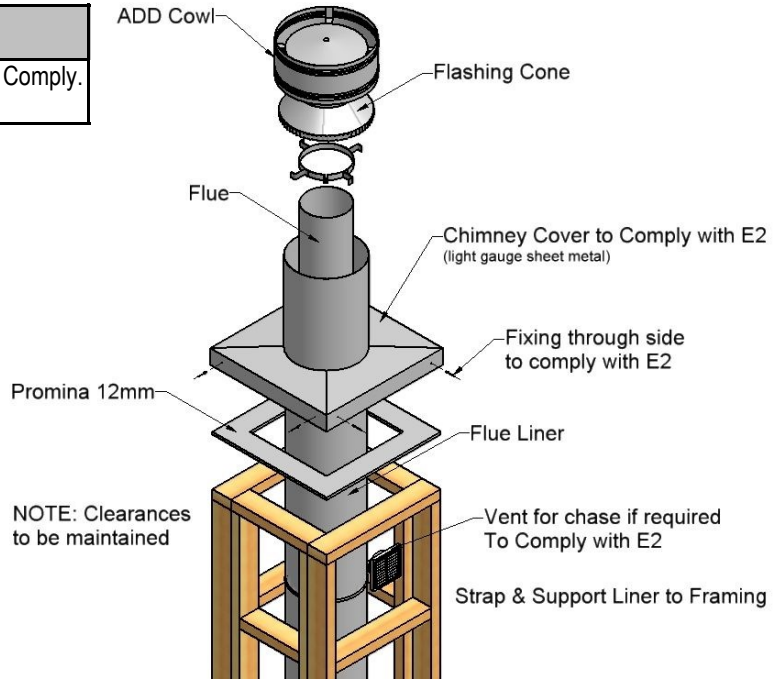

“CHIMNEY CHASE FLASHING” AND “AIR VENTILATION” OPTIONS:

VENTING THROUGH CHIMNEY CHASE

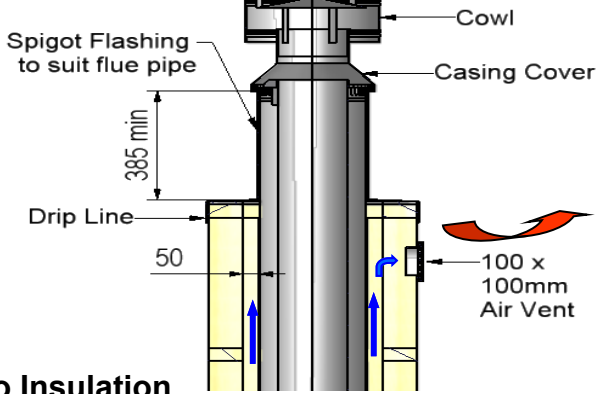

‘No Insulation under flashing’

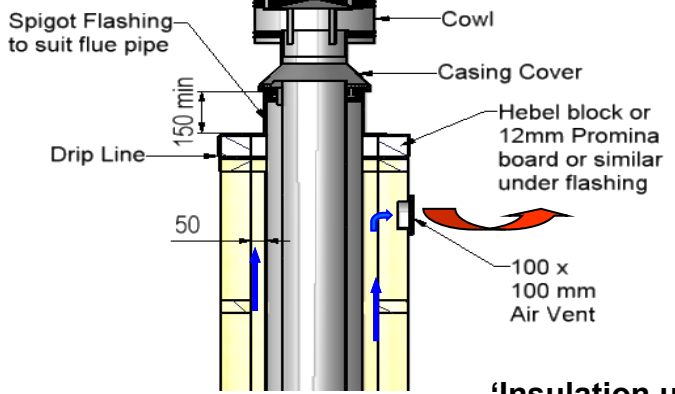

‘Insulation under flashing’

VENTING THROUGH FLASHING

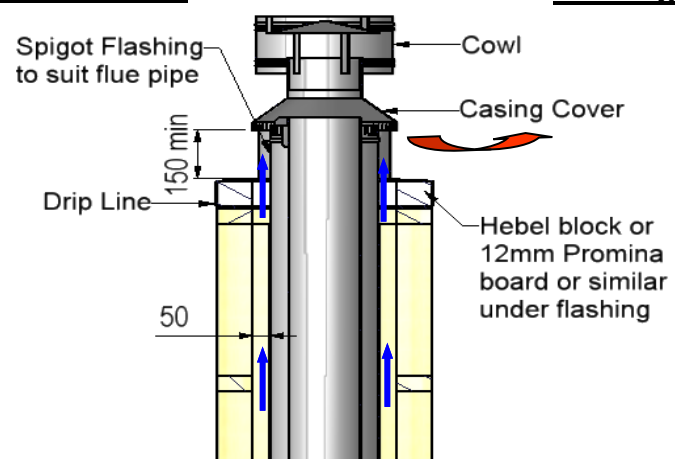
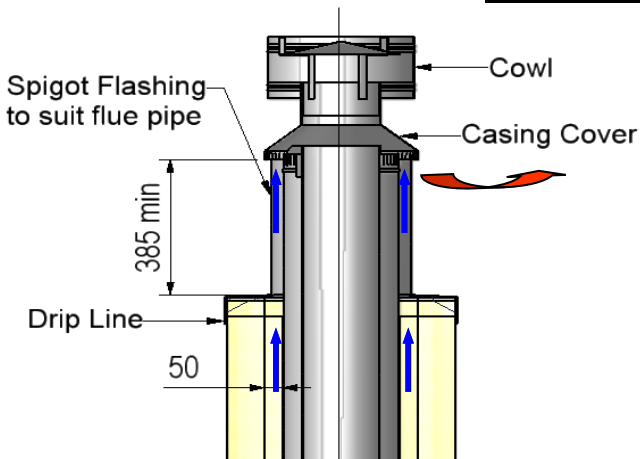

FLUE HEIGHT MINIMUM DETAILS

Note: FLUE SYSTEMS casing..
 Flue System may require to be Doubled Lined to Comply.
 Ref ASNZS:2918:2001 4.3 Flue Pipe Casing

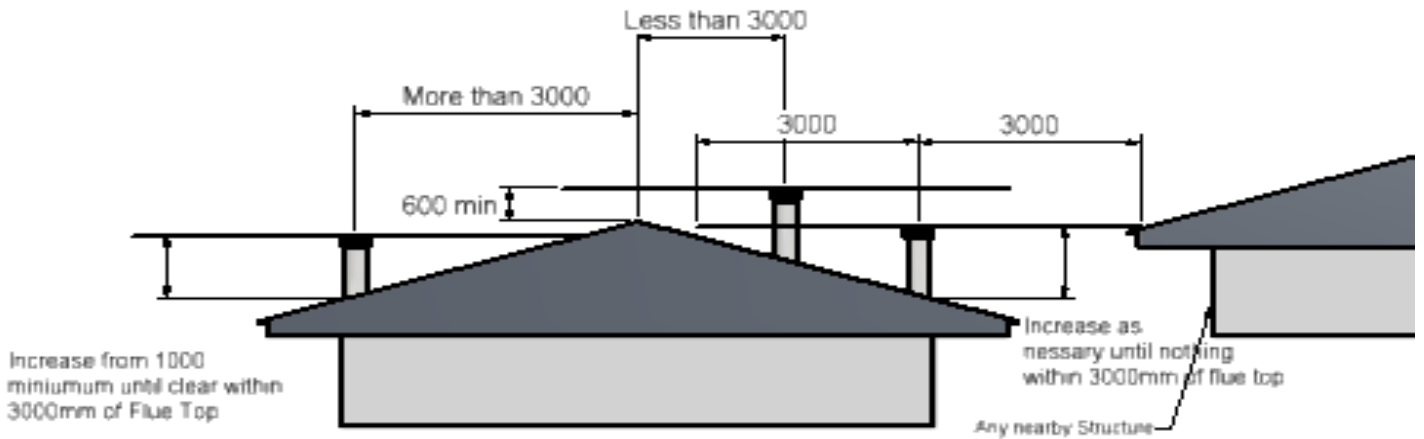

The Flue exit is to Comply to ASNZS 2918 : 2001

3D View

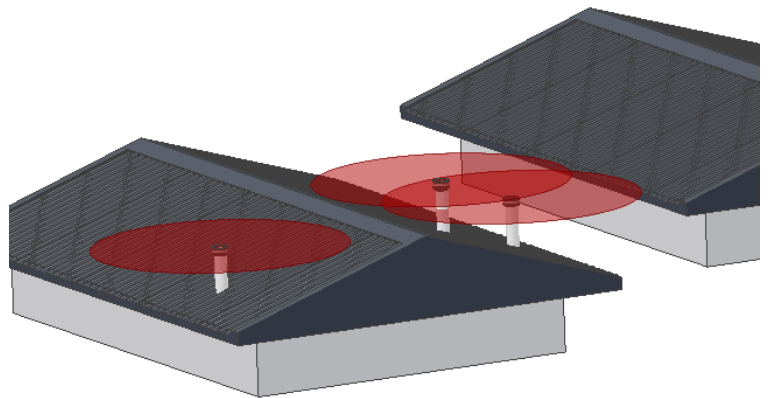

FRAME OUT AND TRIM OUT DETAILS FOR CHIMNEY CHASE

Option X – Singled Lined Flue System

Option Y – Double Lined Flue System

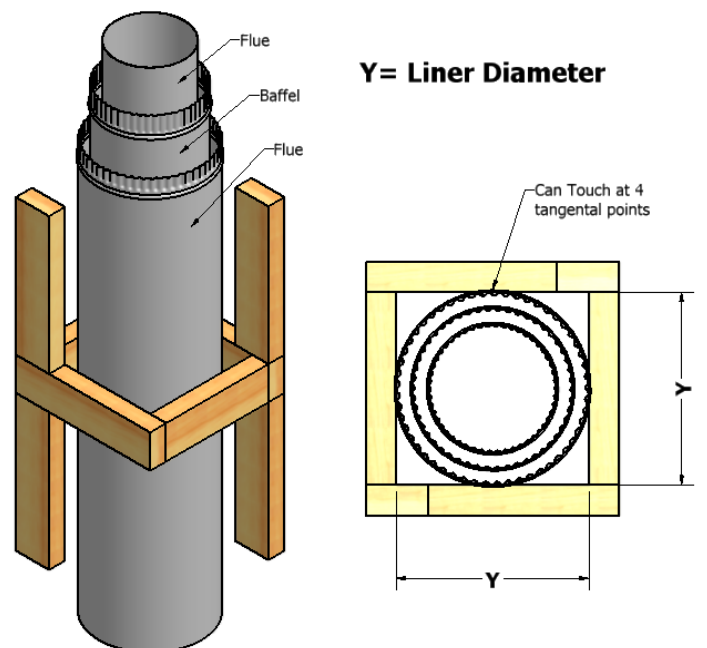
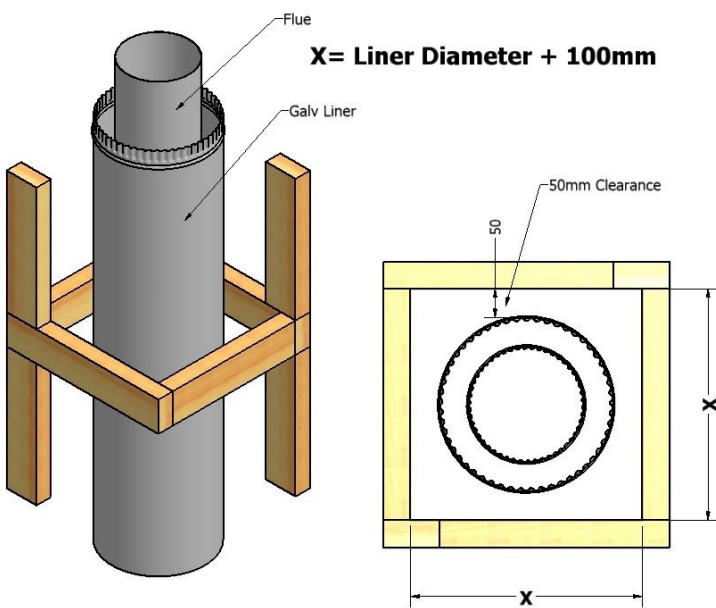

RAISED HEARTH & COMBUSTABLE MANTEL CLEARANCES

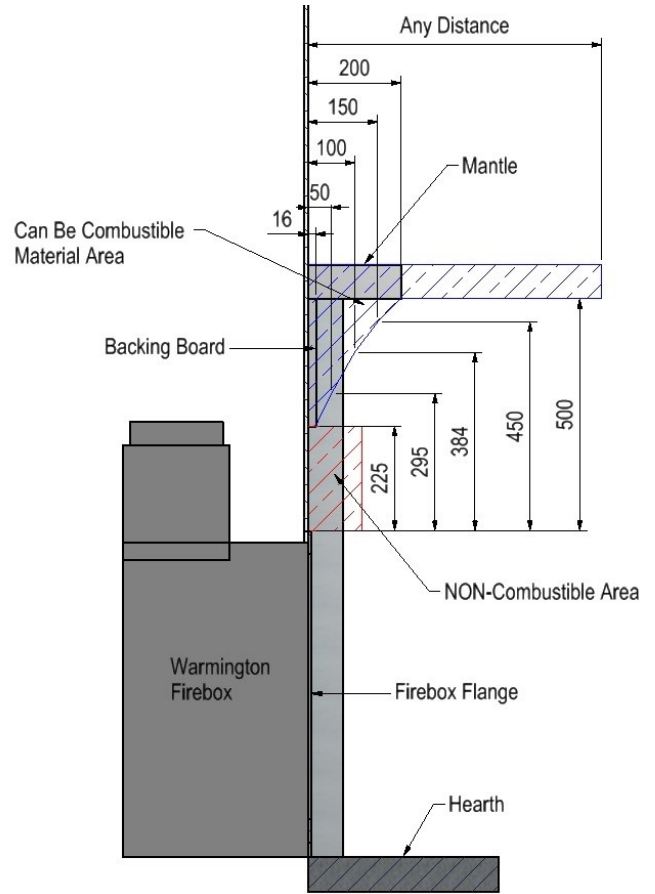
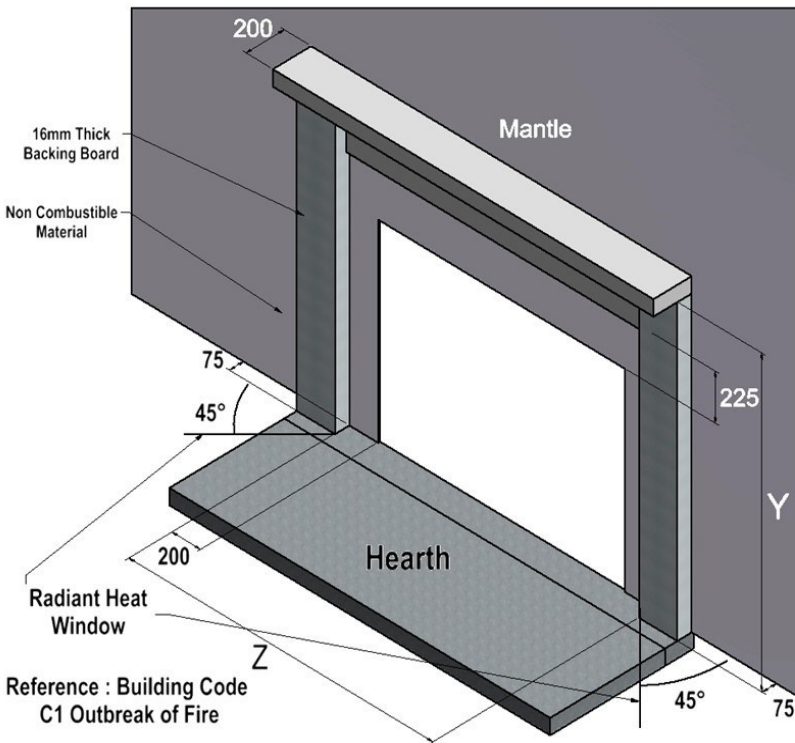

Firebox	Y	Z
SN 900	1285	1350
SN 1100	1285	1550
SN 1250	1435	1700
SN 1500	1435	1950

Important Note:
All Load Bearing Structures are to be Engineered to carry load.

RAISED HEARTH CLEARANCES

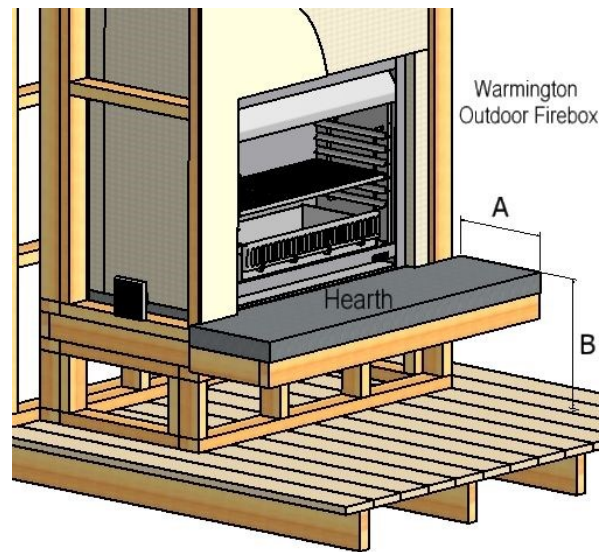
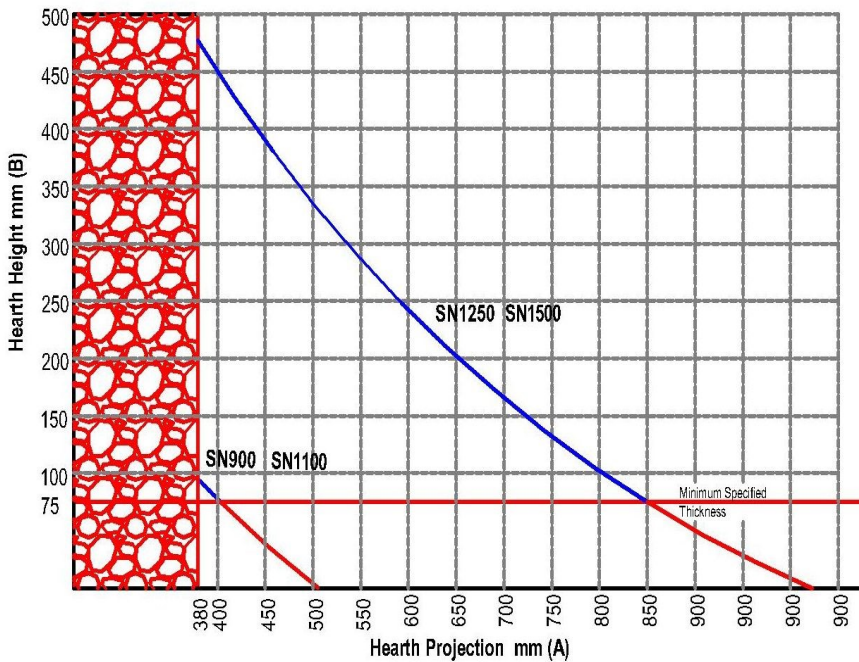

Combustible Floor

Note:
For Combustible Floors Minimum Hearth of 380mm (A) must be maintained.

GENERAL NOTES : ASNZS 2918 : 2001**NOTES:**

- Fire Operating and Maintenance instructions can be downloaded from the **Warmington** website.
- Warranty - for full details on product warranties, contact your local Authorised **Warmington** Retailer.
- Correct installation, operation and maintenance must be maintained to comply with the **Warmington** Warranty.
- The Appliance and Flue System must be installed in accordance with ASNZS2918:2001 and the appropriate Building codes.
- The flue system and fireplace is to be swept annually or more frequently if required.

IMPORTANT NOTE : TREATMENT OF COOKING SURFACES BEFORE USE**BURN OFF:**

- Before cooking on the plate or grill for the first time, burn off any residual oils or foreign matter by lighting or igniting the fire or Burner.
- ENSURE THAT THE OUTDOOR FIRE IS WELL VENTILATED WHEN LIGHTING FOR THE FIRST TIME, and operate fire on high for up to 5 minutes.
- Cooking may proceed after the surface has been carefully wiped down with a cloth or paper towel.

PREHEATING:

- It is necessary to preheat for a short time before cooking certain foods, depending on the type of food & the cooking temperature.

AFTER USE:

- Do NOT cool or put out the fire after use with water. This will damage the grate and ash pan, cause rust and could be harmful to people standing close by the fireplace.

WARNINGS:

- **WARNING: ANY MODIFICATION OF THE APPLIANCE THAT HAS NOT BEEN APPROVED IN WRITING BY THE TESTING AUTHORITY IS CONSIDERED AS BREACHING AS/NZS 4013.**
- **WARNING: DO NOT USE FLAMMABLE LIQUIDS OR AEROSOLS TO START OR REKINDLE THE FIRE.**
- **WARNING: DO NOT USE FLAMMABLE LIQUIDS OR AEROSOLS IN THE VICINITY OF THIS APPLIANCE WHEN IT IS OPERATING.**
- **WARNING: DO NOT STORE FUEL WITHIN HEATER INSTALLATION CLEARANCES.**
- **WARNING: WHEN OPERATION THIS APPLIANCE AS AN OPEN FIRE USE A SPARK SCREEN.**
- **CAUTION: THIS APPLIANCE SHOULD BE MAINTAINED AND OPERATED AT ALL TIMES IN ACCORDANCE WITH THESE INSTRUCTIONS**
- **CAUTION: THE USE OF SOME TYPES OF PRESERVATIVE-TREATED WOOD AS A FUEL CAN BE HAZARDOUS.**

NOTE: for Operating Instructions download from the website

www.warmington.co.nz



Industries 1994 LTD
PO Box 58652, Botany 2163, Auckland
www.warmington.co.nz