

**Warmington**



*the future of fires*

## gas log lighters



Lighting your fire with paper is now a thing of the past with the range of Gas Log Lighters from Warmington.

Simply press the button and the gas flare, or rail burner will flare for around 10 minutes, lighting the wood and starting the fire automatically.

### Features and Benefits:

- Light your fire with minimal effort.
- Auto timer function.
- Available in either LPG or natural gas.
- Made in New Zealand
- A range of styles to choose from.





Warmington have a range of gas log lighters with various options available for fitment into ash pans or open grates.

Your Warmington Retailer can help to find the best option for your fire.

### Gas Flare

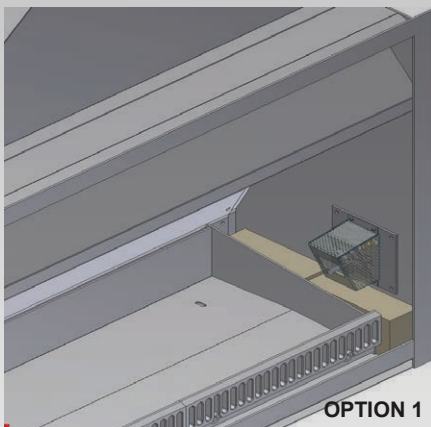

### Rail Burner (ash pan)

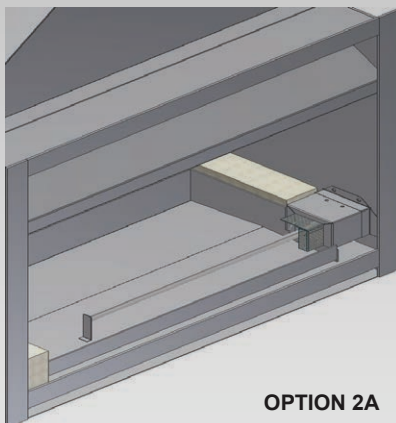

### Rail Burner (grate)

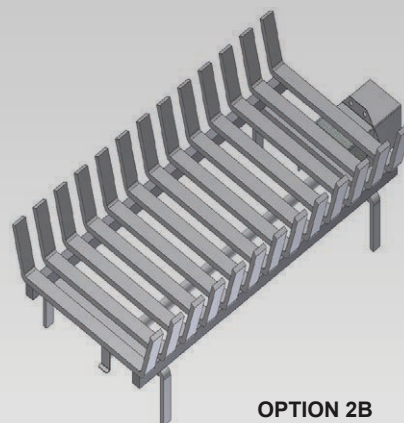

### Tee Bar Rail

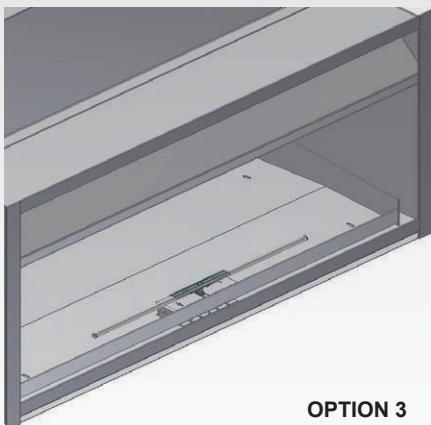

### Trad Tee Bar Rail

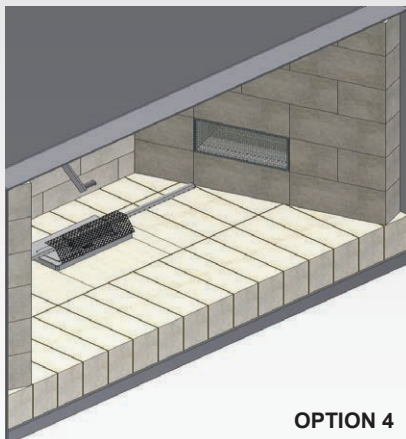

Gas Log lighter needs to be fitted by a:

1. Registered Gasfitter and must comply with NZS5262/5261:2003.
2. Registered Electrician and must comply with the Electricity Regulations 1993.

Please refer to the install Specifications on the Warmington website.



Available from Authorised Agents nationwide, or phone: 09 271 0891 for more information.



[www.warmington.co.nz](http://www.warmington.co.nz)

