



## evoque fire | 1300

The evoque fire has been designed to complement both modern and traditional interiors. The large glass door provides an unrestricted view of the fire so you can sit back and enjoy the warmth and ambience that only a wood fire can give.

Using innovative technology, the evoque is the ultimate in style and performance, engineered to deliver maximum heat and efficiency.

### **features and benefits:**

- Maximum heat up to 25kw
- Heat diffusion system
- Large firebox
- Vermiculite firebricks for heat retention
- Fully retractable door for easy access
- Proudly crafted and manufactured in New Zealand







The evoque wood fire uses a controlled air supply, which ensures wood burns cleanly and efficiently, maximising the amount of heat produced and keeping wood consumption, ash and soot to a minimum.

The door is designed to slide up for an uninterrupted view of the fire, and swing open for easy loading.

**Note:** The Evoque 1300 is not clean-air approved. Please check with your Local Council for current regulations.

**THE DETAILS BELOW ARE A GUIDE ONLY AND ARE NOT TO BE USED FOR INSTALLATION**

Description		EV 1300
Heat cell width	G	1552
Heat cell height	H	2170
Heat cell depth	I	980
To centre of flue	J	624
Flue diameter	K	300
Liner diameter	L	400
Opening width	M	780
Opening height	N	1128
Height from floor to opening	O	322

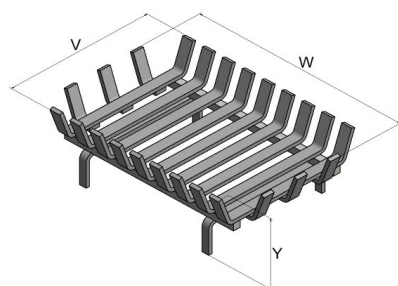

Description		GRATE
Grate Depth	V	410
Grate Width	W	605
Grate Height	X	195

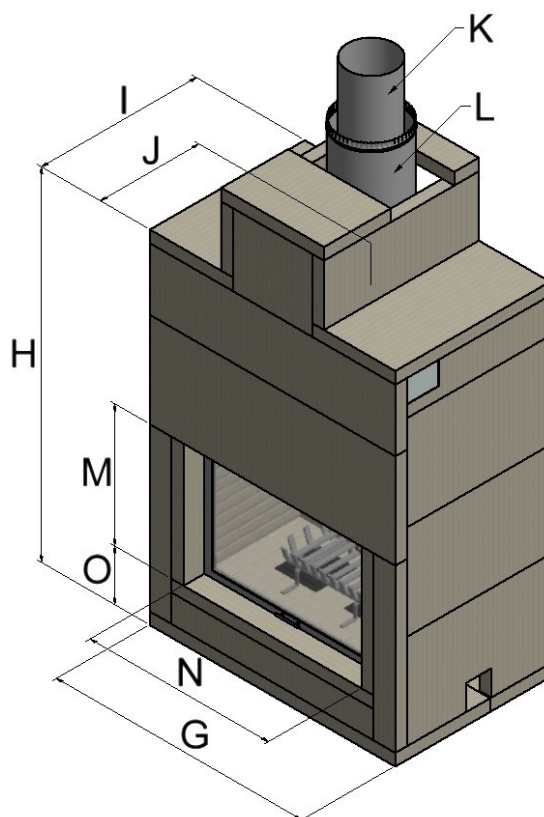

Available from Authorised Agents Nationwide, or phone: 09 271 0891 for more information.



[www.warmington.co.nz](http://www.warmington.co.nz)