

Debonaire DUPLO 1200-1600-2000-2400-2800

Custom Fire DUPLO — Gas Burner Installation Instructions

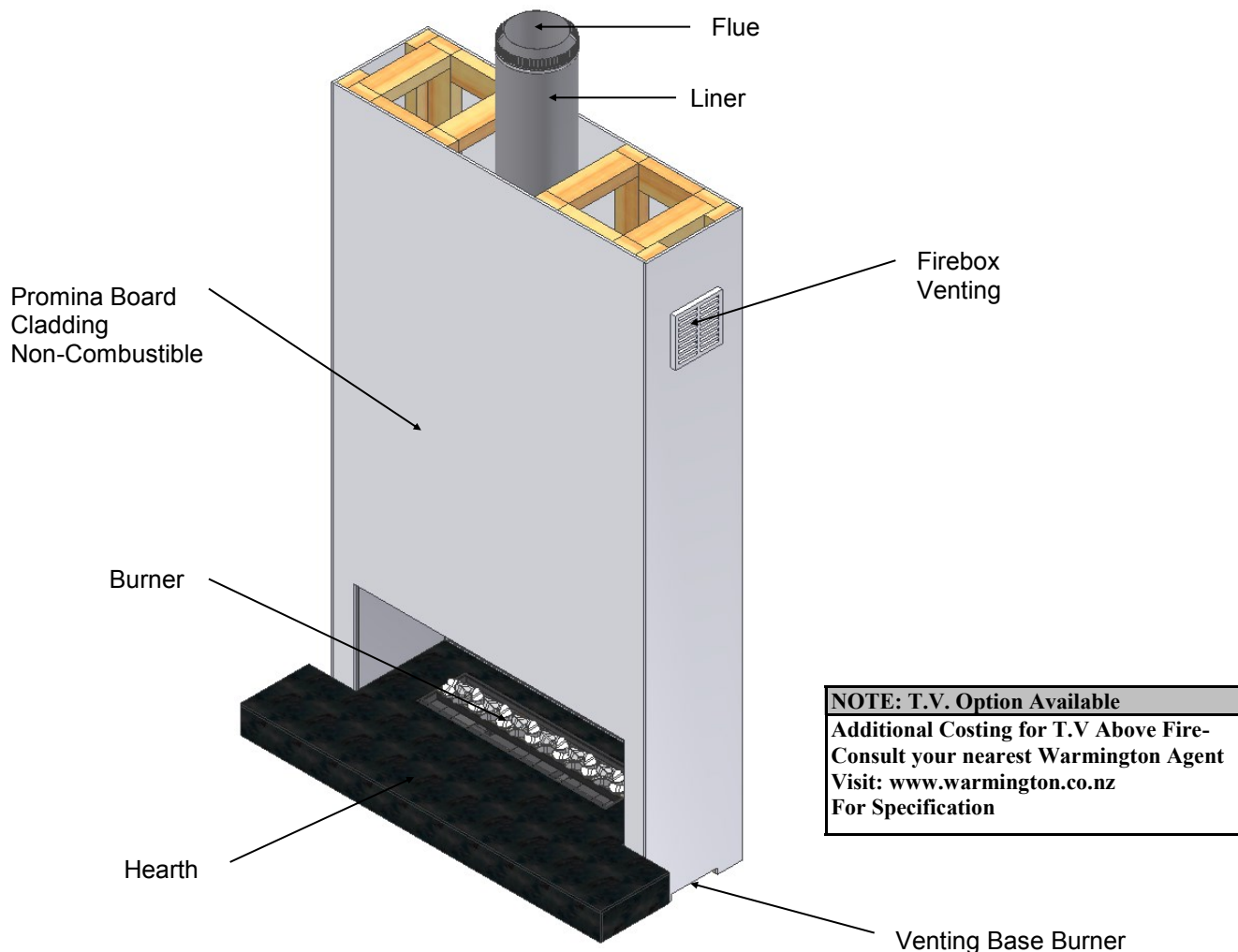

Related documents

Fire and flue system installation, and instructions to comply with NZS 5601.1:2013, 3645.1(Int):2010, 3645.2(Int):2010, 5266:2014, 2918:2001.

The fireplace is constructed and tested to comply with NZS 4558(int):2013 “Decorative gas log and other fuel effect appliances”.

Keep these instructions for further reference. Ensure that you have the correct and current installation details for the Warmington fireplace.

Installation

The Warmington unit is to be installed by a certified Warmington installer or an approved NZHHA installation technician.

See www.homeheat.co.nz/members for a certified NZHHA SFAIT Installer in your area.

A licenced certified gas fitter and licenced electrician are required to run power and gas supplies as required to the unit and any commissioning as part of the installation process. The heater must be installed according to these instructions and in compliance with all relevant building, gas fitting, electrical and other statutory regulations.

IMPORTANT

Read all the instructions carefully before commencing the Installation. Failure to follow these instructions may result in a fire hazard and void the warranty

Due to continued product improvement, Warmington Ind LTD reserves the right to change product specifications without prior notification.

POINTS TO CONSIDER PRIOR TO INSTALLATION

Location of the fire. Open fires are better located at one end of a room or area, as they project the heat away from their opening.

Venting to the cavity.

This air is to allow the cavity to vent the warm air. This warm air helps keep the fire and flue system from getting too cold. If the flue and fire get too cold the system may soot and require cleaning. Each fire has different ways of venting the cavity.

The Topography of the land .

The slope and position of the land in relation to the home has a bearing on how the wind will interact with the fire and flue system. Care needs to be taken to ensure that the flue termination is in the correct position to maximise performance.

The Prevailing Wind.

Care needs to be taken to ensure that the flue termination is in the correct position as wind and gusts that hit the flue and cowl system may overcome the cowl and draft back down the flue into the home. This can be a combination of down draft and high pressure.

Hearth and plinth:

The height of the hearth off the floor. The finishing that is to be used on the hearth is to be allowed for at the design stage.

Positioning of the Flue system:

Flue Systems are to comply with the appropriate standard.

Flue And Fire Clearance:

To be maintained to the manufacturer's Instructions. Reference the appropriate standard.

Pressure Differential, Venting & External Air into the Building :

All fires need air to burn and draw correctly, Kitchen Fans, Air Conditioning units, High Wind Zones, Naturally forming Draft spaces, can all have an effect on the pressure difference from inside the building to the outside. A lower pressure in the building may induce a draft down the flue system and back into the building causing the fire to smoke or spill into the building. **Care needs to be taken at the design and installation stage to adequately vent the building, or some mechanical system to ensure that there is always a neutral or positive pressure at the fireplace and a negative pressure at the flue outlet.** This will ensure that the draft in the flue system is always to the outside.

"CAITEC AIR" the limits and requirements. See details in these Spec's, on www.warmington.co.nz or contact your local Agent.

Wind Noise:

You may encounter wind noise in some installations. It is recommended to use an enclosed chase with a chimney pot to help reduce noise. There will always be some noise from the flue systems of all fireplaces.

INSTALLATION ORDER OF OPERATIONS

Prior to Construction and Installation

Important Notes:

1. **Consult a licenced certified gas fitter for correct gas installation.**
2. Install to current standards.
3. Install to manufacturer's specifications.
4. All new installations require a permit.
5. Allow for gas supply to heat cell at the rear, and power supply to the rear if required.
6. For special requirements concerning materials (timber mantle and surrounds) within close proximity of Warmington products, please contact your local Warmington Technical Consultant.

Stage 1: Frame Construction Procedure by Builder.

1. Mark out flue centre.
2. Mark out heat cell clearance requirements.
3. Build timber framing to heat cell clearances and chimney chase clearance requirements.
4. Ensure that front face of heat cell clearance alcove is left open and unframed to enable installation of the firebox. The chimney chase is left unlined for installation of the flue.
5. Construct plinth only, to required height. *

Stage 2: Install Procedure by Certified "Warmington Installer" or Certified Person (Gas Fitter / Plumber)

1. Fit fire to plinth.(Ensure gas supply line is fed through firebox.)
2. Fit flue system.
3. Fit cowl and flashing system.
4. Fit vents to heat cell alcove and chimney chase, to cool the heat cell and ensure efficiency of CAITEC Technology.

Stage 3: Finishing Procedure by Builder.

1. Construct hearth to required thickness. *
2. Finish framing of heat cell alcove.
3. Close in heat cell alcove and chimney chase.
4. Finish heat cell alcove and hearth to customer's requirements (e.g. paint / tiles).
5. * **Note: Certified installer can install hearth and plinth.**

Maintenance.

Visually inspect fireplace and flue system.
Ensure that firebox is operated according to manufacturer's instructions.

Due to continued product improvement, Warmington Ind LTD reserves the right to change product specifications without prior notification.

CUSTOM GAS FIREBOX DIMENSIONS

Description		1200	1600	2000	2400	2800
Firebox Overall Width	A	1200	1600	2000	2400	2800
Firebox Overall Height	B	1800	1800	1800	1800	1800
Firebox Overall Depth	C	390	390	390	390	390
Window Width	D	1130	1530	1930	2330	2730
Window Height	E	400	400	400	400	400
Height from Base	F	400	400	400	400	400
Convection Vent Dia	G	100	100	100	100	100
Flue Dia.	H	200	275	2 x 200	2 x 250	2 x 250
Flue Liner Dia.		250	325	2 x 250	2 x 300	2 x 300

**HEARTH REQUIREMENTS
TO BE PLACED ON MASONRY FLOOR**

Minimum Flue Height	
Flue Height	3600
Measured From Top of Adaptor	3600

TOP

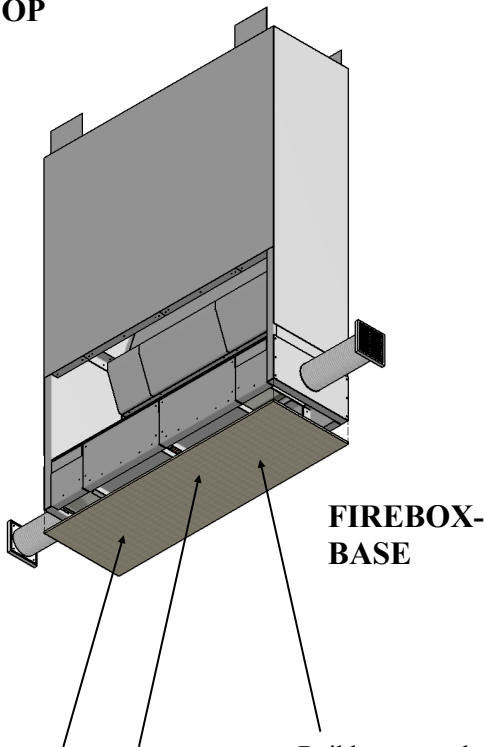

Seismic restraint
Secure firebox through anchor points provided

Builder to supply Non-Combustible Base Compressed sheet To Act as Seal to Base

Seismic restraint
Secure firebox through anchor positions through Base & through bracket at Top of Fire

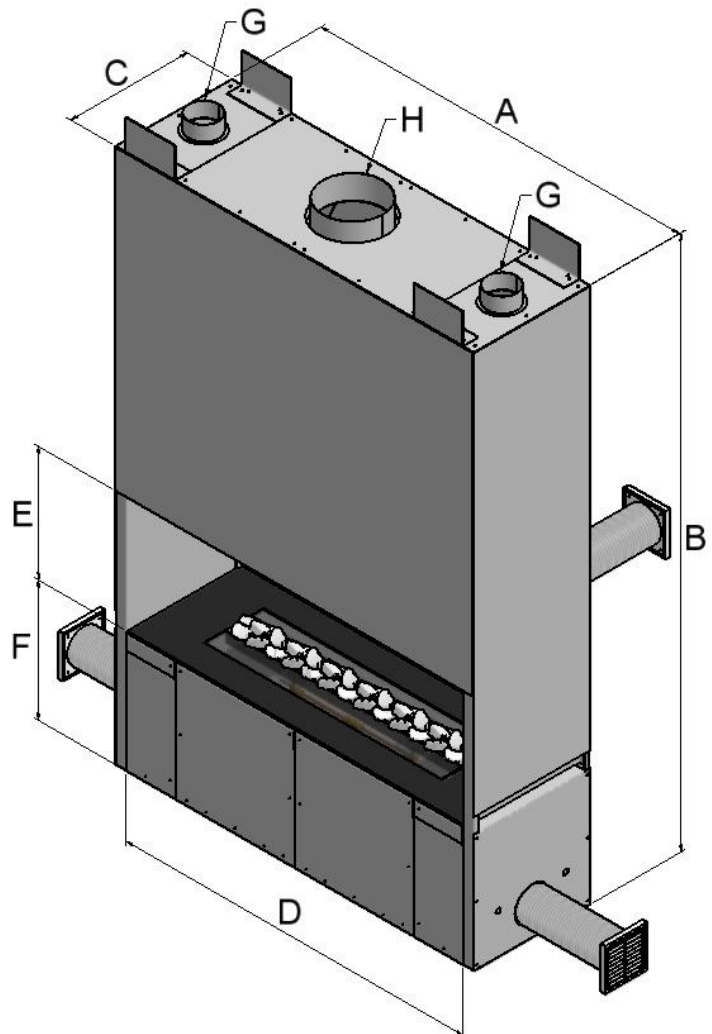

Due to continued product improvement, Warmington Ind LTD reserves the right to change product specifications without prior notification.

MINIMUM ALCOVE CLEARANCES

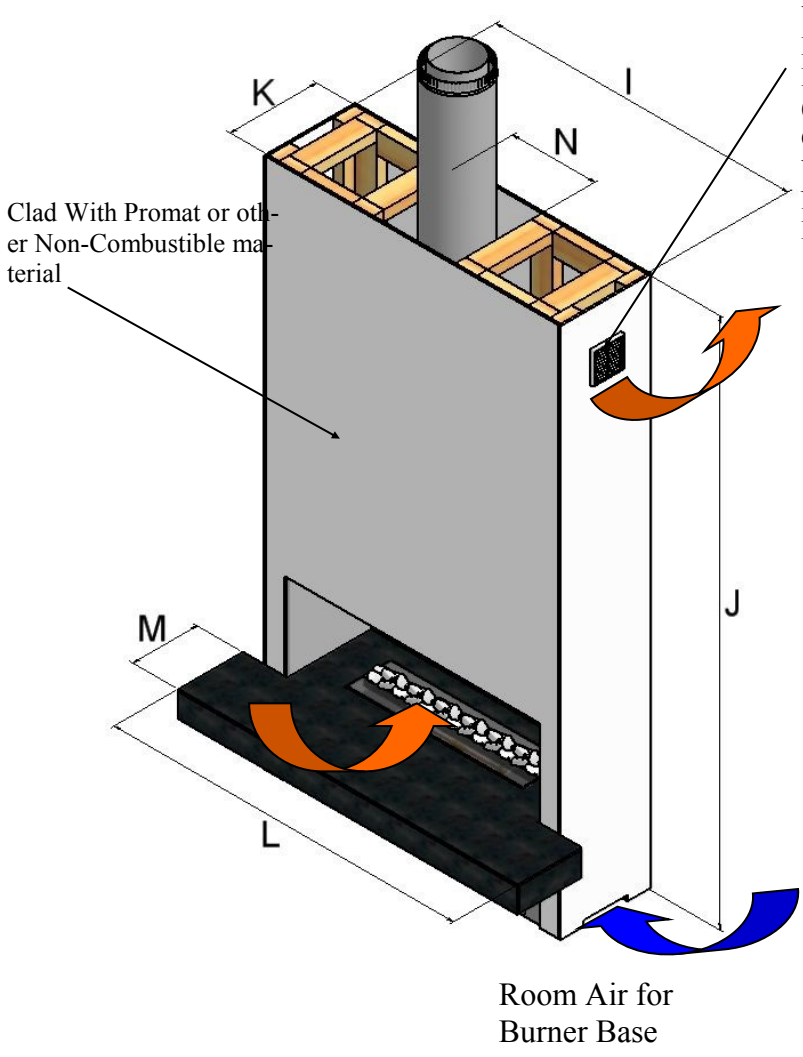

Warm Air Return to Room (Optional Caitec) Vent Grill NOT Provided

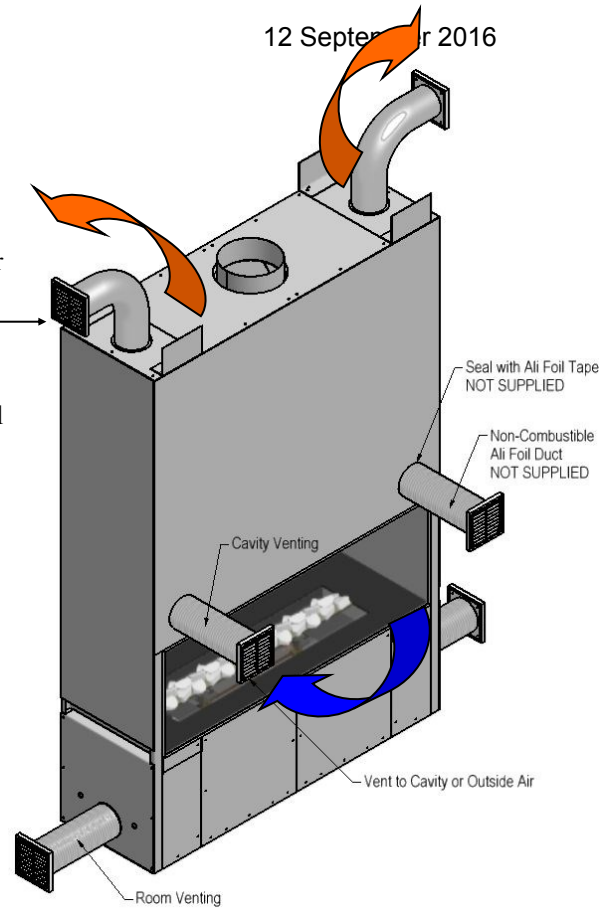

FRAMEOUT DETAIL

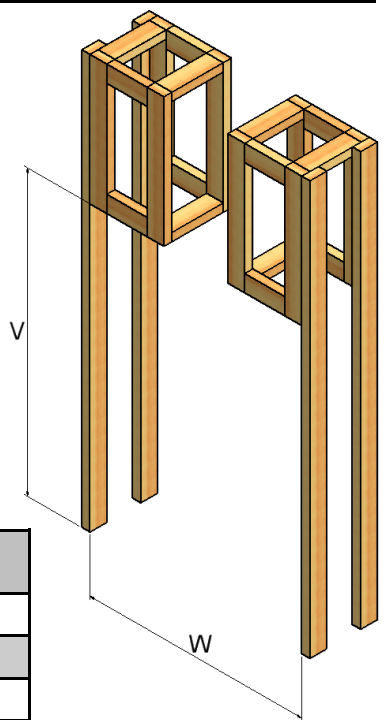

Description		1200	1600	2000	2400	2800
Overall Timber Width	I	1317	1717	2117	2517	2917
Overall Timber Height	J	2400	2400	2400	2400	2400
Overall Timber Depth	K	390	390	390	390	390
Hearth Width	L	1530	1930	2330	2730	3130
Hearth Depth	M	300	300	300	300	300
Flue Cavity Depth	N	350	425	950	1400	1800
Timber Opening						
Opening Height	V	1850	1850	1850	1850	1850
Opening Width	W	1223	1623	2023	2423	2823

Due to continued product improvement, Warmington Ind LTD reserves the right to change product specifications without prior notification.

VENTING THE BURNER CAVITY ONLY - General

IMPORTANT NOTE

The Burner and the Burner Base are to be Vented into the same air space. E.G. the Room that the Burner is taking its air from must be the same as the position of the Vent for the Burner Base.

The Burner Base must be Vented separately to the Alcove and Flue System
 - This is to Avoid the Flames and Heat being drawn from the Fire, Down into the Burner

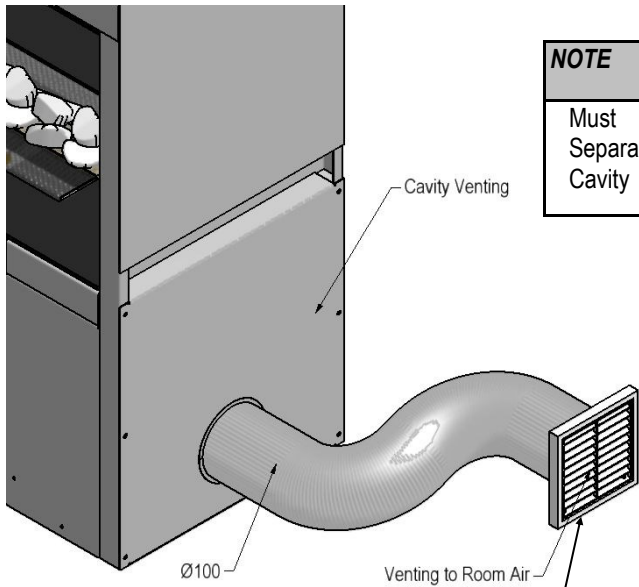

NOTE
 Must be Vented Separately to the Cavity

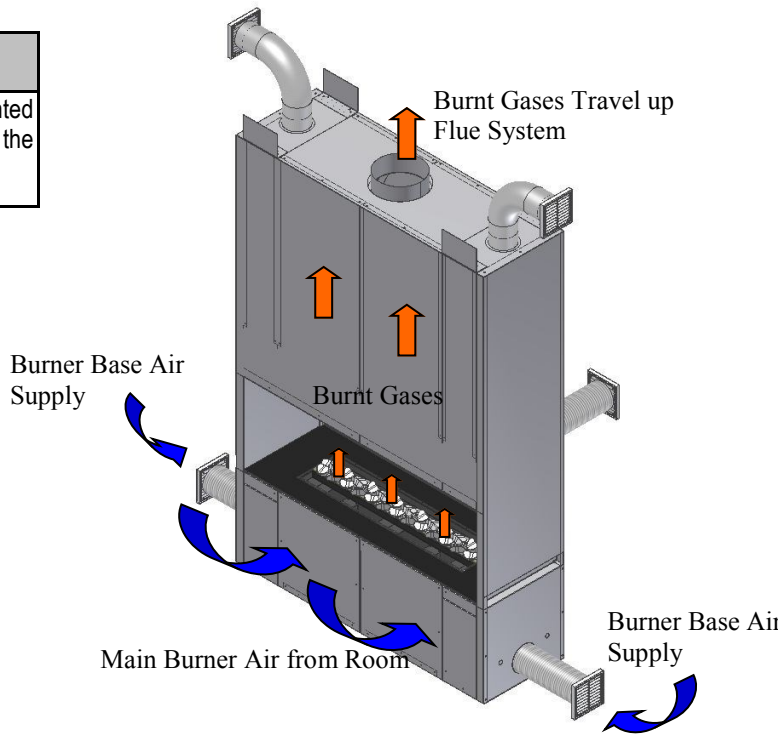

From the Room that the Burner takes its Air from.

VENTING THE CAVITY & VENTS FOR CONVECTION AIR - General

The Cavity Venting will allow the Air to move through the Heat exchanger Returning Warm Air to the Room.

NOTE
 This Cavity Air Must Not be Vented to the Burner Cavity

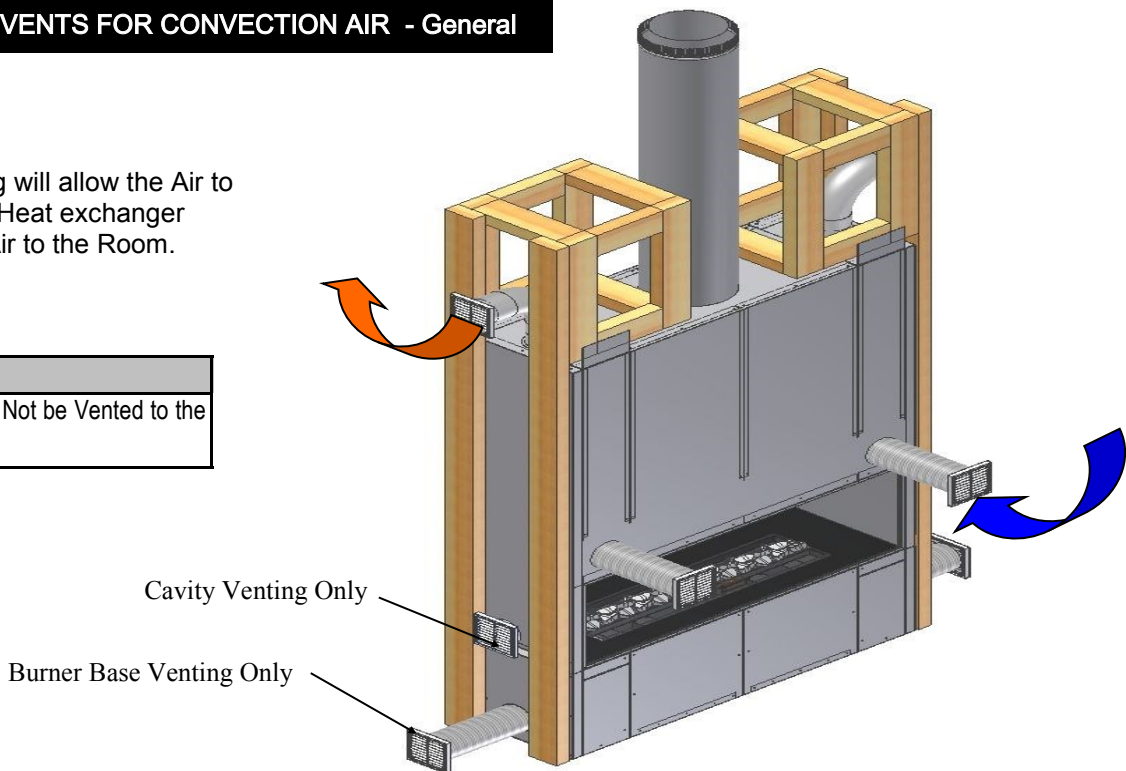

Due to continued product improvement, Warmington Ind LTD reserves the right to change product specifications without prior notification.

FIREBOX INSTALLATION

This is a general installation guide only – Contact a “NZHHA Installer” or Gas Fitter for Installation Advice.

1. All the dimensions are minimums
2. Fit the Plinth into position in the Cavity. If onto a wooden floor ensure that an insulating plinth is fitted as per the specifications. Ensure that the plinth is elevated to allow for finishing on the hearth. (See Hearth and plinth details)
3. Fit the firebox into the Cavity. Bolt the fire box to the plinth or through to the floor with the bolting point provided on the Left and Right hand sides of the fire box (seismic restraints).
4. Install the flue system.

HEARTH & PLINTH CONSTRUCTION DETAILS

IMPORTANT NOTE :

Note: Hearth and Plinth Construction.
 Plinth to be off set above hearth by the hearth finishing's (e.g. tiles / granite / plaster / etc)

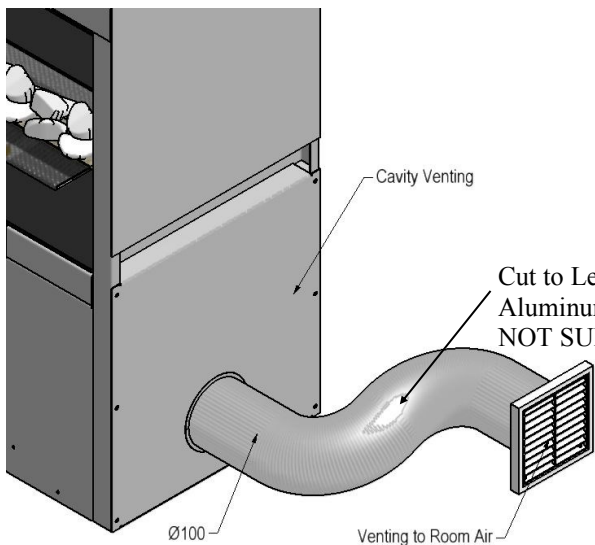

Note:
 Vent & Duct
 NOT SUPPLIED

Vent NOT SUPPLIED

300mm Minimum Projection

10mm Minimum
 Non-Combustible Material

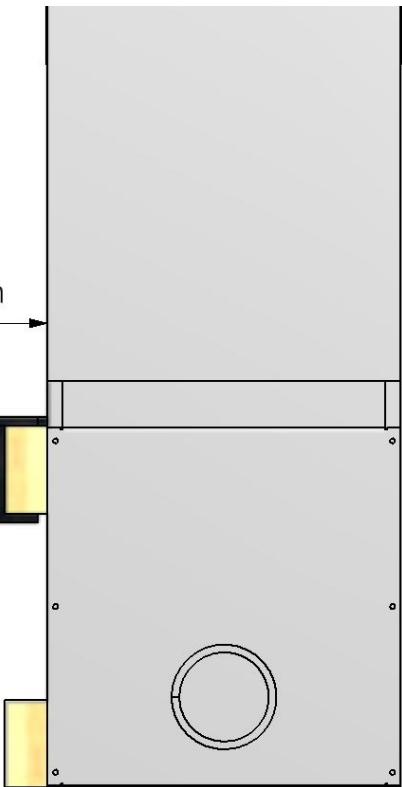

Note:
 Hearth to be Constructed as
 Per Specification

Due to continued product improvement, Warmington Ind LTD reserves the right to change product specifications without prior notification.

PLAN

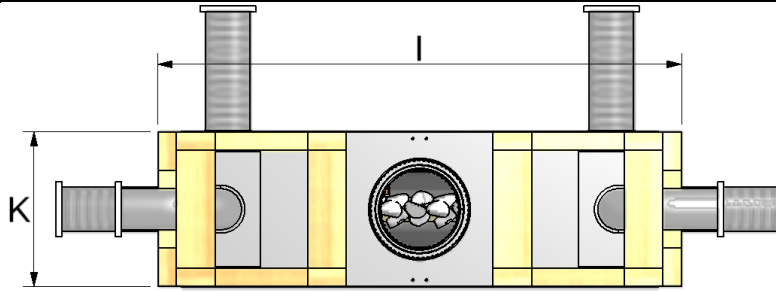

FRONT ELEVATION & CROSS SECTION

Description		1200	1600	2000	2400	2800
Window Height	E	400	400	400	400	400
Base Height	F	400	400	400	400	400
Outside Framing	I	1317	1717	2117	2517	2917
Framing Height	J	2400	2400	2400	2400	2400
Framing Depth	K	390	390	390	390	390

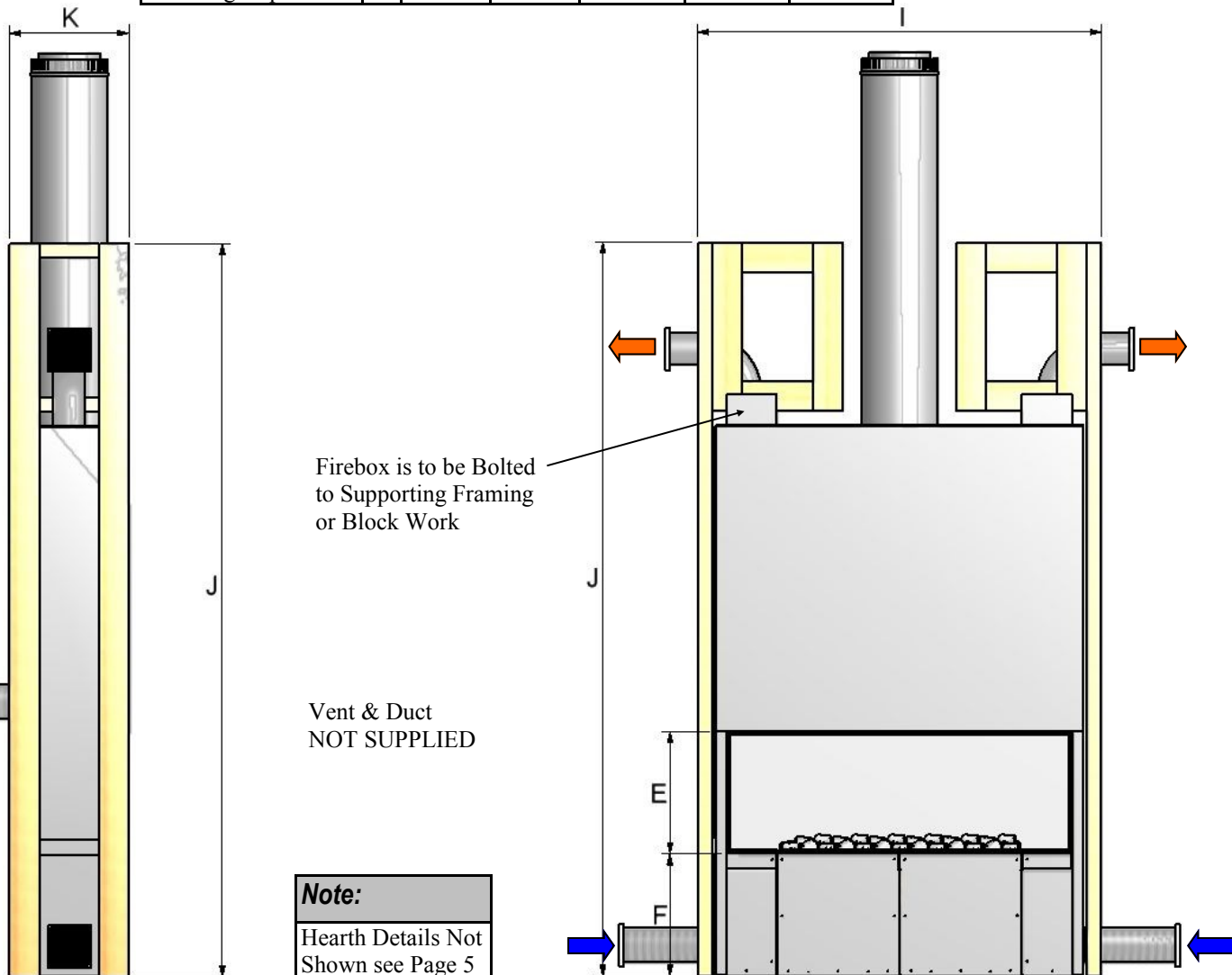

Due to continued product improvement, Warmington Ind LTD reserves the right to change product specifications without prior notification.

FLUE DETAILS DIMENSIONS Double Flue System

Minimum Flue Height	
Flue Height	3600
Measured From Top of Adaptor	3600

Flue details	No:	1200	No:	1600	No:	2000	No:	2400	No:	2800
Cowl	1	200	1	275	2	200	2	250	2	250
Spacer	3	200	3	275	6	200	6	250	6	250
Flue Diameter	3	200	3	275	6	200	6	250	6	250
Liner Diameter	3	250	3	325	6	250	6	300	6	300
Bottom Spacer	1	200/250	1	275/325	2	200/250	2	250/300	2	250/300

ANY OPENING OR CAVITY MUST BE MORE THAN 1 METER AWAY FROM WHERE EXHAUST GASES ARE PRESENT.

NOTE: Ensure that a Standard Tested Warmington Flue system is used on Warmington fires.

GENERAL FLUE SYSTEM INSTALLATION GUIDE ONLY (MAY VARY ON SITE INSTALL)

This is a general installation guide only – Contact a “NZHHA Installer” for Installation Advice.

1. Install the first length of flue pipe with the crimped end down, inside the Adaptor collar, ensure that the flue pipe is sealed into the collar with exhaust sealant. Rivet the flue in 3 places around the Adaptor collar. Place a bottom spacer around the flue pipe approximately 150mm above the adaptor collar. Secure in position by tightening the screw and nut.
2. Install the second length of flue pipe with the crimped end down and fit by riveting in at least 3 places around the flue pipe joint. Ensure that the flue is sealed into position with sealant.
3. Install the first section of flue pipe liner with the Crimped end up, over the flue pipe and over the spacer that is fixed to the flue pipe. This spacer will keep the liner concentric about the flue pipe.
4. Position flue spacer at the flue pipe joint for every length of “Flue pipe” and “Liner”. Repeat the Steps from 1 – 4 to the installed required height of the flue system. The flue system is to comply with the current standards.

- a “the flue pipe shall extend not less than 4.6m above the top of the floor protector.”
- b “the minimum height of the flue system within 3 m distance from the highest point of the roof shall be 600mm above that point.”
- c “the minimum height of the flue system further than 3 m from the highest point of the roof shall be 1000mm above the roof penetration.”
- d “no part of any building lies in or above a circular area described by a horizontal radius of 3 m about the flue system exit.”

IF FLASHING CONE NEEDED

1. **NOTE:** The last length of flue pipe needs to extend past the liner so that when the “top spider” and the “Flashing cone” are fitted, that the “flashing cone” and the “flue pipe” are **flush**, or that the “flue pipe” is **5mm lower** than the “Flashing cone”.
2. Fit the “Top Spider” into position, ensure that the legs of the spider are fitted inside the liner and that the spider is positioned hard down onto the liner and tighten with the screw and nut.
3. Place the “Flashing cone” over the “flue pipe” and press hard down onto the “Top Spider”. (Note that the “Flue pipe” and the “Flashing Cone” are either flush or the “Flue pipe” is 5mm Lower than the “Flashing cone”.) Ensure that the “Flashing cone” is clear for the venting from the “Liner” and the “flue pipe”.
4. Fit the “Cowl” to the top of the flue pipe. The “Cowl”, “Flashing cone”, and the “Flue pipe” can be secured to each other with the uses of a stainless steel self tapping screw. This will allow the “Cowl” to be removed for cleaning.
5. Flue system may require Bird Proofing due to the installation and locations, discuss this with your installer for the best advice.
6. If the Flue system is installed into a “Chimney Chase”, allow for air vent as close to the top of the chase as practical, or allow venting through the “Chimney Chase Flashing”. A “Venting Flashing cone” and a 25mm gap around the Liner with a “Venting Flashing Cone-Spider” can be used. Ref : to Figures In this Specification

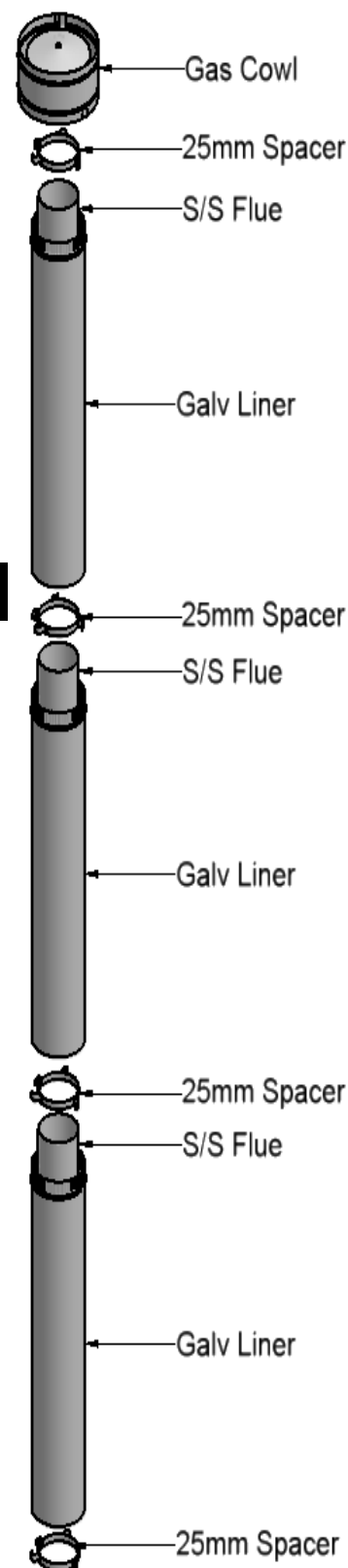

Due to continued product improvement, Warmington Ind LTD reserves the right to change product specifications without prior notification.

FLUE PENETRATION Vented through Alcove (Single lined Flue System)

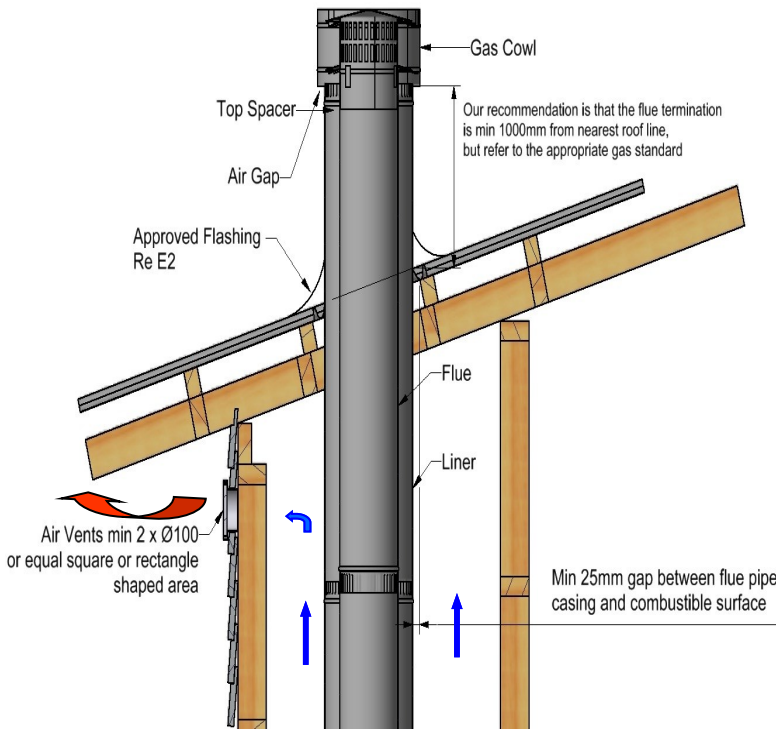

FLUE PENETRATION Vented through Alcove (Double lined Flue System)

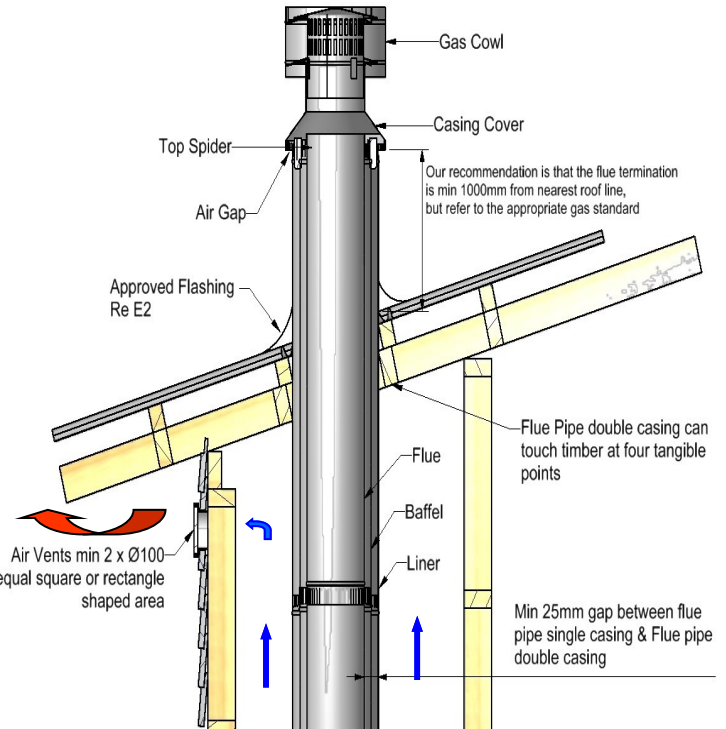

FLUE PENETRATION Vented through Top Flashing

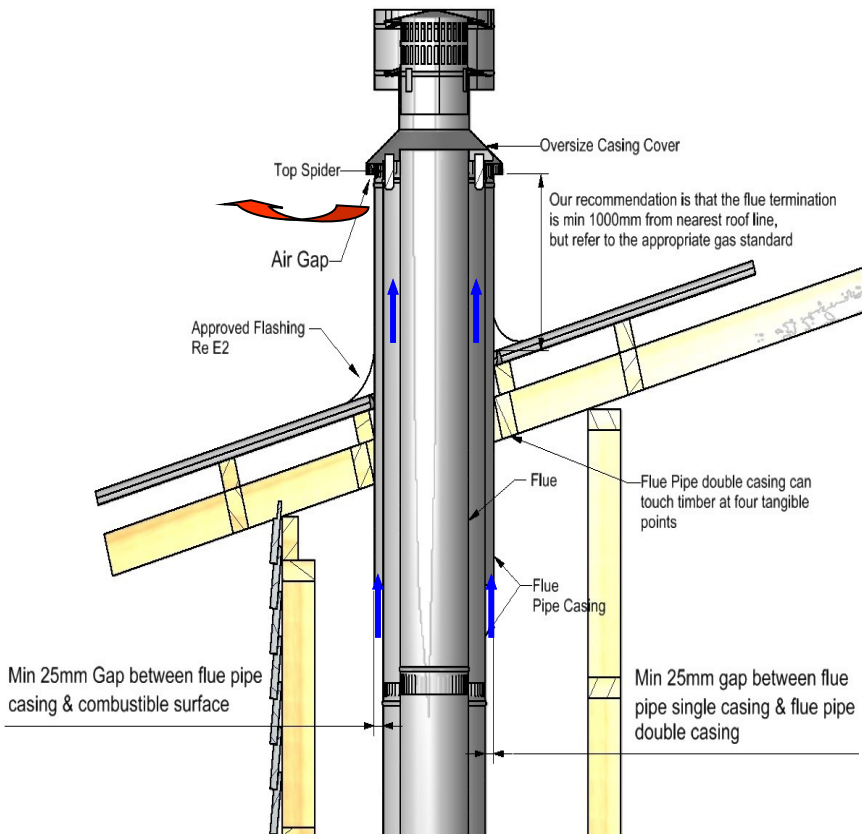

Note:

External requirements
Refer to relevant standards.

Install flue system to relevant standards.

When using a rubber or bitumen flashing (butynol, bectite) an additional flue pipe baffle is required.

All external air vents & ceiling penetrations must be bird proofed with permanently fixed screens.

All flashing to comply with E2.

All external air vents and ceiling penetrations are to be Vermin and Rodent proof.

Test Report Number	Date of Report
04/1039	20 th July 2004
04/1040	20 th July 2004
04/1041	20 th July 2004

Due to continued product improvement, Warmington Ind LTD reserves the right to change product specifications without prior notification.

CHIMNEY CHASE FLASHING DETAILS SETTING ADD GAS COWL HEIGHT

General Chimney Chase Flashing Lay Out

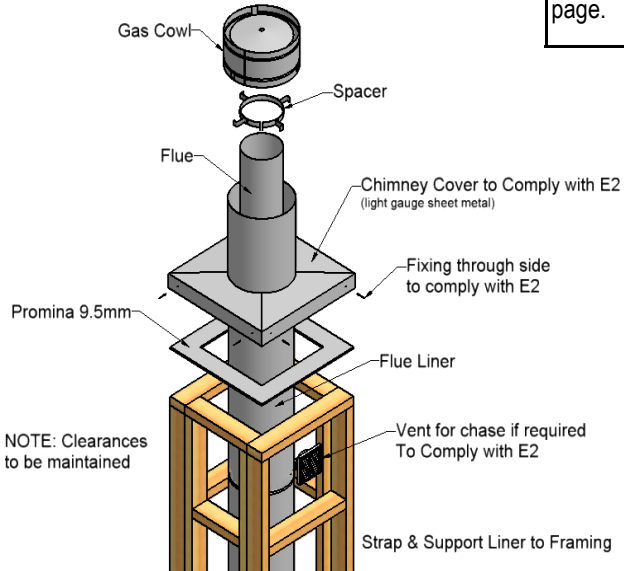

Note:
Flashing Spigot height is determined by the Insulation that is fitted under the Flashing ... See Details at bottom of page.

SETTING COWL to FLUE
ADD Gas Cowl is to be set as shown and is in accordance with Foley's Industries LTD.

STEP 1

Flues are to be set flush to the same height, Spacer set at approx 80mm low.

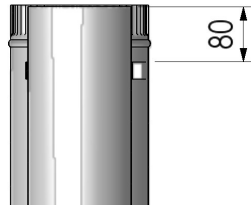

STEP 2

ADD Gas Cowl slides inside the flue, sitting on the swage, leaving a 10mm Air gap from cowl to liner, screw to secure

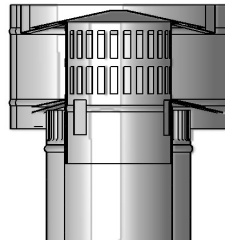

"CHIMNEY CHASE FLASHING" AND "AIR VENTILATION" OPTIONS :

VENTING THROUGH CHIMNEY CHASE

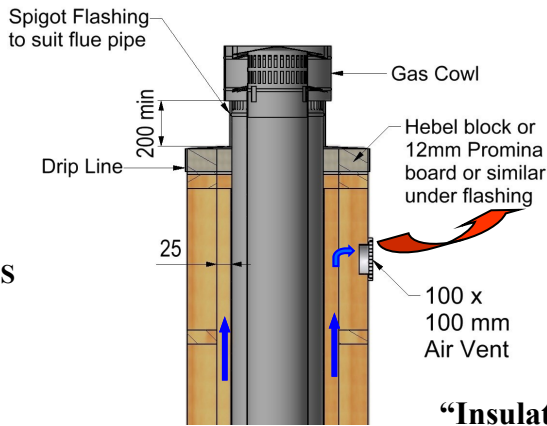
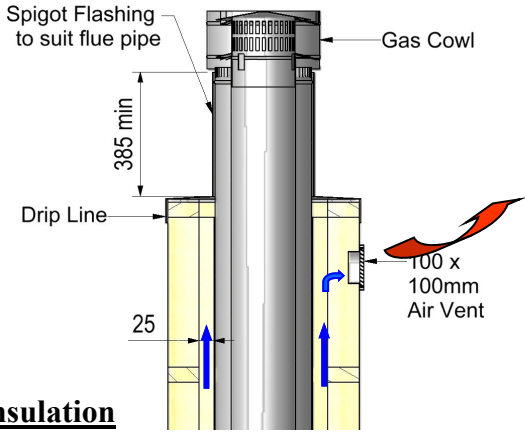

"No Insulation under flashing"

"Insulation under flashing"

VENTING THROUGH FLASHING

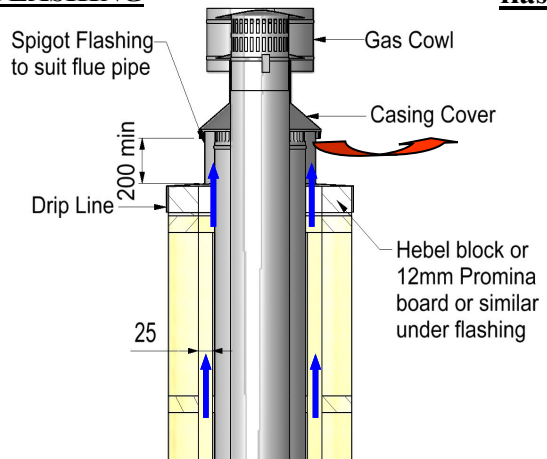
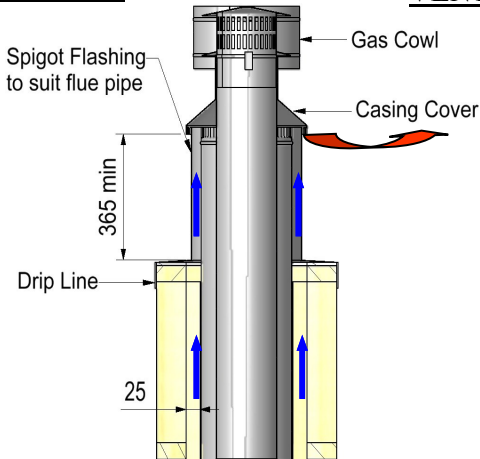

Due to continued product improvement, Warmington Ind LTD reserves the right to change product specifications without prior notification.

FLUE HEIGHT MINIMUM DETAILS

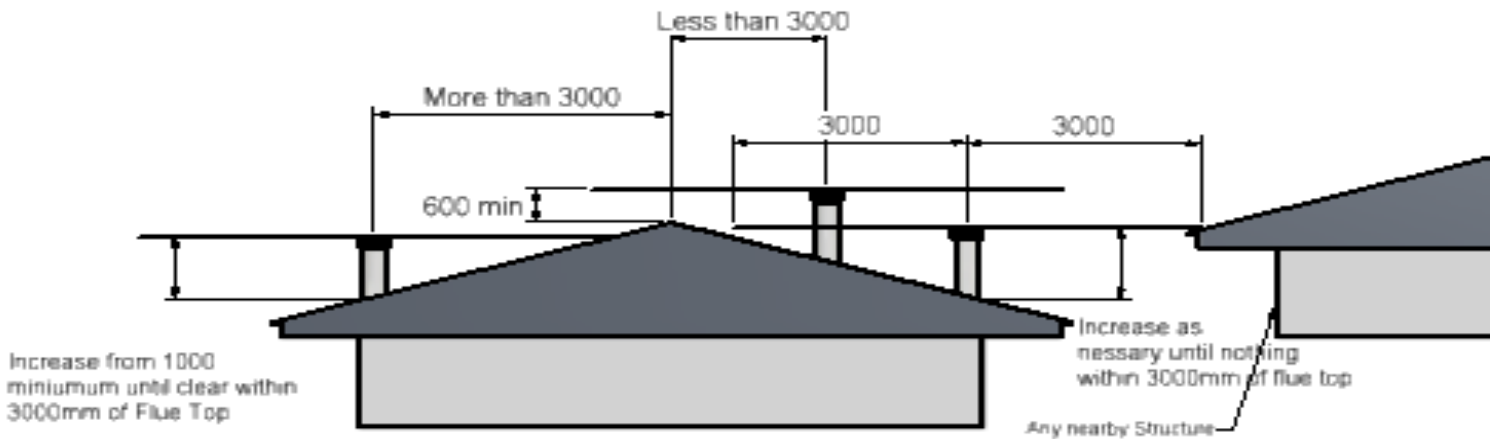

The flue exit is to comply to relevant standards.

3D View

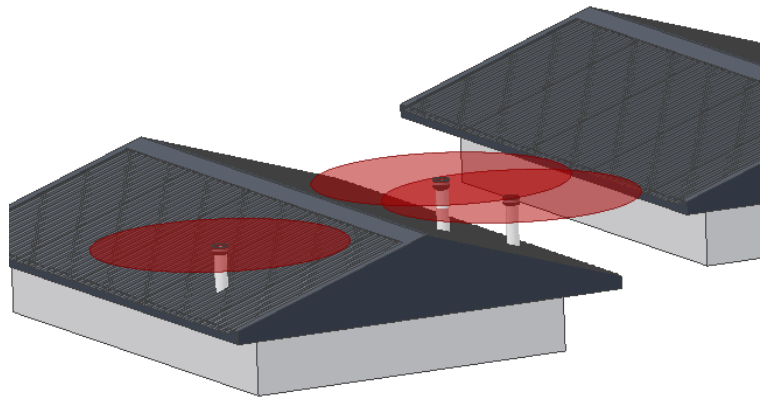

FRAME OUT AND TRIM OUT DETAILS FOR CHIMNEY CHASE

Option X – Singled Lined Flue System

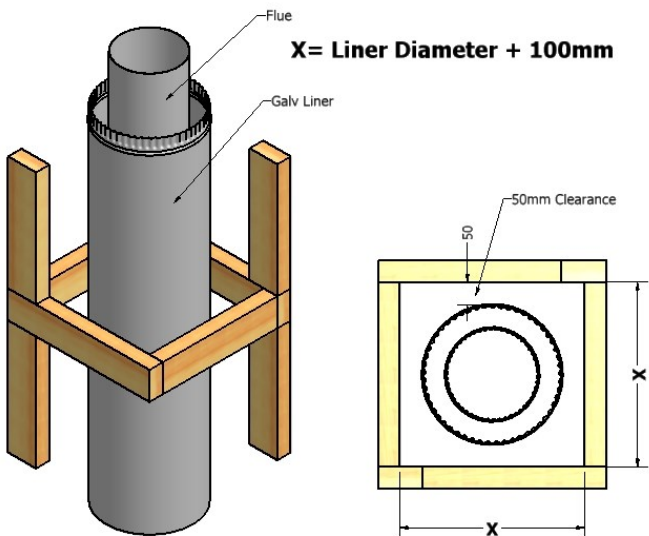

Option Y – Double Lined

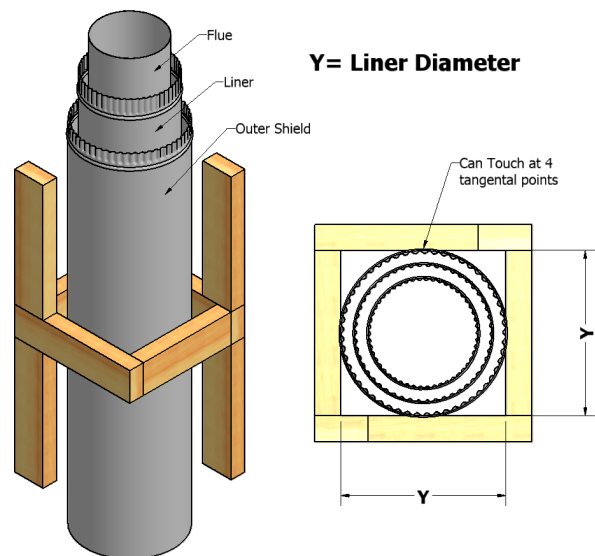

Due to continued product improvement, Warmington Ind LTD reserves the right to change product specifications without prior notification.

COMBUSTABLE MANTEL CLEARANCES

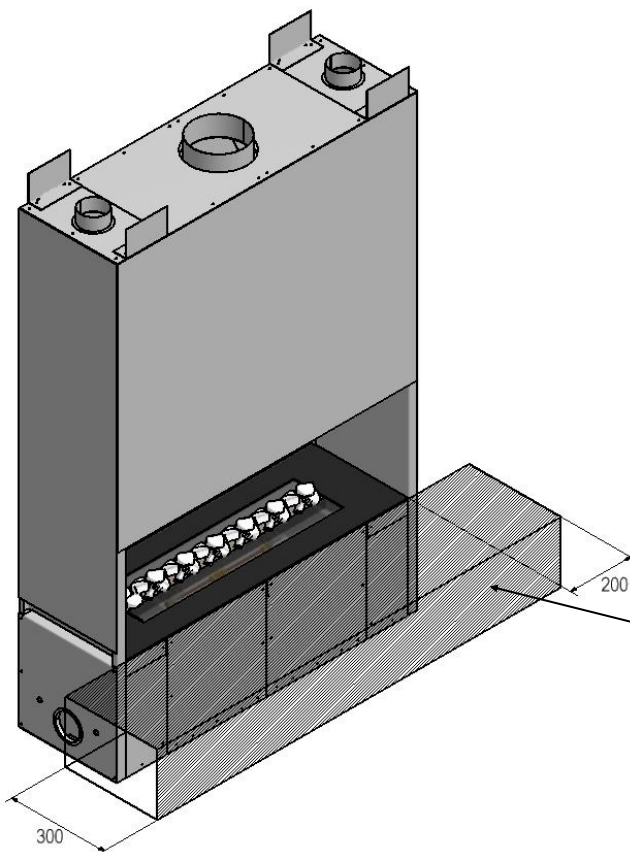
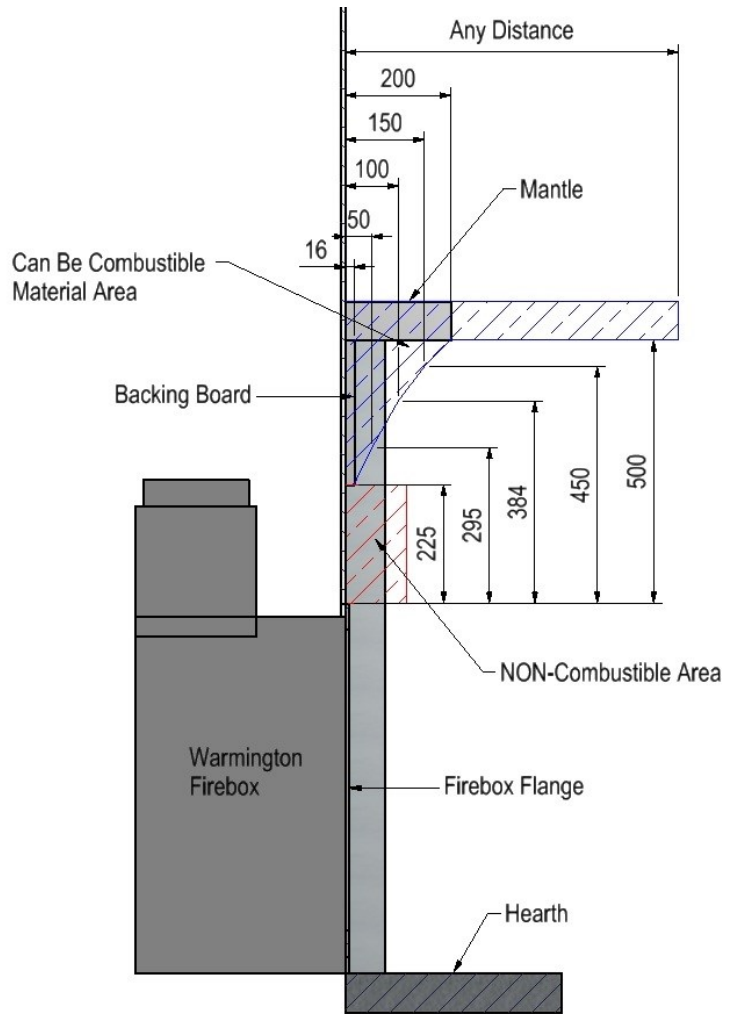
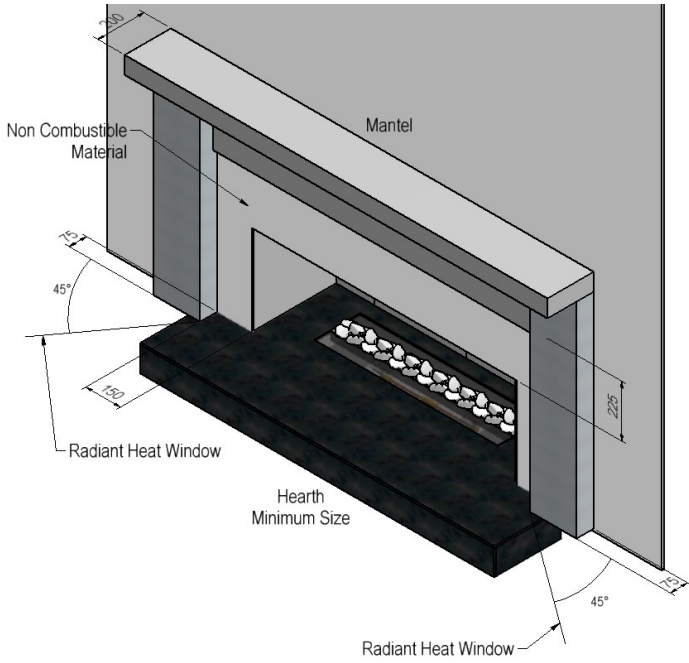

Note:
For Combustible Floors
Minimum Floor Protector of 300mm (A) must be maintained.

NOTE:
Additional Costing for T.V Above Fire-
Consult your nearest Warmington Agent
Visit: www.warmington.co.nz
For Specification

Minimum requirement for floor protector

GENERAL NOTES

NOTES:

- Service annually or more if required.
- Custom built to clients requirements to relevant standards and the appropriate building codes.
- The Appliance and Flue System must be installed in accordance with relevant standards and the appropriate Building codes.

WARNINGS:

- **WARNING; ANY MODIFICATION OF THE APPLIANCE THAT HAS NOT BEEN APPROVED IN WRITING BY THE TESTING AUTHORITY IS CONSIDERED AS BREACH OF NZ STANDARDS.**
- **WARNING; DO NOT USE FLAMMABLE LIQUIDS OR AEROSOLS TO START OR REKINDLE THE FIRE.**
- **WARNING; DO NOT USE FLAMMABLE LIQUIDS OR AEROSOLS IN THE VICINITY OF THIS APPLIANCE WHEN IT IS OPERATING.**
- **WARNING; DO NOT STORE FUEL WITHIN HEATER INSTALLATION CLEARANCES.**
- **WARNING; WHEN OPERATION THIS APPLIANCE AS AN OPEN FIRE USE A SPARK SCREEN.**
- **CAUTION: THIS APPLIANCE SHOULD BE MAINTAINED AND OPERATED AT ALL TIMES IN ACCORDANCE WITH THESE INSTRUCTIONS**

DATA PLATE	
Note : Data is for 2 separate burners	
Model	Custom
Width	
Type of Gas / Pressure	
Pressure At Jet Kpa	
MJ/Hr Per Pan Burner	
Total MJ/Hr	
Nº of Injectors / Size of Jet	
Size of Jet	
Date Manufactured	
Serial Numbers	CUB – 0

Debonair Series of Deceptive Flame Effect Fires

TO THE INSTALLER / GAS FITTER and ELECTRICIAN

NOTES:

- Service annually or more if required.
- Custom built to clients requirements to relevant and current standards.
- The appliance and flue system must be installed in accordance with the relevant and current standards and the appropriate building codes.
- The appliance and flue system must be tested in accordance with the relevant and current standards and the appropriate building codes.

FLUED GAS APPLIANCES All Gas Fires requiring Warmington Flue Systems shall be Installed to the requirements of the current standards and shall be appropriately designed and constructed to permit safe and effective use. This Appliance must be flued to the outside atmosphere. All Warmington Fires must be Installed with a **minimum of 3.6m** of Approved **Warmington Gas Flue and Liners**.

GAS TYPE All Gas Fires shall operate safely on the Gas Type specified on the Appliance and shall comply with the requirements of The Gas Act 1992 .

APPLIANCE SAFETY Any gas fire appliance shall comply with the safety requirements of the current standards listed under “Related documents” in this specification.

ELECTRICAL REQUIREMENTS All Gas Fire Appliances Installed with Mains Supplied Electrical components for associated use with these Appliances, must comply with The Electricity Regulations 1993.

ELECTRONIC CONTROL SYSTEMS Any Gas Fire Appliance Installed with Manual or Programmable Electronic Control System shall be tested and/or approved by a Recognised Person or Authority.

SEISMIC RESTRAINTS All Fires used for Domestic and Commercial Purposes shall be firmly secured (unless defined as portable or mobile) to prevent dislodgement from their point of fixture or Installation during Seismic Activity. Such Restraint must be of a reasonable expectation .

GAS CONNECTION

A Gas Certificate must be obtained for the Installation and Commissioning of this Appliance and Flue System .

Check that the Gas Type Specified on the Data Plate is correct for the available supply (LPG or NG).

A Copper Gas supply capable of supplying the correct MJ/h , should be brought into the rear of the Installation Cavity through the hole provided . A Flare Nut is provided on the Burner for Gas Connection to the Appliance .

COMMISSIONING AND TESTING OF FIREPLACE (To be carried out by Gasfitter)

Read all the instructions before commissioning. Install coals or logs and burner before commission.

Light appliance and check HIGH/LOW settings. Check operation of appliance and adjust to suit.

Adjust control valve setting if required. After a period of running (30min Plus) check the setting of the pilot and adjust if required. See Spec's for details.

Extinguish appliance, remove test equipment and secure test nipple. Check for Gas Leaks.

Note* The Control Valves are factory set and should not require adjustment.

GAS FITTER TO CARRY OUT STANDARD TESTING FOR COMMISSION:

- Spill test taken at top of opening with smoke or smoke match.
- Leak testing appliance and joints.
- Correct operation of the burner and coal and log lay out.
- Test gas pressures high and low, drop test on supply line.
- 5 second light time across burner. Other testing that may be required.
- Ventilation requirements to the standards.
- Hand over to client, tests and comply to relevant standards.

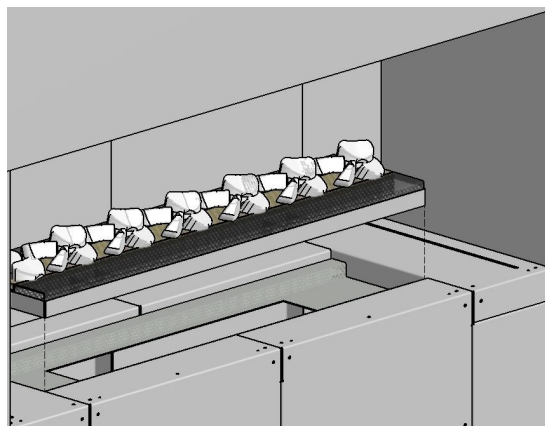

Due to continued product improvement, Warmington Ind LTD reserves the right to change product specifications without prior notification.

VERMICULITE (COURSE) (To be set by Gasfitter)

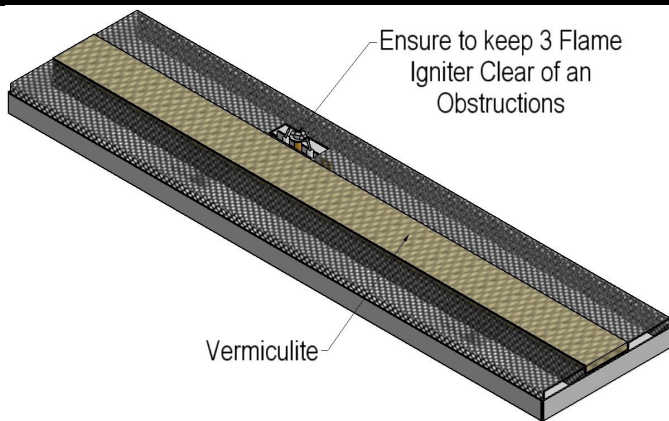

General Coal orientation for optimum effect.

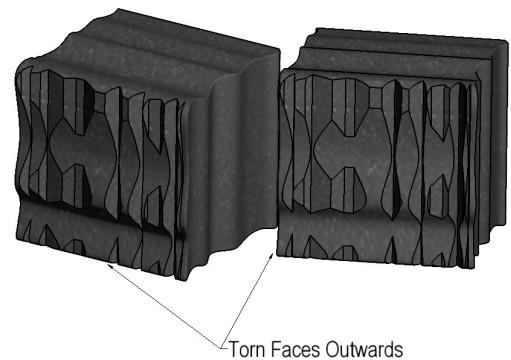

APPLYING THE VERMICULITE : (Coarse—must be larger than the burner plates holes so not to block them)

Apply with care a thin layer of Vermiculite over the Burner, just enough to cover the Burner Tray only.

NOTE: If the burner flame is uneven, the Vermiculite may need to be changed or sifted to remove the smaller pieces that can block the burners holes. The smaller pieces can cause uneven burn and the unit to run dirty.

COALS AND LOGS (To be set by Gasfitter)

Gloves should be worn when handling Ceramic Fibre Coals & Logs : care needs to be taken when handling Coals & Logs , Due to the Carbon on the Coals can stain the surroundings.

HELPFUL HINTS : When Hot use Metal Tongs.

Apply a thin layer of Vermiculite over the Burner , just enough to cover the Burner Tray only as shown above.

Each Coal randomly positioned with the Torn (roughest) Face Outward . **Ensure Coal positioning does not directly block the 3 Flame Pilot .**

The placement of the Coals & Logs may vary to make an even Flame Pattern .

Ceramic Logs and Twigs may be scattered to achieve best Visual Effect .

Fit Burner Grate by sliding R & L Side Metal Pins on Grate, into Holes Located on Burner Side Plates , as shown below .

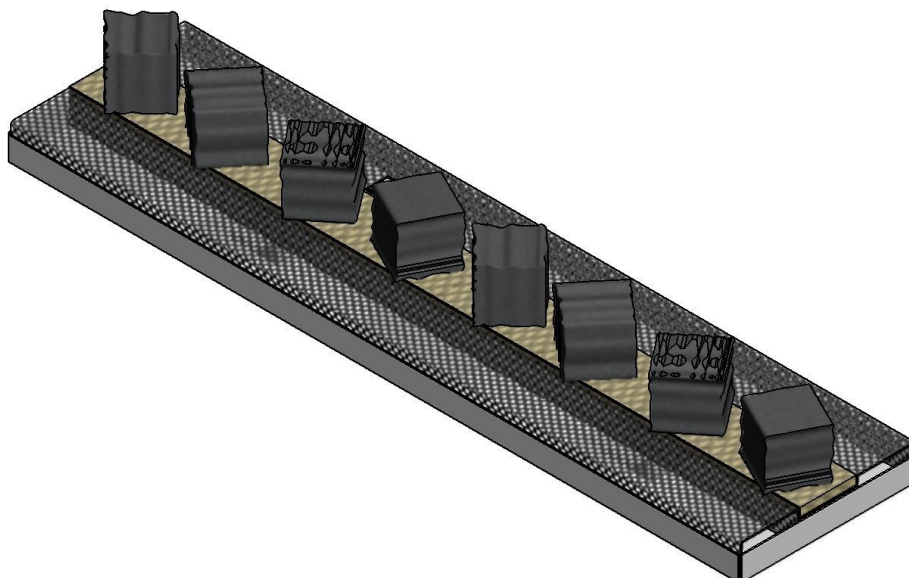

	1200	1600	2000	2400	2800
Number of Coals	8	12	16	20	24

Due to continued product improvement, Warmington Ind LTD reserves the right to change product specifications without prior notification.

VIEW OF GENERAL COMPONENTS

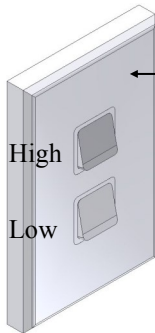

The main isolating switch

Push switch to on and set to High / Low as needed

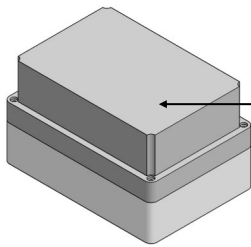

The Main Control box

(Ensure that the box is accessible)

NOTE: Control box must be in a moisture free environment because of electronics

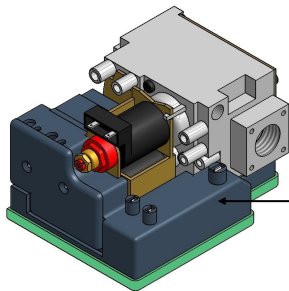

SIT 843 Control Valve

ADJUSTMENT OF THE PILOT—3 FLAME (BOTH SG & EG) (Only to be Adjusted by Gasfitter)

Note: When the Base screw is removed, gas will leak from the out let, ensure that the pilot is not adjusted or the screw is removed when the fire is burning.

- Adjustment of Pilot - 3 Flame : Unscrew Base Screw as shown in Diagram 2 .
- Insert a Screw Driver as shown in Diagram 3 and adjust the Adjustment Screw up inside the 3 Flame Pilot to adjust the Flame Height .
- The Flame must always be passing over the Electrodes &/or File Tube on either side .
- Replace the Base screw and check for leaks.

Note: to Gas Fitters

The 3 flame pilot may need adjustment after a period of running time on set up as the increase in heat in the fire will induce a higher draft in the fire, and may pull in flame away from the File Tube causing the fire to shut down.

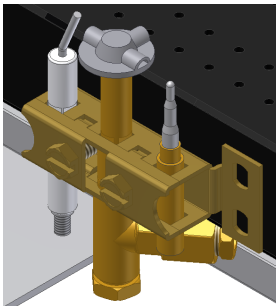

3 Flame Pilot in Assembled State

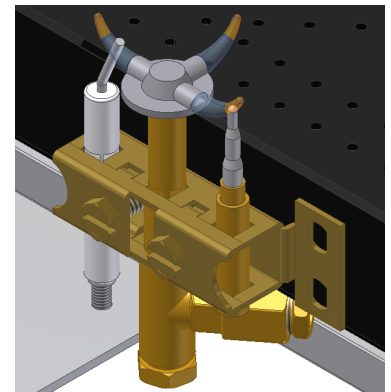
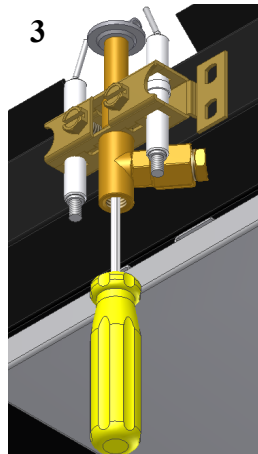
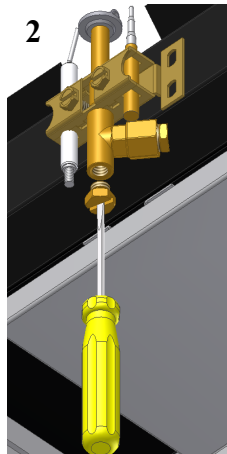

Correct Operation of 3 Flame Pilot

Due to continued product improvement, Warmington Ind LTD reserves the right to change product specifications without prior notification.

TESTING BURNER

Once the unit is installed: (to be tested by the electrician and the gas fitter for correct operation)

Ensure that all gas connections are leak free.

Ensure all components and electrical connections are completed and firmly secured.

Ensure the unit is free of obstruction and any flammable material.

Switch on main power switch (supplied by electrician).

Depress the pulse switch (supplied by electrician).

The high frequency spark electrode will operate. At the same time the gas solenoid valve will open allowing the gas to flow to the burner. If the unit does not light it will automatically shut down.(On flame failure)

The Main power switch should be switched off when burner is not being used to ensure that there is no accidental operation of the unit.

POINTS OF SAFETY—To the Customer /Home-Owner

Your Warmington Gas Decorative Fire operates on the principle of dual radiant and convected heat. Therefore it is important to observe the following precautions associated with any heating appliance or open fire.

- Do not cover or restrict the fireplace upper or lower vents in any way as this may result in a build-up of hazardous gases within the room.
- The fire is not intended for the drying of clothing, bedding etc.
- Avoid installing this appliance in high traffic areas, strong draughts or near drapes or furniture.
- Avoid using aerosols when the appliance is operating.
- Avoid anyone leaning against or lying directly in front of the fire while operating.
- Do not place anything objects into or against the gas fire at any stage.
- The fire may release a small amount of smoke on its first start up which may take 1 or 2 hours to dissipate . This is part of the curing process so ensure there is adequate ventilation within the room.
- Always use a registered Gas Fitter or Electrician for installing and maintenance work
- Always use certified gas cylinders that have been tested and are safe to use.
- Never modify your gas appliance or its settings from those specified by the manufacturer.

APPLIANCE SAFETY Any gas fire appliance shall comply with the safety requirements of the current standards listed under “Related documents” in this specification.

ELECTRONIC CONTROL SYSTEMS Any gas fire appliance fitted with manual or programmable electronic control systems shall be tested and/or approved by a recognised person or authority.

WHAT YOU DO IF YOU SMELL GAS

Open windows and doors

Do not light any gas appliance

Do not use any electrical appliance or switches

Do not use the telephone in your home

Leave the building; shut off the domestic gas supply valve (beside your meter)

Call your gas supplier/gas fitter or the Fire Service for further advice

OPERATION OF YOUR CUSTOM BURNER (WITH ELECTRONIC CONTROL)

Your burner must be installed and tested by a suitably qualified gas fitter or technician prior to use.

TO LIGHT

1. Ensure the unit is free of obstruction and any flammable material.
2. Switch on main power switch (supplied by electrician).
3. Depress the pulse switch (supplied by electrician).

The high frequency spark electrode will operate. At the same time the gas solenoid valve will open allowing the gas to flow to the burner. If the unit does not light it will automatically shut down (On flame failure/ safety feature).

TO SHUT DOWN

Switch the main power switch off to shut down the unit.

**Lighting your gas fire using electronic or remote ignition systems may vary as per manufacturer instructions*

IMPORTANT NOTE ABOUT YOUR DECORATIVE FIRE

Warranty Cover will be considered void if failure to operate the appliance in accordance with the supplied Instructions and Specifications, or is the subject to damage or misuse beyond the expected conditions of normal use which could result in injury or property damage.

FAULT FINDING

1: Pulse Switch depressed and no spark at the electrode:

Check

- Earth Wire connected
- Main power is turned on
- Correct wiring to the wiring diagram (wiring to switches / electrodes)
- The gap between the electrode and pilot is approx 3mm
- The ceramic insulator on the electrode is not cracked
- Electrode Not coated by soot or dust
- Electrode Not burnt out

2: Sparking but failure to light:

Check

Gas supply to the unit is turned on

Solenoid valve operating

Electrically wiring to solenoid

Correct jet for gas supply (LPG / NG)

3: Lights but goes out after a short time:

Check

Flame rod is in the flame path

Setting of the timer in the control box – Contact Dealer

4: Flame burns well away from the burner:

Check

The correct jet for the gas supply (LPG / NG)

Check the gas pressure

Note: If unit is fitted with an LED, the LED will light up on a flame failure.

The cycle from starting to ignition is approx 30 seconds.



12 September 2016

MAINTANANCE

Warmington Industries recommend annual servicing of your gas appliances by an approved Warmington dealer, or gas fitter.

External surfaces should be dusted with a damp, lint-free cloth when the fire is cold.



WARRANTY

Warmington Industries provide 12 months warranty from the date of purchase, for domestic or commercial installations.

This warranty covers:

Replacement parts and labour for gas control components due to manufacturing defects only.

Repair or replacement of the burner components due to manufacturing defects only.

Warranty cover will be considered void if the product is subject to incorrect installation, seal on the control box is broken, failure to operate the appliance in accordance with the supplied instructions and specifications or is subject to damage modification or misuse beyond the expected conditions of normal use.

All installations and servicing must be carried out by and approved Warmington dealer, Gas Fitter or agency.

As part of the manufacturing process, these units have been fully factory tested for correct ignition and fault finding purposes to insure they run correctly before being packaged.

GAS BURNER AND ELECTRICAL CONTROL BOX LAYOUT

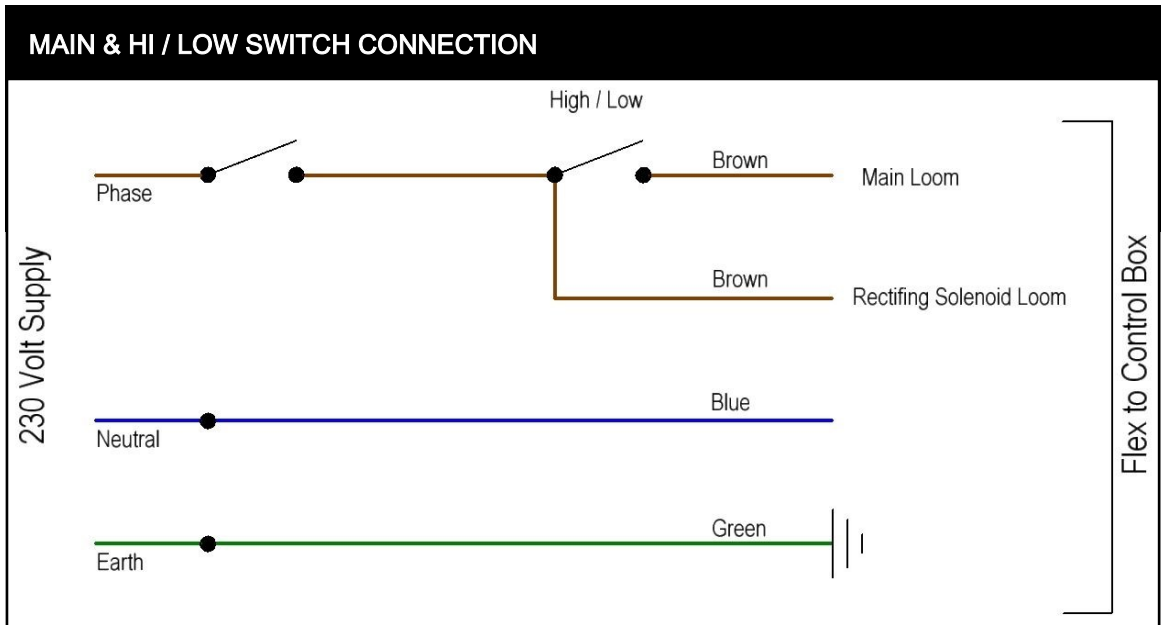
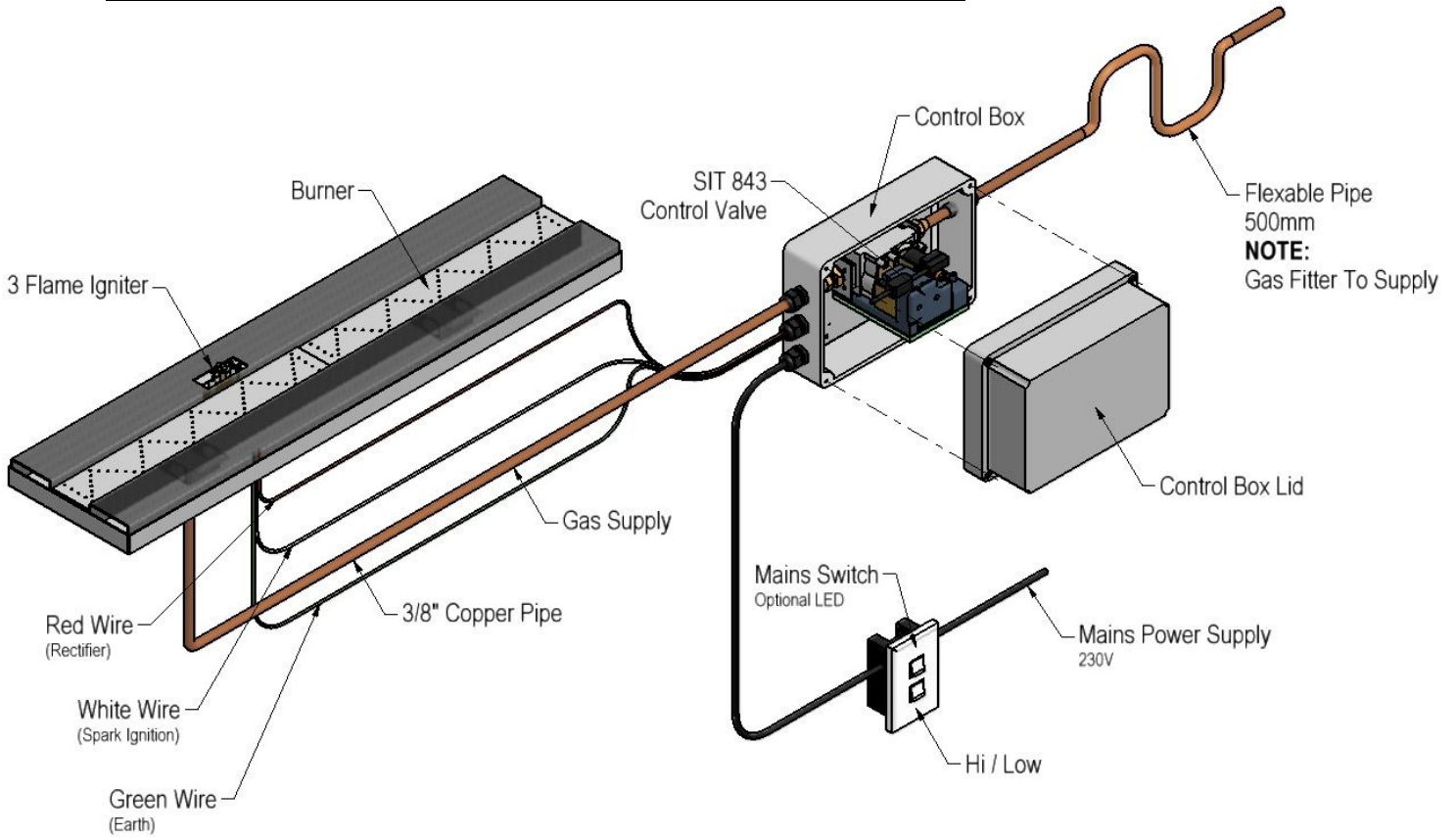

HT Leads
White Lead – Spark
Red Lead - Rectifier

PROCEDURE FOR THE TEST AND COMISSIONING OF YOUR DECORATIVE FIRE.

Ensure Gas Supply and the Power Supply (caution 240V) to the Unit.

- Refer to Data Plate on this Specification for settings. The Data Plate is attached to the under carriage of the Burner .
- Remove Burner Tray ensure the CAT5 cable to the Control Receiver is still connected.
- Loosen the Jet Test point and attach manometer (Digital is preferred). The Test Point is on the Right Hand Side of the Gas Burner , as Shown Below .

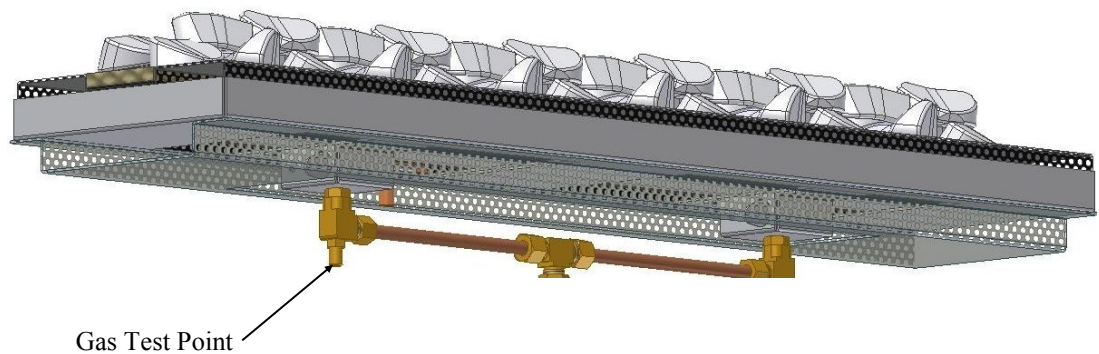

Note: Location of the Test Nipple - may vary from model to model

- Light Appliance, adjust to High Flame setting and check pressure, adjust to Low Flame and check pressure.

NOTE: If setting the Pressure is required it is to be carried out by a Certified Gas Fitter.

- If adjustments are necessary, remove the cap . The Pressure Adjustment Screw and Nut are on the Front Side of the Gas Control Valve (shown in Diagram **B** in this specification) and are **Factory** set.

High Pressure Setting: Set the modulator to Maximum Condition. Screw in **Nut A** to Increase the Outlet Pressure then screw Nut A out to Decrease the Pressure to the desired settings . Use 10mm spanner.

Low Pressure Setting: Turn Off the Power to the Modulator (by disconnecting the Modulator Harness Connection at the Valve - See Wiring Diagram in Page 17 .) and, keep Nut A stationary . Use a screwdriver to screw in **Screw B** to Increase the Pressure and Screw it Out to Decrease the Pressure . Carefully replace the Modulator Plastic Cap .

WARNING: To ensure the Correct Operation of the Modulator it is necessary that the Plastic Cap is returned to its original location .

DIAGRAM B (SHOWING CONTROL VALVE WITH TEST POINTS AND ADJUSTING SCREW).

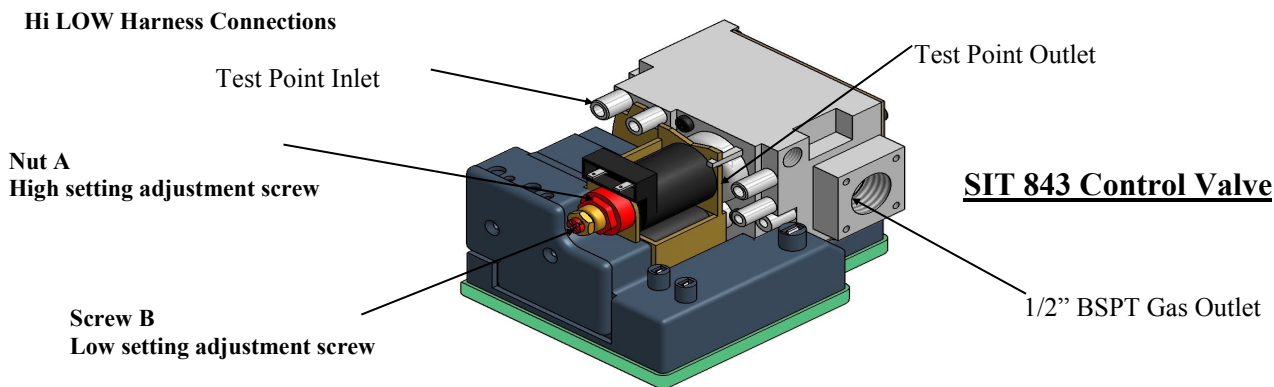

- After checking the pressure, turn the unit off, remove Manometer from the Test Point and Tighten the Test Point Screw. Ensure to check for gas leaks.
- Ensure Power is Off & Reconnect Modulator Harness Connection in the Main Harness. See Diagram B Above .
- Turn the Appliance On and Off a few times to check ignition.
- When you are satisfied that the Appliance is working correctly , fit the Front Panel Assembly back to the Gas Burner.
- NOTE : Ensure you peel the Protective Plastic Coating from any Stainless Steel components if fitted.
- All Burner Aerations are Factory Preset and cannot be adjusted.
- If you are unable to get the unit to operate correctly, refer to troubleshooting before contacting your Local Service Contact as listed.
- It may take approximately 2 hours of operation for the coals/Logs or river rocks to achieve their full flame pattern and glow .
- During the Initial Burning in period, some smoke and smell may be experienced , the appliance should be run on the high position in a well ventilated room until these dissipate .

ADJUSTMENT OF THE PILOT—3 FLAME (Only to be Adjusted by Gasfitter)

Note: When the Base screw is removed, gas will leak from the out let, ensure that the pilot is not adjusted or the screw is removed when the fire is burning.

Note: to Gas Fitters
 The 3 flame pilot may need adjustment after a period of running time on set up as the increase in heat in the fire will induce a higher draft in the fire, and may pull in flame away from the File Tube causing the fire to shut down.

- Adjustment of Pilot - 3 Flame : Unscrew Base Screw as shown in Diagram 2 .
- Insert a Screw Driver as shown in Diagram 3 and adjust the Adjustment Screw up inside the 3 Flame Pilot to adjust the Flame Height .
- The Flame must always be passing over the Electrodes &/or File Tube on either side .
- Replace the Base screw and check for leaks.

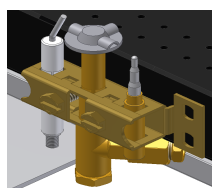

3 Flame Pilot in

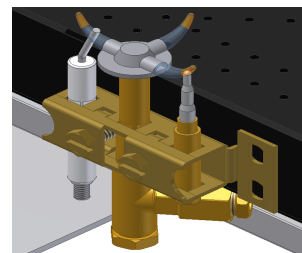
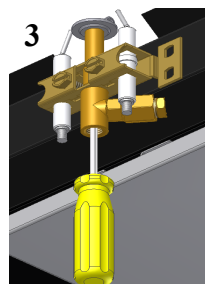
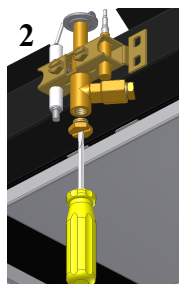

Correct Operation

Due to continued product improvement, Warmington Ind LTD reserves the right to change product specifications without prior notification.

Installing Burner & Control Box Location

Step 1.

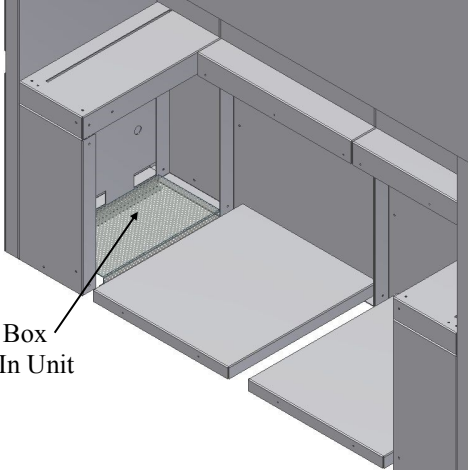

Place Control Box Support Tray In Unit As Shown

Step 2.

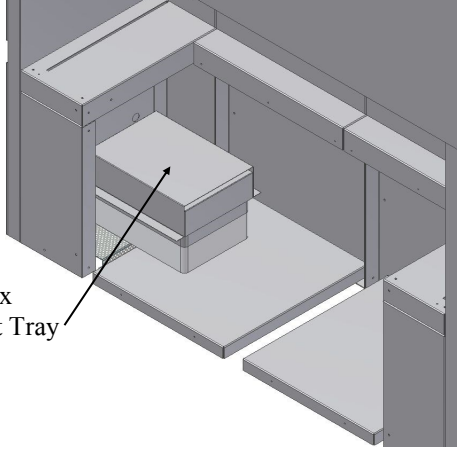

Place Control Box on top of Support Tray

Step 3.

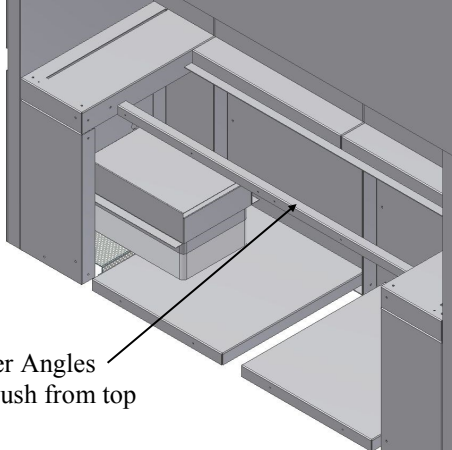

Fit Burner Angles 28mm Flush from top

Step 4.

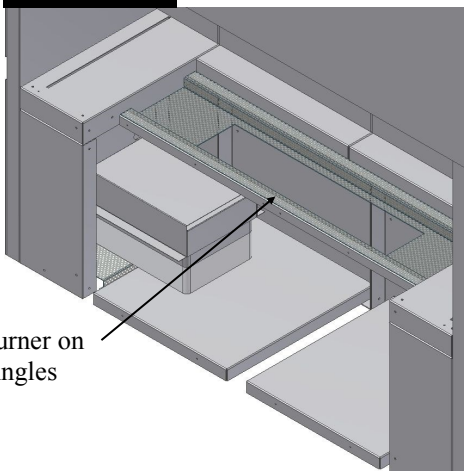

Place Burner on top of Angles

Step 5.

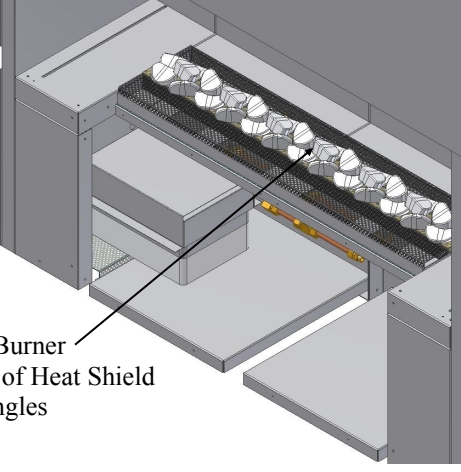

Place Burner on top of Heat Shield and Angles

Access to Gas Test Point

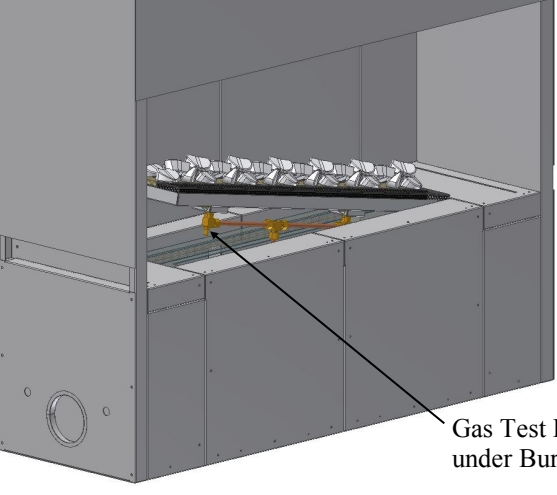

Gas Test Point under Burner

Due to continued product improvement, Warmington Ind LTD reserves the right to change product specifications without prior notification.

GAS STARTER SCHEMATIC DIAGRAM

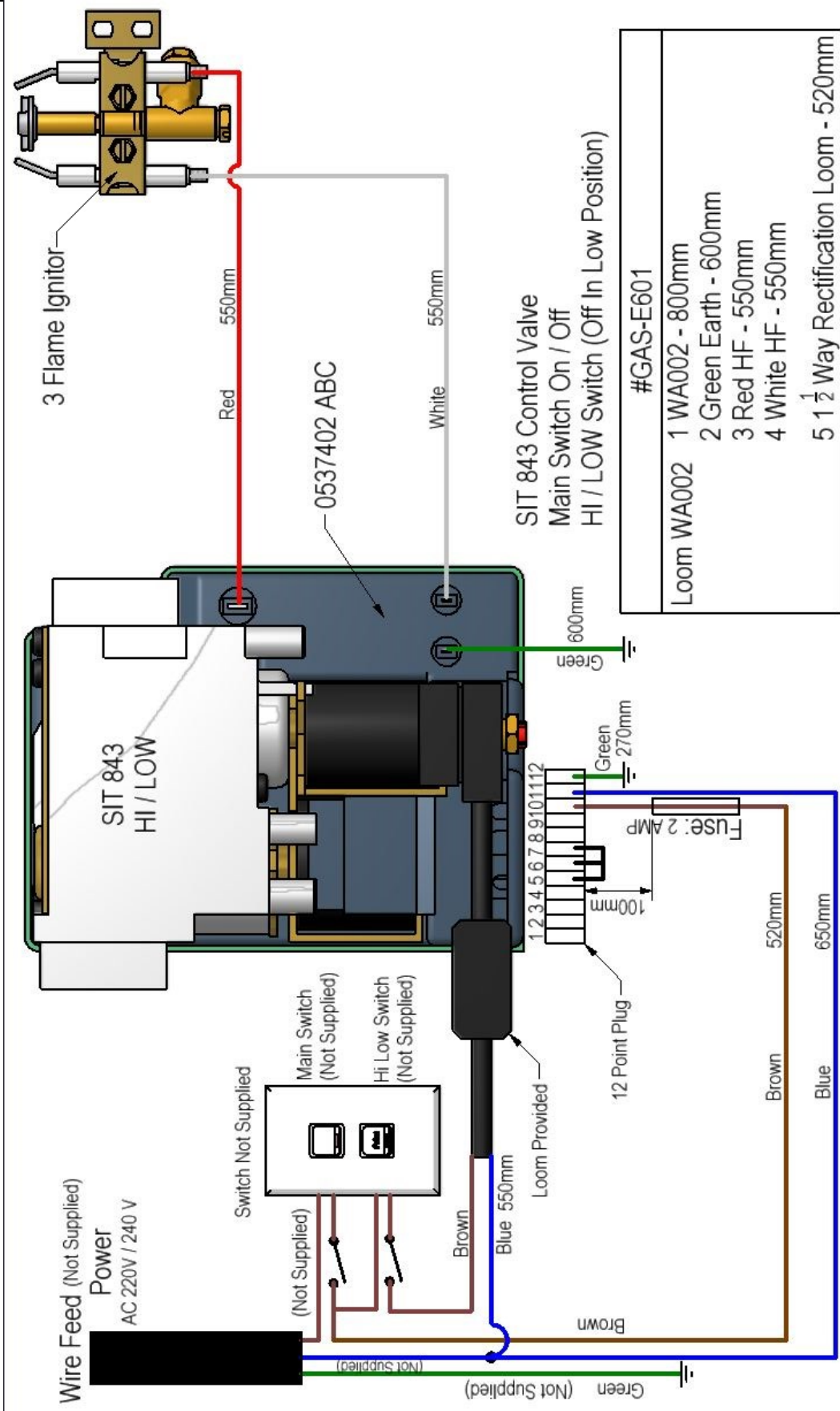

Due to continued product improvement, Warmington Ind LTD reserves the right to change product specifications without prior notification.

GENERAL NOTES**NOTES:**

- These installation and operating instructions should be kept in a safe place. Should you require another copy, download from the **Warmington** website www.warmington.co.nz
- Warranty—for full details on product warranties, contact your local Authorised Warmington Retailer.
- Correct installation, operation and maintenance of this appliance must be maintained to comply with **Warmington** Warranty.
- The appliance and flue system must be installed in accordance with relevant standards and the appropriate building codes.
- This appliance must be serviced annually and any service operation must be carried out by a qualified service person.

WARNINGS:

- **WARNING: ANY MODIFICATION OF THE APPLIANCE THAT HAS NOT BEEN APPROVED IN WRITING BY THE TESTING AUTHORITY IS CONSIDERED A BREACH OF NZ STANDARDS.**
- **WARNING: DO NOT USE OR STORE FLAMMABLE LIQUIDS OR AEROSOLS IN THE VICINITY OF THIS APPLIANCE WHILST IN OPERATION.**
- **WARNING: DO NOT PLACE FLAMMABLE MATERIALS ON OR AGAINST THIS APPLIANCE.**
- **CAUTION: THIS APPLIANCE SHOULD BE MAINTAINED AND OPERATED AT ALL TIMES IN ACCORDANCE WITH THESE INSTRUCTIONS.**
- **CAUTION: ALL SERVICING MUST BE CARRIED OUT BY AN AUTHORISED SERVICE TECHNICIAN.**
- **CAUTION: MAKE SURE THE USE OF CORRECT FUEL TYPE WITH THIS APPLIANCE.**

NOTE: Keep a copy of these instructions for operating and maintenance guidelines.



Industries 1994 LTD
PO Box 58652, Botany 2163, Auckland
www.warmington.co.nz