

# SI 1250 - 1500 Single Flue

## Open Fire - Wood Burner Installation Instructions

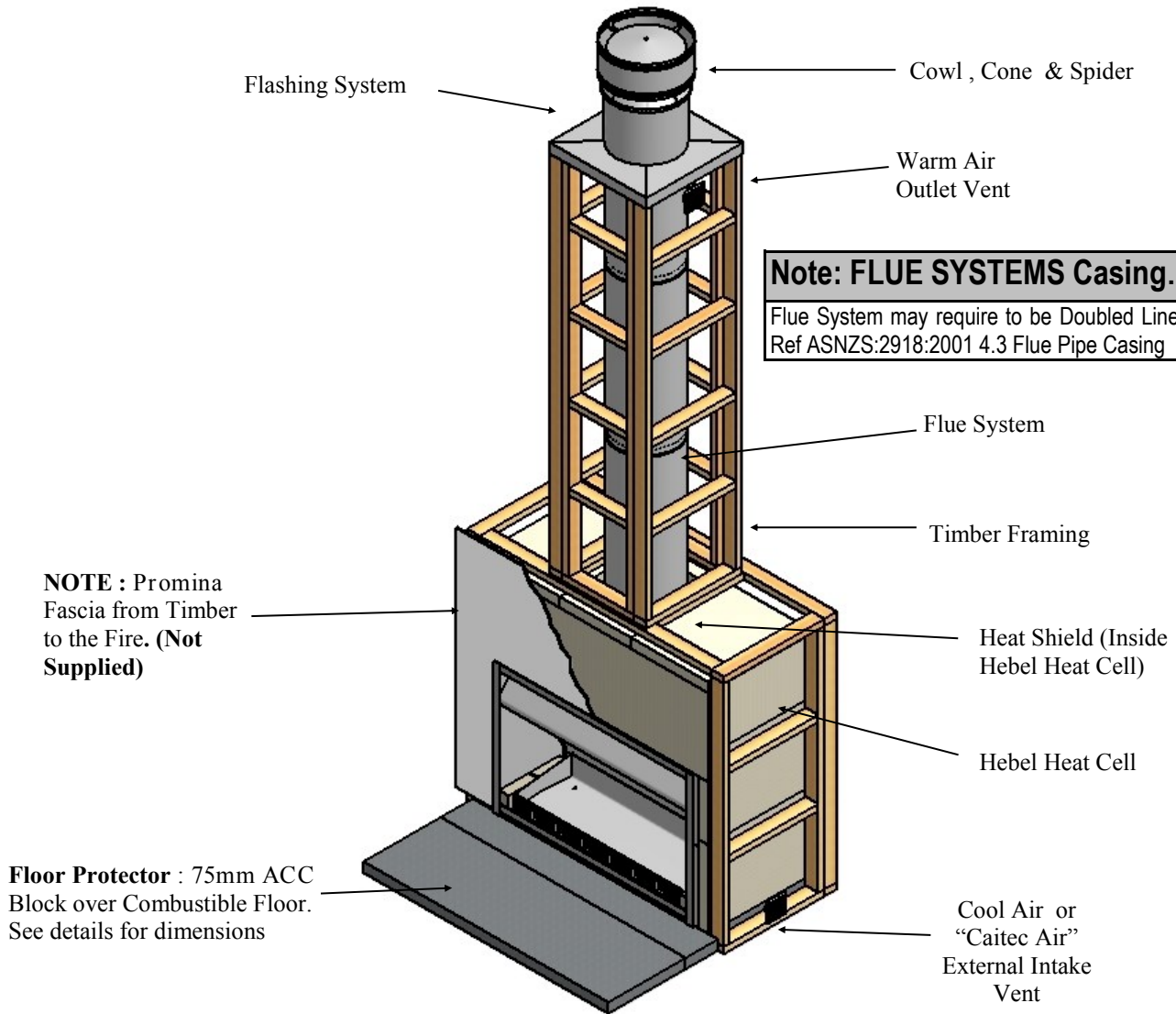

**Visit [www.warmington.co.nz](http://www.warmington.co.nz) for Spec's, DWG's and PDF uploads of Fires**

### Fire, Flue System and Instructions to Comply with ASNZS 2918:2001

Keep these Instructions for further reference.....Ensure that you have the correct and current Installation details for the Warmington Fire

#### Installation

The Warmington unit is to be Installed by a Certified Warmington Installer or a Certified NZHHA SFAIT Installation Technician .  
See [www.homeheat.co.nz/members](http://www.homeheat.co.nz/members) for a Certified NZHHA SFAIT Installer in your area .

#### IMPORTANT

Read all the Instructions carefully before commencing the Installation. Failure to follow these Instructions may result in a Fire Hazard and void the warranty

## POINTS TO CONSIDER PRIOR TO INSTALLATION

Location of the Fire. Open fires are better located at one end of a room or area, as they project the heat away from their opening.

### The Topography of the land .

The slope and position of the land in relation to the home has a bearing on how the wind will interact with the fire and flue system. Care needs to be taken to ensure that the flue termination is in the correct position to maximise performance.

### The Prevailing Wind.

Care needs to be taken to ensure that the flue termination is in the correct position as wind and gusts that hits the flue and cowl system may overcome the cowl and draft back down the flue into the home. This can be a combination of down draft and high pressure.

### Hearth and Plinth:

The Height of the Hearth off the Floor. The Finishing that is to be used on the Hearth is to be allowed for at the design stage.  
Note : Ensure Air Intake at Base of Firebox is not blocked or restricted .

### Positioning of the Flue System:

There is a maximum distance that an offset flue can be Installed . Reference to AS/NZS 2918:2001 .

### Flue And Fire Clearance:

To be maintained to the Manufactures Instructions &/or Comply with appropriate Standards & Building Codes .

### Pressure Differential, Venting & External Air into the Building :

All fires need air to burn and draw correctly, Kitchen Fans, Air Conditioning units, High Wind Zones, Naturally forming Draft spaces, can all have an effect on the pressure difference from inside the building to the outside. A lower pressure in the building may induce a draft down the flue system and back into the building causing the fire to smoke or spill into the building. **Care needs to be taken at the design and installation stage to adequately vent the building, or some mechanical system to ensure that there is always a neutral or positive pressure at the fireplace and a negative pressure at the flue outlet.** This will ensure that the draft in the flue system is always to the outside.

“CAITEC AIR” the limits and requirements. See details in these Spec’s

### Wind Noise:

You may encounter wind noise in some installations. It is recommended to use an enclosed chase with a chimney pot to help reduce noise. There will always be some noise from the flue systems of all fireplaces.

## INSTALLATION ORDER OF OPERATIONS—General

### Prior to Construction and Installation Important Notes:

Install to AS/NZS 2918:2001.

Install to manufacture’s specifications.

All new installations require a permit.

For special requirements concerning materials (timber mantle and surrounds) within close proximity of Warmington products, please contact your local Warmington Technical Consultant.

### Stage 1: Frame Construction Procedure by Builder.

Mark out flue centre.

Mark out heat cell clearance requirements.

Construct plinth only, to required height. \*

### Stage 2: Install Procedure by Certified “Warmington Installer” only or see [www.homeheat.co.nz](http://www.homeheat.co.nz) go to “members” & follow Instructions to get a Certified NZHHA SFAIT Installer .

Fit fire to plinth.

Fit adaptor to Firebox.

Fit Heat Cell system

Fit flue system.

Fit cowl and flashing system

### Stage 3: Finishing Procedure by Builder.

Construct hearth to required thickness. \*

\* Note: certified installer can install hearth and plinth.

**Ensure that the Warmington and flue system is swept annually or more frequently if required.**

### To sweep flue and firebox:

Cover front of fire with sheets.

Remove cowl from top of chimney.

Sweep from the top, down the flue.

Remove all soot and ash.

Ensure cowl and bird protection is clean and replaced.

Visually inspect fireplace and flue system.

**WARMINGTON FIREBOX DIMENSION**

Firebox		SI 1250 SF	SI 1500 SF
Firebox Width	A	1250	1500
Firebox Height	B	1000	1000
Firebox Depth	C	600	600
Flange Width	D	1300	1550
Flange Height	E	1025	1025
Adaptor Height	F	402	570
Centre of Flue	J	403	403
Flue	K	350	350
Flue Liner	L	450	450
<b>Heat Output</b>	kW		
Peak*		30	35
Range*		14	14

\*Estimated unless stated otherwise.

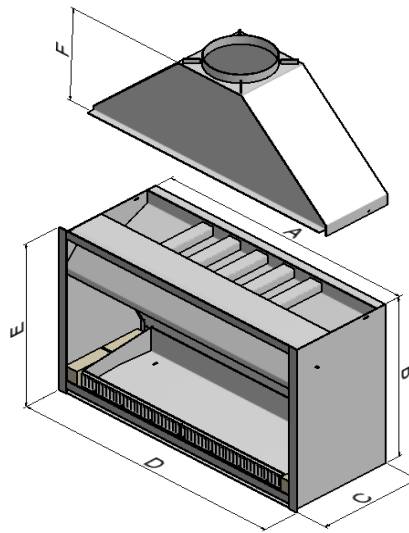

Minimum Flue Height	
Flue Height	3600
Measured From Top of Adaptor	B + F + 3600

**FIREBOX HEAT SHIELD CABINET**

Firebox		SI 1250 SF	SI 1500 SF
Cabinet Width	G	1345	1595
Cabinet Height	H	1455	1620
Cabinet Depth	I	571	571

**Note:**  
DO NOT FRAME OUT TO THESE DIMENSIONS .....  
CHECK HEAT CELL AL-  
COVE ON PAGE 5 & 6.

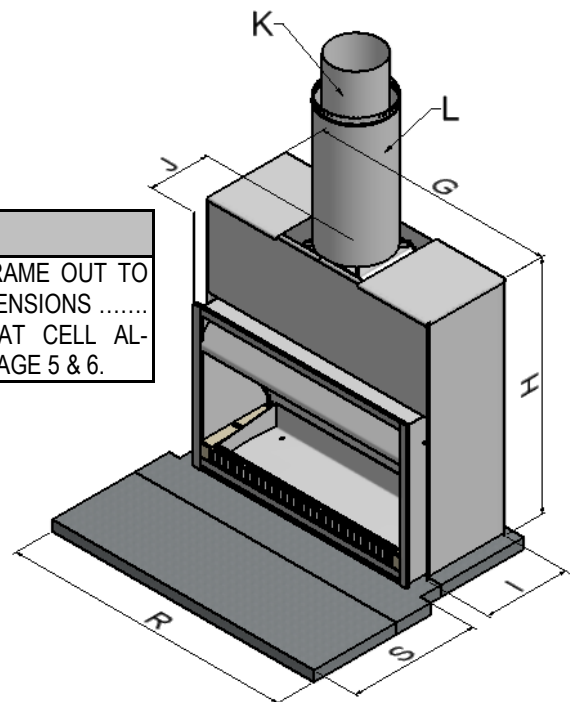

**FIREBOX ACC BLOCK HEAT CELL**

Firebox		SI 1250 SF	SI 1500 SF
Surround Width	GG	1500	1750
Surround Height	HH	1535	1700
Surround Depth	II	750	750

**Adaptor Fitting**

Seal Adaptor to Firebox using High-Temp Gasket Sealant. Bolt through holes provided .

**Seismic Restraint**

Secure Firebox through anchor positions provided.

**Check List**

Firebox	
Adaptor (Fastenings)	
Ash pan	
Bricks	
Louvers	
Badge	
Damper Handle	
Packed By	

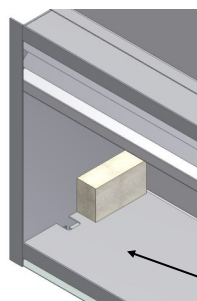

Seismic Restraint Located under bricks

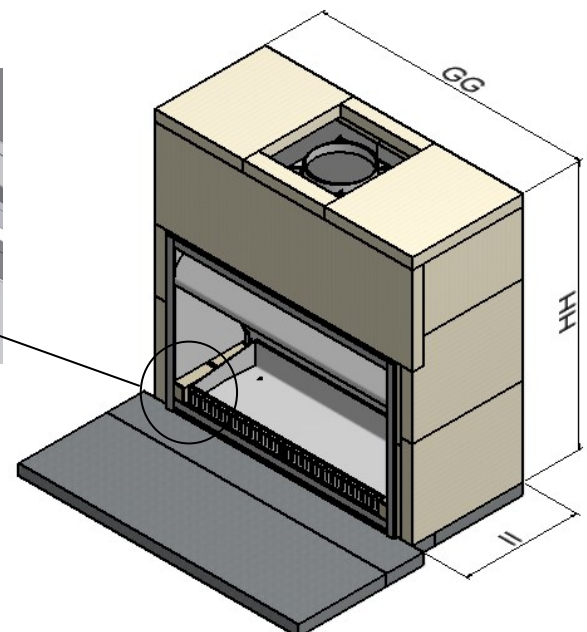

## FIREBOX INSTALLATION

This is a general installation guide only – Contact a “NZHHA Installer” for Installation Advice.

See : [www.homeheat.co.nz](http://www.homeheat.co.nz) , choose “members” & pick your Area & Fire type (wood / Gas etc) this will provide you with a NZHHA Certified Installer (use the SFAIT Installers Only .)

1. All the dimensions are minimums
2. Fit the Plinth into position in the Cavity. If onto a wooden floor ensure that an insulating plinth is fitted as per the specifications. **Ensure that the plinth is elevated to allow for finishing on the hearth. (See Hearth and plinth details)**
3. Assemble back panel and sides of the heat shield, position into Cavity.
4. Fit the firebox into the Cavity, allow for the Fascia to fit behind the flange and to the timber framing. (Approx 10mm) Bolt the fire box to the plinth or through to the floor with the bolting point provided on the Left and Right hand sides of the fire box (seismic restraints).
5. Fit the Adaptor to the Fire box. Ensure that exhaust sealant is used between the fire and Adaptor. Bolt into position with the bolt in the Left and right hand sides of the Fire box.
6. Install the flue system.
7. Fit the front of the heat shield and rivet into position. Fit Lintel cap and Caps to the heat shield.
8. Fit the Fascia kit between the heat shield and behind the firebox flange. This fitment will be firm and will complete the shielding around the fire system.

## HEARTH & PLINTH CONSTRUCTION DETAILS

### IMPORTANT NOTE :

#### **Note: Hearth and Plinth Construction.**

For Combustible Flooring an Insulating Hearth and Plinth of 75mm ACC Block is required.

Plinth to be Offset above Hearth by the Hearth Finishing's ( e.g. Tiles / Granite / Solid Plaster / etc )

Raised Hearths & Plinth's with cantilevered Hearths must be adequately supported to take the weight in Accordance with the NZ Building Code .

This is a Raised & cantilevered Hearth. See page 15 for further Raised Hearth Detail

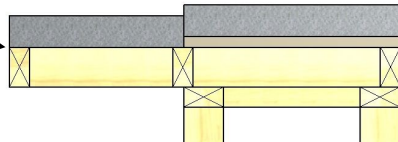

Offset for  
Hearth  
Finishing

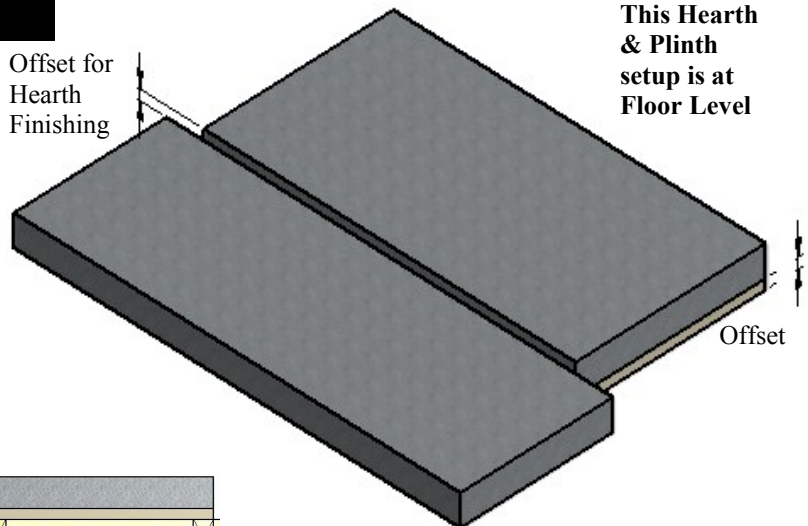

**This Hearth  
& Plinth  
setup is at  
Floor Level**

**\*Note: If Solid Plastering the Heat Cell Structure, it is recommended to use a Fibreglass mesh with a Latex Based Plaster to minimise the chance of the Solid Plaster cracking. (See your Solid Plasterer for correct materials and applications).**

Visit the Warmington Web Site for “ACC Block (Hebel)” instruction (PDF Download)..

## “CAITEC” TECHNOLOGY—ROOM AIR REPLACEMENT

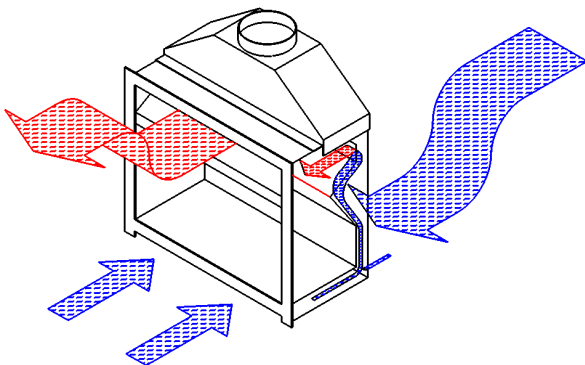

**Caitec**” draws air from an external air source to ensure that the open fire has pre-heated combustion air maximising efficiency while maintaining the home at constant pressure equilibrium, reducing the risk of back drafting .

Ensure that the cavity is vented to Outside fresh Air and the Warmington will take care of the rest. 2 x 100mm Diameter vent are required (Or equivalent to that.)

**Builder to supply external air to the Cavity and the “Warmington Fire” takes care of the rest.**

**NOTE: Point to Consider regarding Pressure Differential.**



**TIMBER FRAMING & TRIM OUT DETAILS**

Firebox		SI 1250 SF	SI 1500 SF
Heat cell Clearance Width	O	1550	1800
Heat Cell Clearance Depth	P	780	780
Heat Cell Clearance Height	Q	1560	1750
Hearth Width	R	1800	1900
Hearth Projection	S	750	850
Window Height	V	1560	1750
Window Width	W	1550	1800
Chimney Chase Clearance	X	550	550

**MINIMUM HEAT CELL ALCOVE CLEARANCES & FRAME OUT**

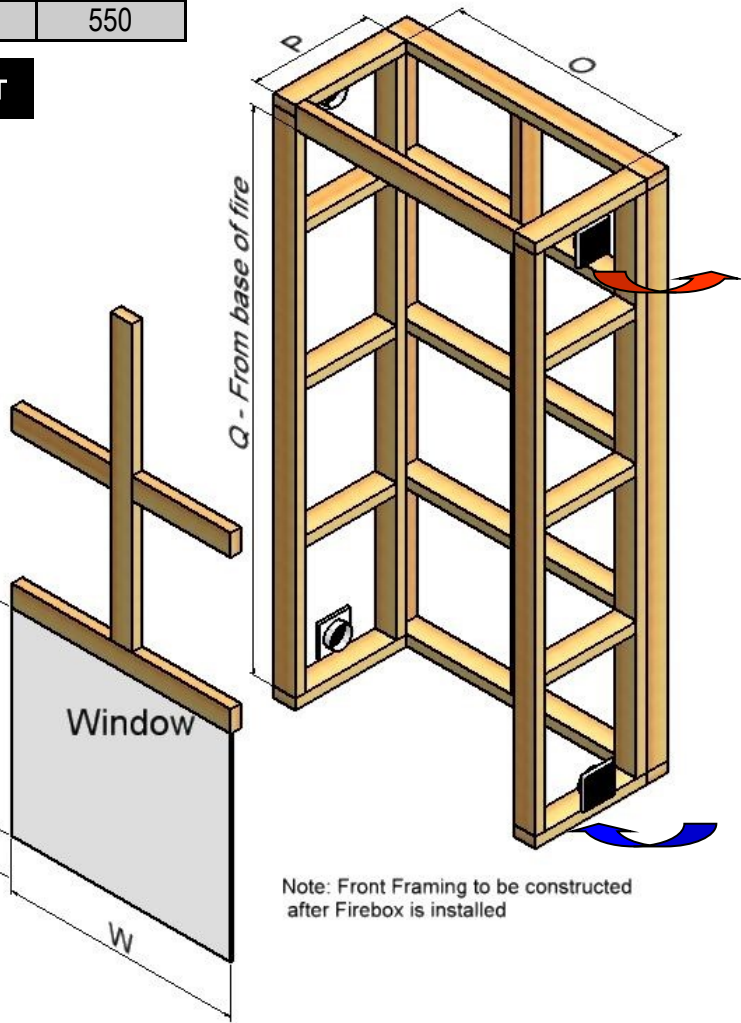
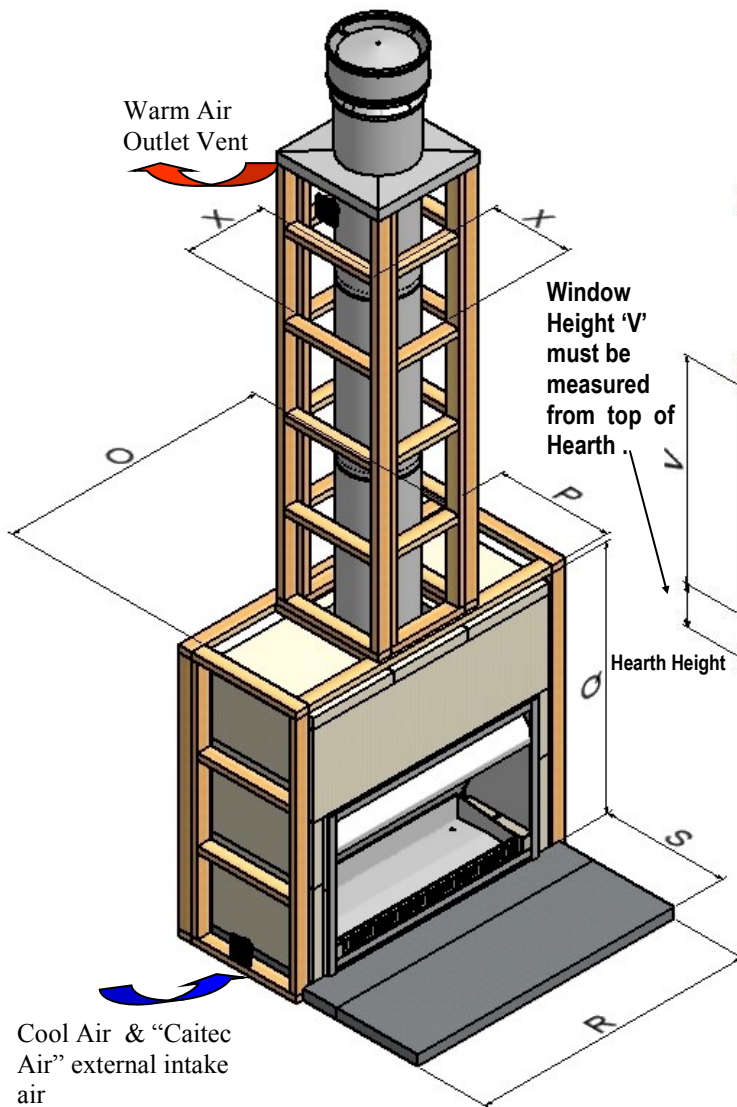

**Note:**  
Centre Line of Flue is 'NOT' in Centre of Alcove

**Note:**  
All Framing Dimensions are Internal Only

**TIMBER : PLAN, FRONT ELEVATION & CROSS SECTION**

Firebox		SI 1250 SF	SI 1500 SF
Hearth Width	R	1800	1900
Hearth Projection	S	750	850
Plinth Width	T	1500	1750
Plinth Depth	U	750	750
Centre of Flue	J	403	403
Chimney Chase Clearance	X	550	550

**Note:**  
Centre Line of Flue is 'NOT' in Centre of Alcove

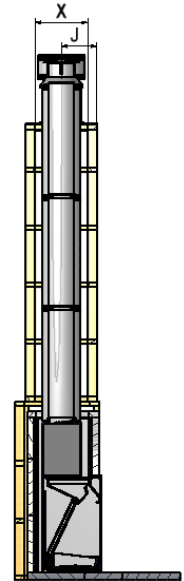
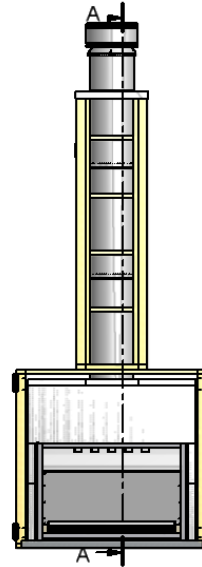
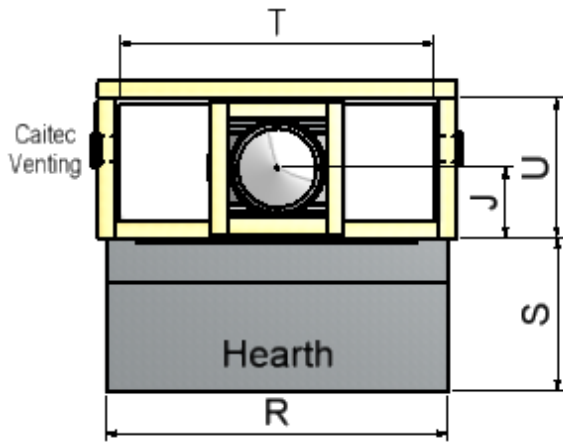

**BLOCK : PLAN, FRONT ELEVATION & CROSS SECTION**

Firebox		SI 1250 SF	SI 1500 SF
Hearth Width	RR	1990	1990
Hearth Projection	SS	750	850
Plinth Width	TT	1610	1610
Plinth Depth	UU	700	700
Centre of Flue	JJ	403	403

**Note:**  
Centre Line of Flue is 'NOT' in Centre of Alcove

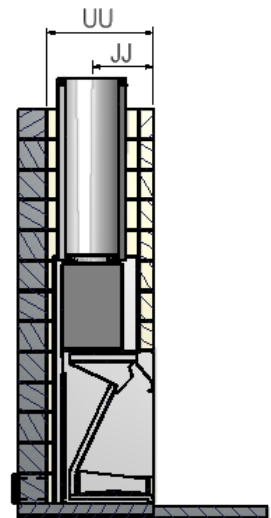
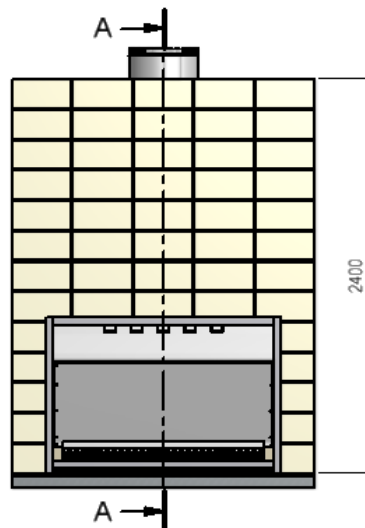
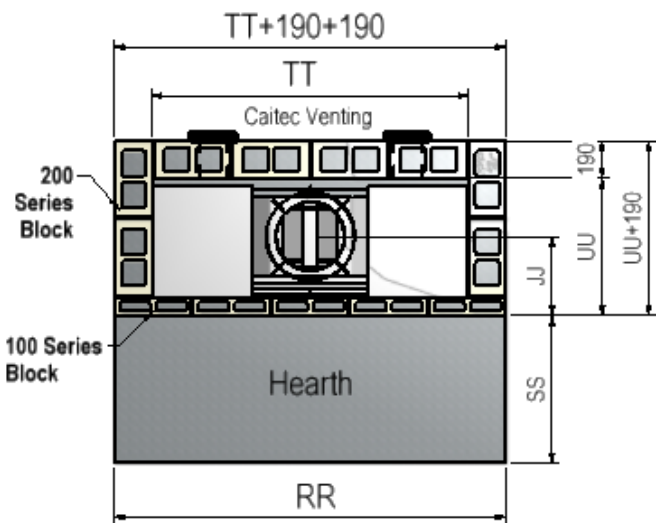

**BLOCK ALCOVE & TRIM OUT DETAILS**

Firebox		SI 1250 SF	SI 1500 SF
Heat cell Clearance Width	OO	1610	1610
Heat Cell Clearance Depth	PP	700	700
Heat Cell Clearance Height	QQ	2390	2390
Hearth Width	RR	1990	1990
Hearth Projection	SS	750	850
Window Height	VV	1010	1010
Window Width	WW	1280	1530
Chimney Chase Clearance	XX	550	550

**Note:**  
Centre Line of Flue is 'NOT' in Centre of Alcove

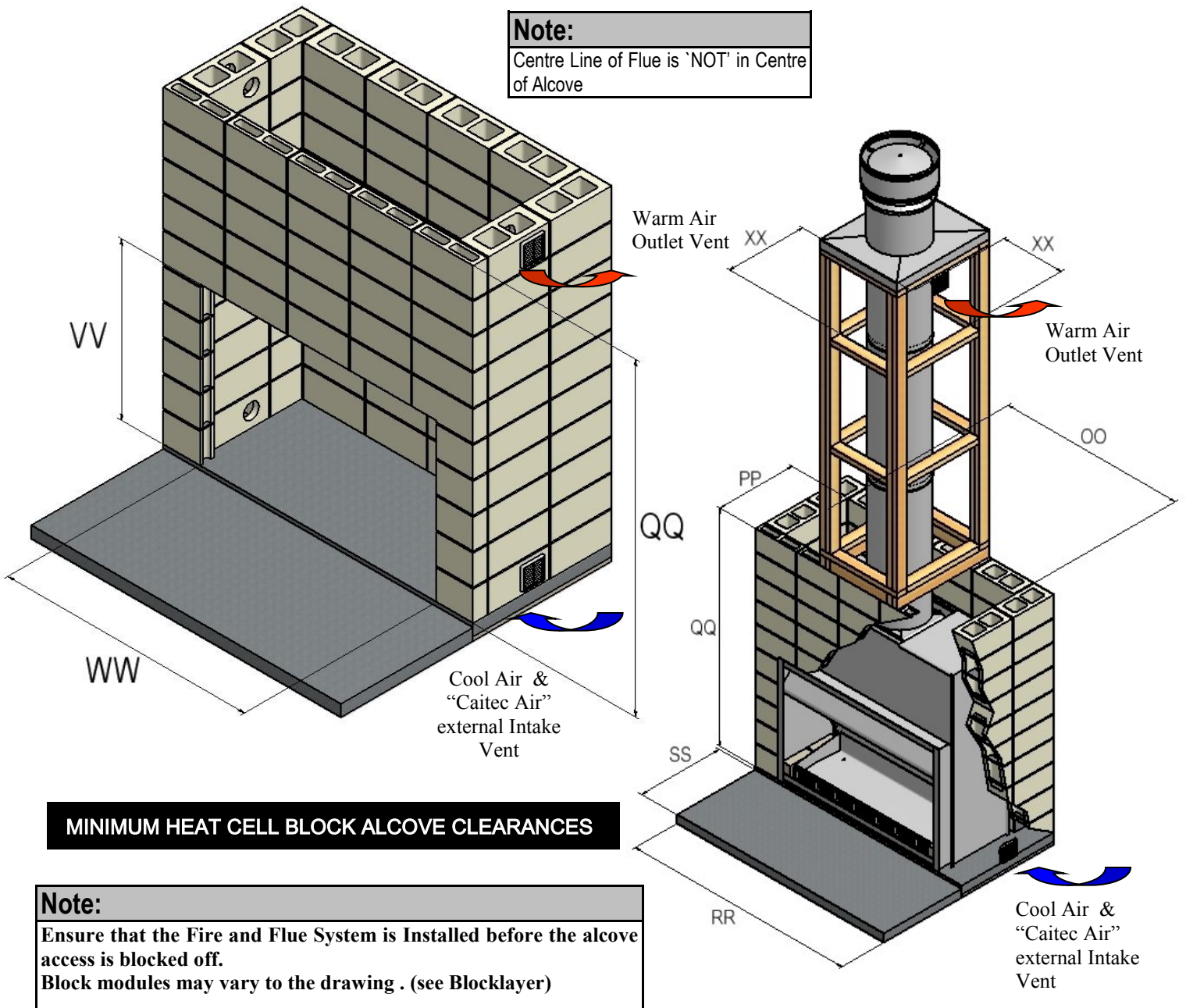

**MINIMUM HEAT CELL BLOCK ALCOVE CLEARANCES**

**Note:**  
Ensure that the Fire and Flue System is Installed before the alcove access is blocked off.  
Block modules may vary to the drawing . (see Blocklayer)

**HEAT SHIELD ASSEMBLY - FOR INSTALLATION INTO HEBEL HEAT CELL (NO FASCIA KIT)**

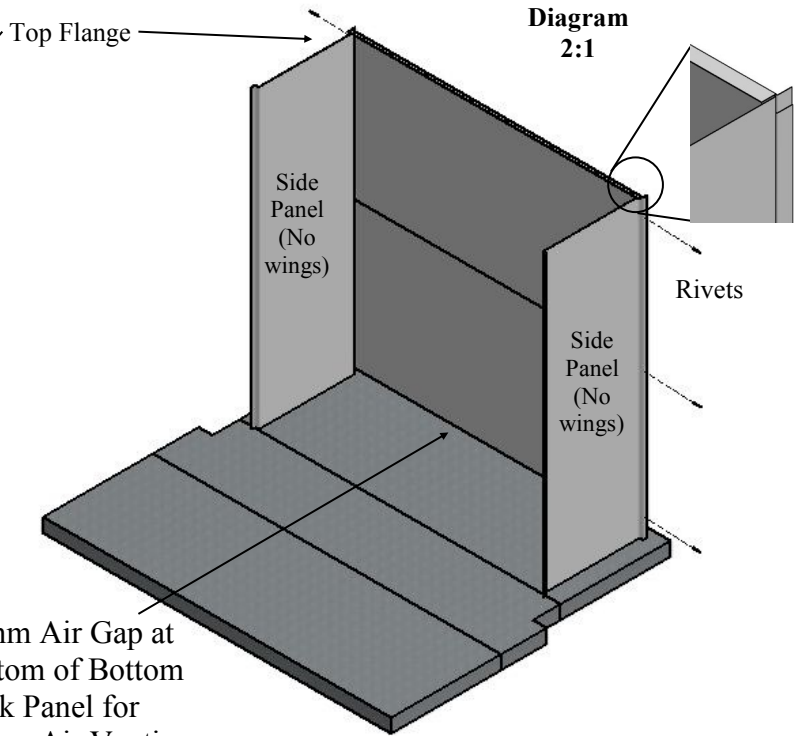
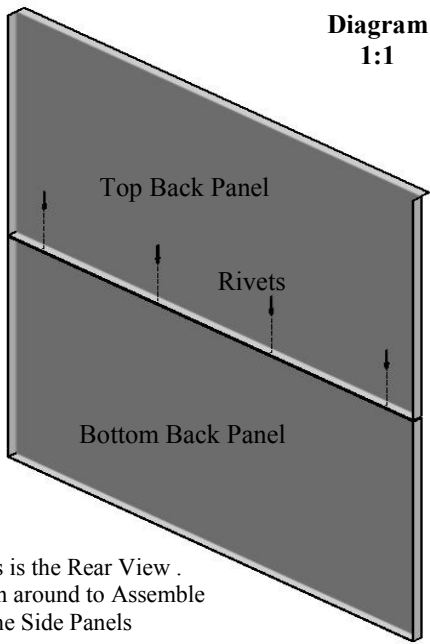

This is the Rear View .  
Turn around to Assemble to the Side Panels

**Step 1 :**  
Assemble Top & Bottom Back Panel together by Riveting together at the centre as shown in diagram 1:1 .  
The Top Back Panel has a double Shield layer at the Top .

**Step 2 :**  
Rivet 2X Side Panels to pre assembled Back Panels as shown in 2:1 , ensure the Top Flange on the Back Panel sits on the Side Panels creating a 20mm Air Gap at the bottom for the Caitec Air Venting .

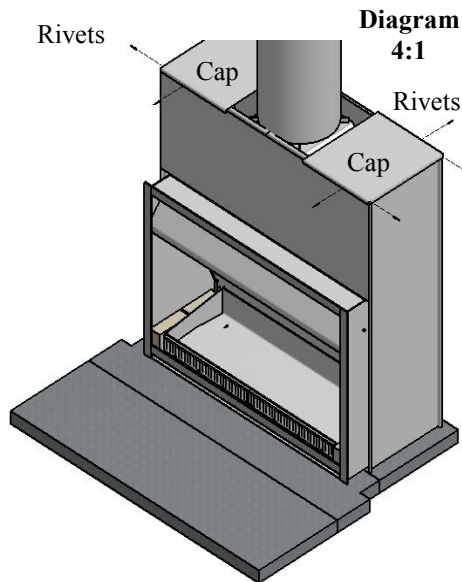
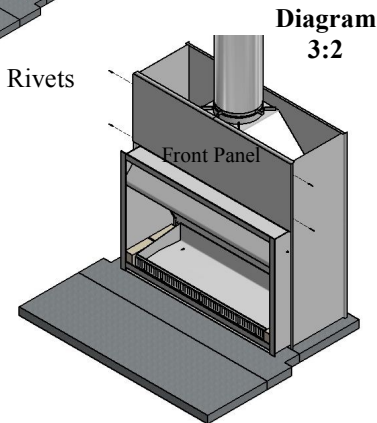
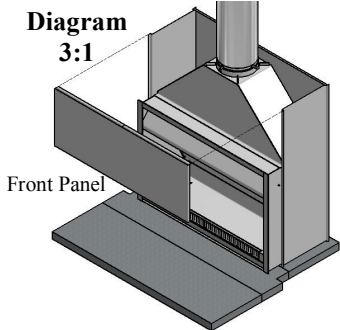

Heat Shield Check List	
Front Panel	
Back Panel	
Side panel LH	
Side panel RH	
Top Cap LH	
Top Cap RH	
Packed By	

**Step 3 :**  
Install Firebox/Adaptor & secure in place , then Install first length of Flue with a Spacer at the Bottom , assemble Front Panel to Heatshield as shown in diagram 3:1 & secure in place by riveting as shown in 3:2

**Step 4 :**  
Assemble Top Caps to Heatshield & secure in place with rivets as shown in diagram 4:1



**HEBEL HEAT CELL & CUT SIZES FROM PANELS for SI 1250 SF**

The Hebel Heat cell is constructed around the firebox, using 75mm Hebel (see attached minimum spec below).

(2400x600x75) Power Panels are required for basic heat cell construction as shown in detail "Firebox with Hebel Surround".

\*Note: If plastering the Heat Cell structure, it is recommended to use a fibreglass mesh with a latex plaster to minimise the chance of the plaster cracking. (See your plasterer for correct materials and applications).

**Note: HEBEL KITSET ASSEMBLY Details....**  
When purchasing the "Hebel Heat Cell Kit" the assembly Guide will come with the Kit.

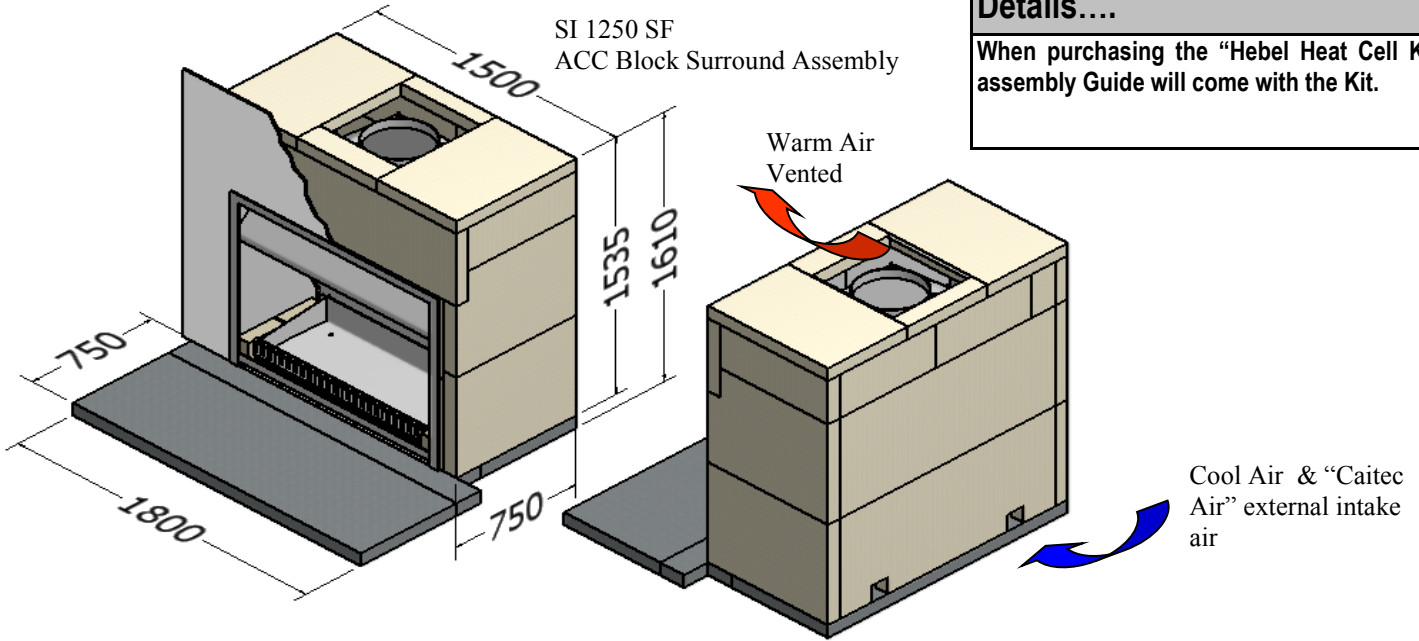

**HEBEL HEAT CELL & CUT SIZES FROM PANELS for SI 1500 SF**

**Note: HEBEL KITSET ASSEMBLY Details....**  
When purchasing the "Hebel Heat Cell Kit" the assembly Guide will come with the Kit.

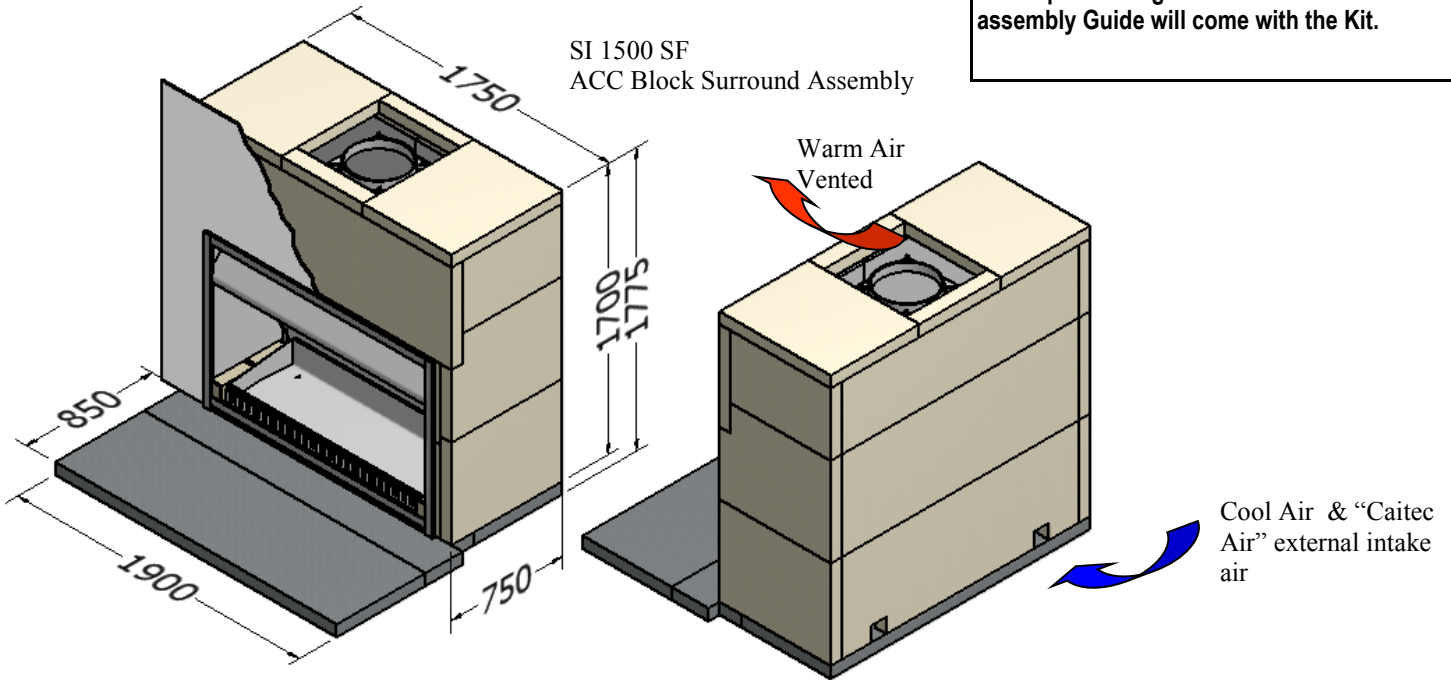

## FLUE DETAILS DIMENSIONS

Minimum Flue Height	
Flue Height	3600
Measured From Top of Adaptor	B + F + 3600

**Note: FLUE SYSTEMS Casing....**  
 Flue system may require to be Doubled lined to comply.  
 Ref ASNZS:2918:2001 4.3 Flue pipe casing

Flue details	No:	SI 1250 SF	SI 1500 SF
Cowl	1	350	350
Cone	1	350	350
Top Spider	1	350	350
Flue Diameter	3	350	350
Liner Diameter	3	450	450
Spacer	3	350/450	350/450

**NOTE:** Ensure that a Standard Tested Warmington Flue system is used on the Warmington fires.

## FLUE SYSTEM INSTALLATION GUIDE

This is a general installation guide only – Contact a “NZHHA Installer” for Installation Advice.  
 See : [www.homeheat.co.nz](http://www.homeheat.co.nz) , choose “members” & pick your Area & Fire type ( wood / Gas etc) this will provide you with a NZHHA Certified Installer (use the SFAIT Installers Only .)

1. Install the first length of flue pipe with the crimped end down, inside the Adaptor collar, ensure that the flue pipe is sealed into the collar with exhaust sealant. Rivet the flue in 3 places around the Adaptor collar. Place a spacer around the flue pipe approximately 150mm above the adaptor collar. Secure in position by tightening the screw and nut.
  2. Install the second length of flue pipe with the crimped end down and fit by riveting in at least 3 places around the flue pipe joint. Ensure that the flue is sealed into position with sealant.
  3. Install the first section of flue pipe liner with the Crimped end up, over the flue pipe and over the spacer that is fixed to the flue pipe. This spacer will keep the liner concentric about the flue pipe.
  4. Position flue spacer at the flue pipe joint for every length of “Flue pipe” and “Liner”.
- Repeat the Steps from 1 – 4 to the installed required height of the flue system. The flue system is to comply with ASNZS 2918:2001 4.9.1

- a “the flue pipe shall extend not less than 4.6m above the top of the floor protector.”
- b “ the minimum height of the flue system within 3 m distance from the highest point of the roof shall be 600mm above that point.”
- c “the minimum height of the flue system further than 3 m from the highest point of the roof shall be 1000mm above the roof penetration.”
- d “no part of any building lies in or above a circular area described by a horizontal radius of 3 m about the flue system exit.”

1. **NOTE:** The last length of flue pipe needs to extend past the liner so that when the “top spider” and the “Flashing cone” are fitted, that the “flashing cone” and the “flue pipe” are **flush**, or that the “flue pipe” is **5mm lower** than the “Flashing cone”.
2. Fit the “Top Spider” into position, ensure that the legs of the spider are fitted inside the liner and that the spider is positioned hard down onto the liner and tighten with the screw and nut.
3. Place the “Flashing cone” over the “flue pipe” and press hard down onto the “Top Spider”. (Note that the “Flue pipe” and the “Flashing Cone” are either flush or the “Flue pipe” is 5mm Lower than the “Flashing cone”.) Ensure that the “Flashing cone” is clear for the venting from the “Liner” and the “flue pipe”.
4. Fit the “Cowl” to the top of the flue pipe. The “Cowl”, “Flashing cone”, and the “Flue pipe” can be secured to each other with the uses of a stainless steel self tapping screw. This will allow the “Cowl” to be removed for cleaning.
5. Flue system may require Bird Proofing due to the installation and locations, discuss this with your installer for the best advice.
6. If the Flue system is installed into a “Chimney Chase”, allow for air vent as close to the top of the chase as practical, or allow venting through the “Chimney Chase Flashing”. A “Venting Flashing cone” and a 25mm gap around the Liner with a “Venting Flashing Cone-Spider” can be used. Ref : to Figures .....

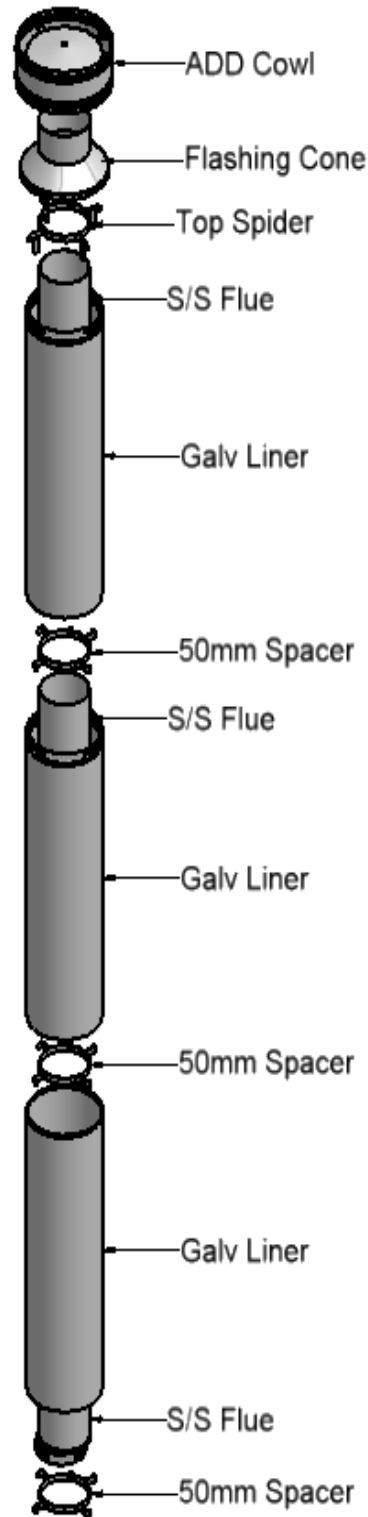

**FLUE PENETRATION Vented through Alcove (Single lined Flue System)**

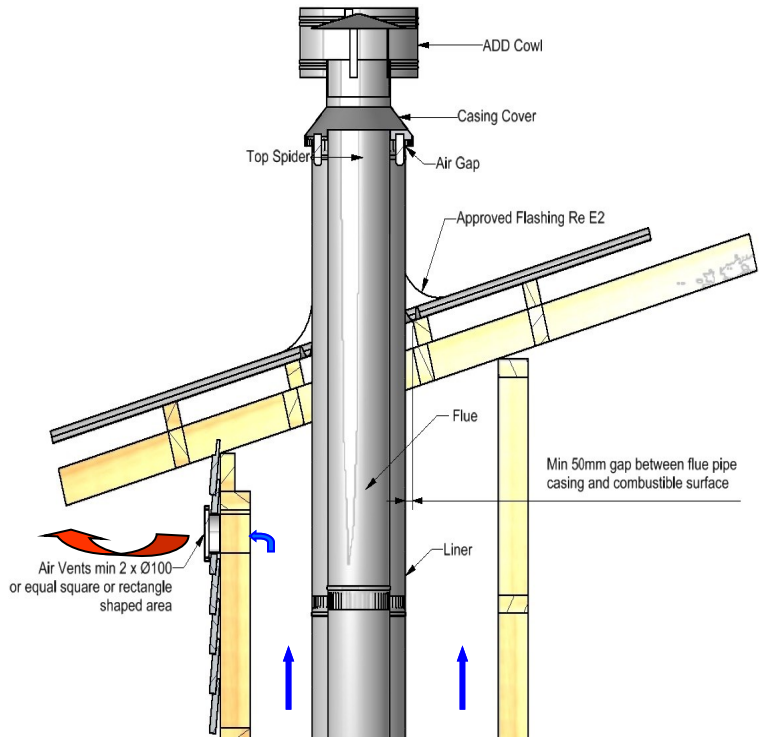

**FLUE PENETRATION Vented through Alcove (Double lined Flue System)**

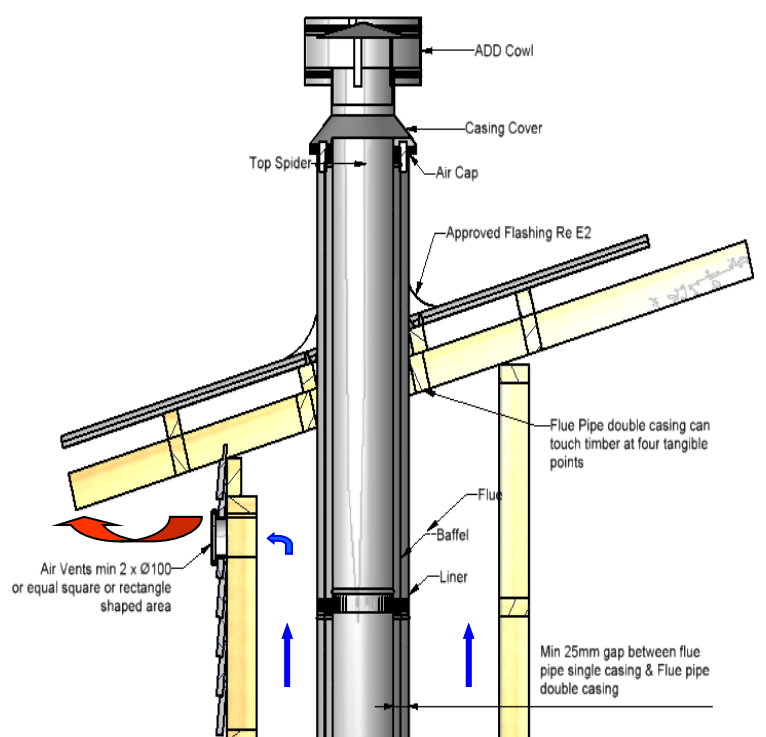

**FLUE PENETRATION Vented through Top Flashing**

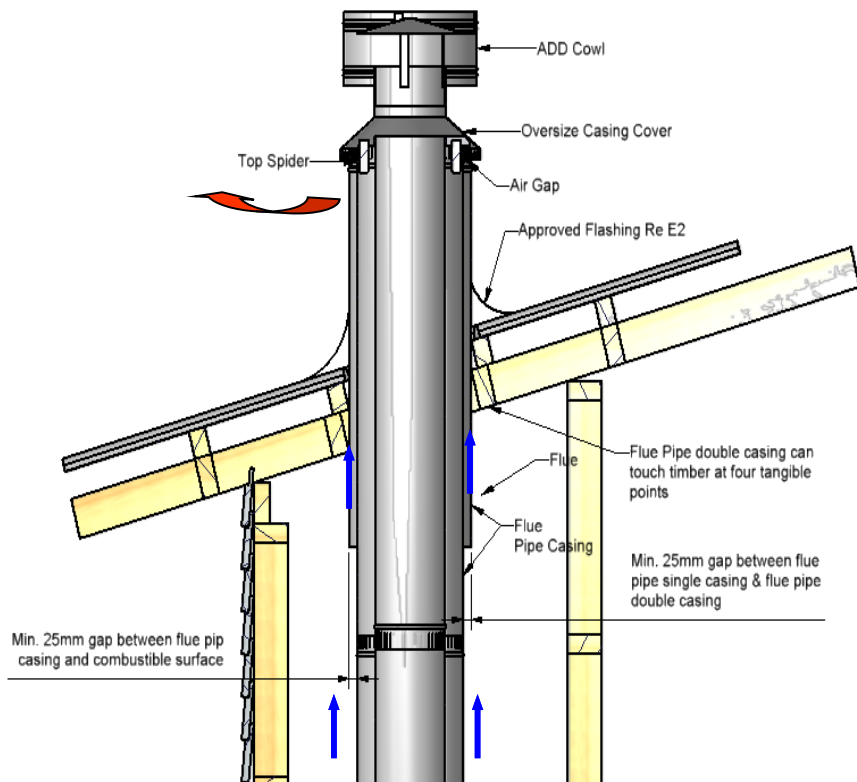

**Note: FLUE SYSTEMS Casing....**  
 Flue System may require to be Doubled Lined to comply.  
 Ref AS/NZS:2918:2001 4.3 Flue pipe casing

**Note :**

External Requirements  
 Refer to AS/NZS2918:2001 4.9.1

Install Flue system to AS/NZS2918:2001

When using a rubber or Bitumen flashing (Butynol, Dectite) an Additional Flue pipe Baffle is required.

All external air vents & ceiling penetrations must be bird proofed with permanently fixed screens.

All flashing to comply with E2.

All external air vents and ceiling penetrations are to be Vermin and Rodent proof.

Test Report Number	Date of Report
04/1039	20 <sup>th</sup> July 2004
04/1040	20 <sup>th</sup> July 2004
04/1041	20 <sup>th</sup> July 2004

**CHIMNEY CHASE FLASHING DETAILS**

**SETTING ADD COWL AND FLASHING CONE HEIGHT**

**General Chimney Chase Flashing Lay Out**

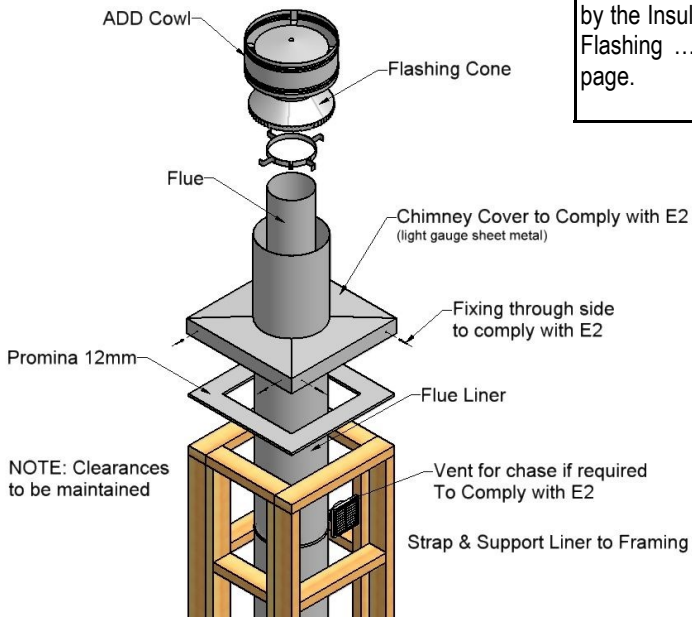

**Note:**  
Flashing Spigot height is determined by the Insulation that is fitted under the Flashing ... See Details at bottom of page.

**STEP 1**

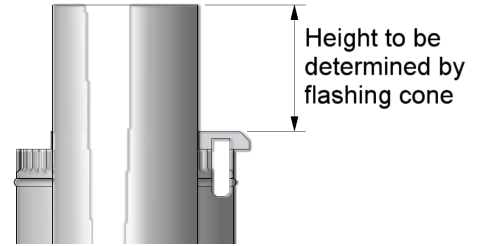

**STEP 2**

Flue 5mm Below Top Of Flashing Cone

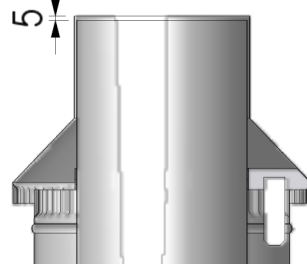

**STEP 3**

ADD Cowl Sits on Top of Flashing Cone, screw to secure

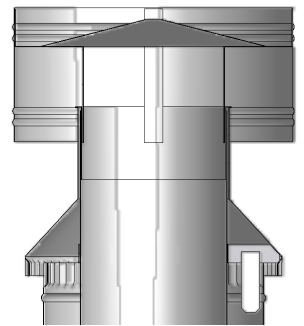

**“CHIMNEY CHASE FLASHING” AND “AIR VENTILATION” OPTIONS :**

**VENTING THROUGH CHIMNEY CHASE**

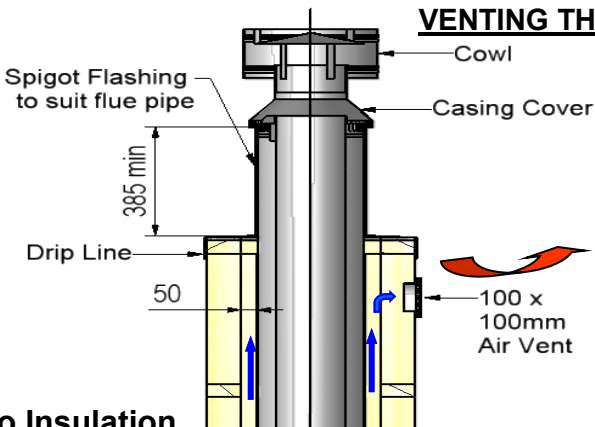

**“No Insulation under flashing”**

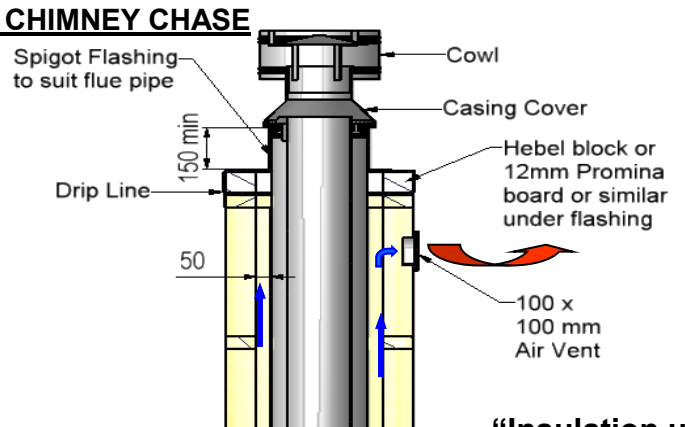

**“Insulation under flashing”**

**VENTING THROUGH FLASHING**

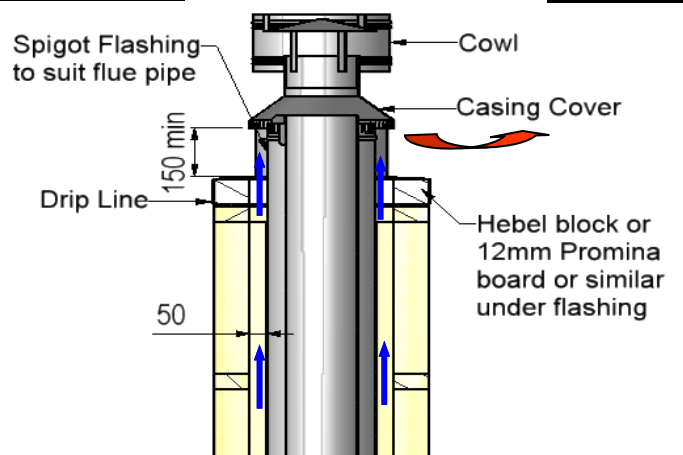
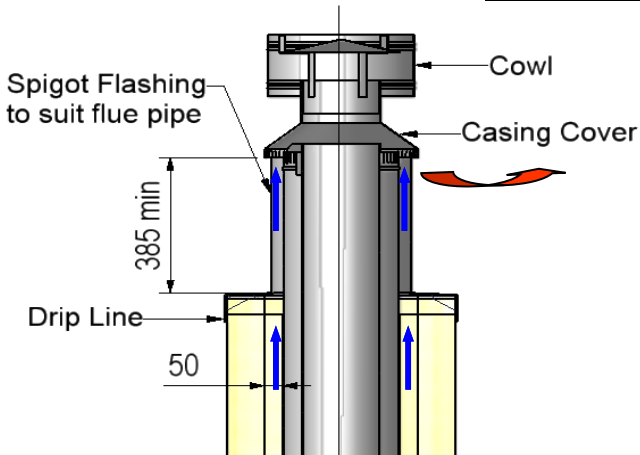



**FLUE HEIGHT MINIMUM DETAILS**

**Note: FLUE SYSTEMS Casing....**  
 Flue System may require to be Doubled Lined to comply.  
 Ref ASNZS:2918:2001 4.3 Flue pipe casing

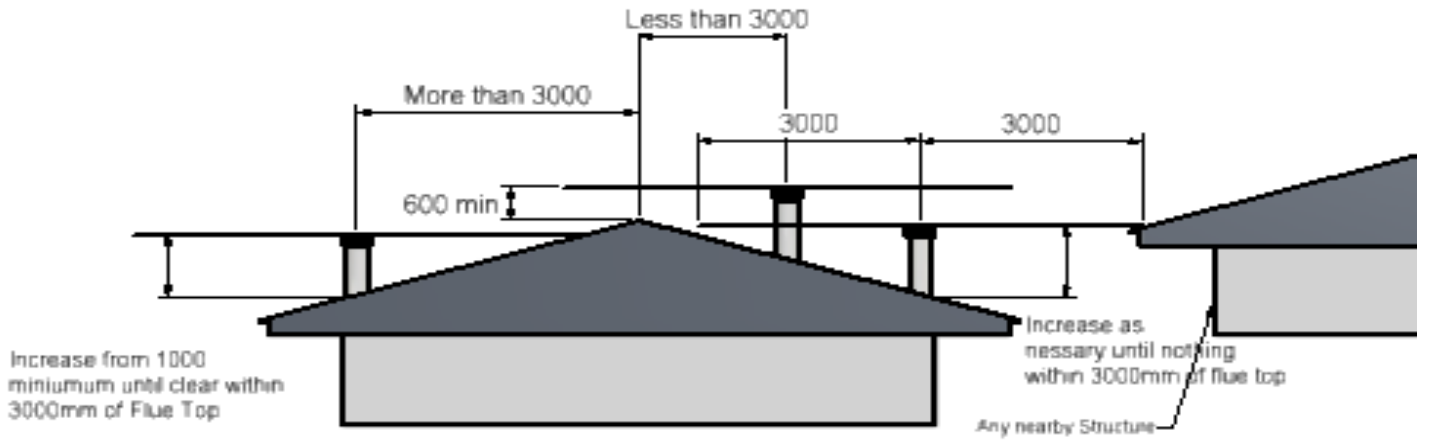

The flue exit is to comply to ASNZS 2918 : 2001

**3D View**

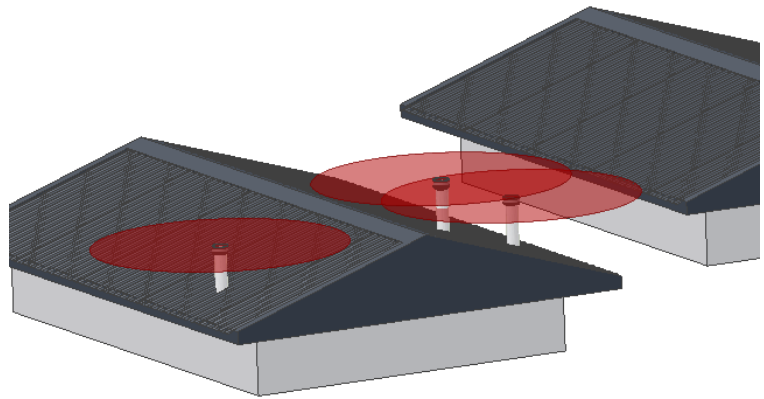

**FRAME OUT AND TRIM OUT DETAILS FOR CHIMNEY CHASE**

**Option X – Singled Lined Flue System**

**Option Y – Double Lined Flue System**

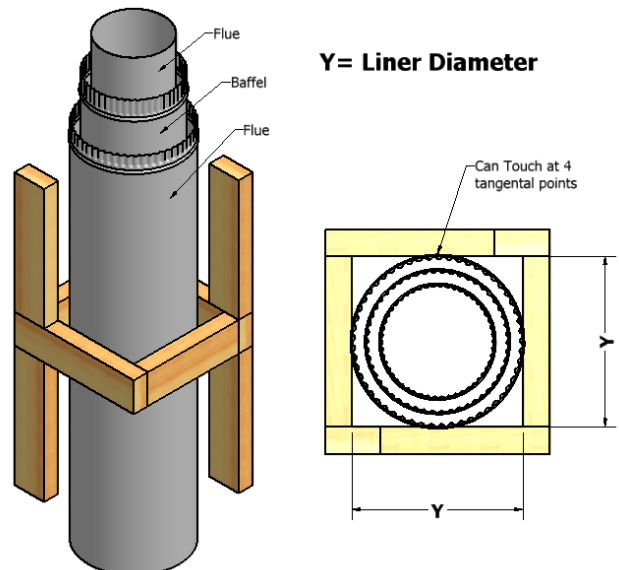
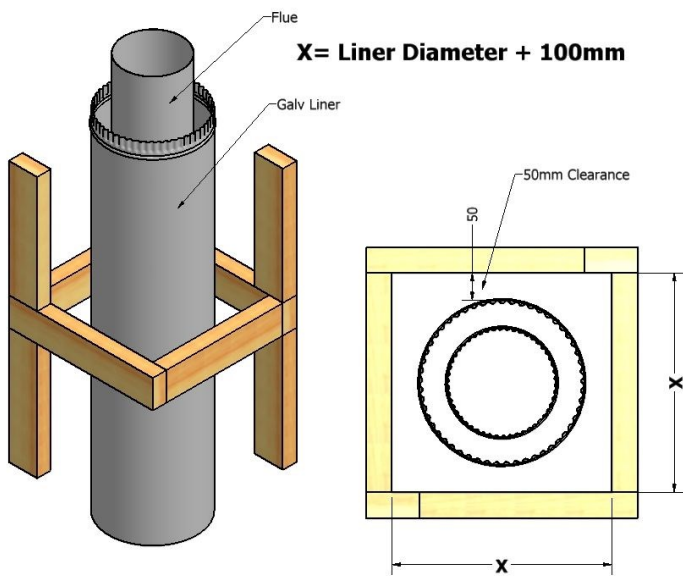

**COMBUSTIBLE MANTLE CLEARANCES**

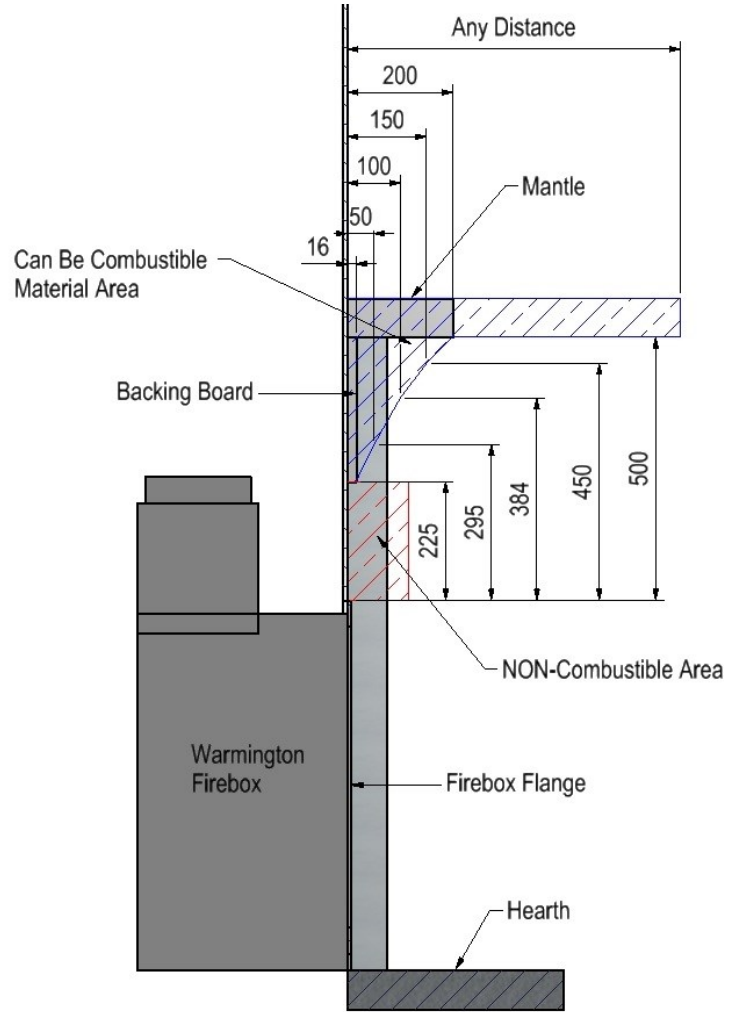
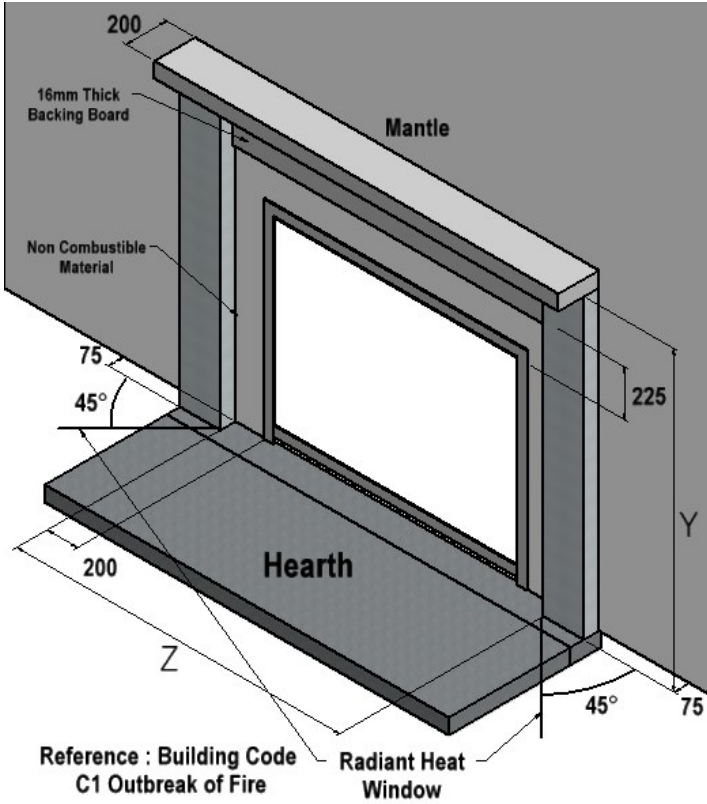

Mantle Clearances		
Firebox	Y	Z
SI 1250 SF	1525	1700
SI 1500 SF	1525	1950

**Note:**  
For Combustible Floors  
Minimum Hearth of 380mm (A) must be maintained.

**RAISED HEARTH CLEARANCES**

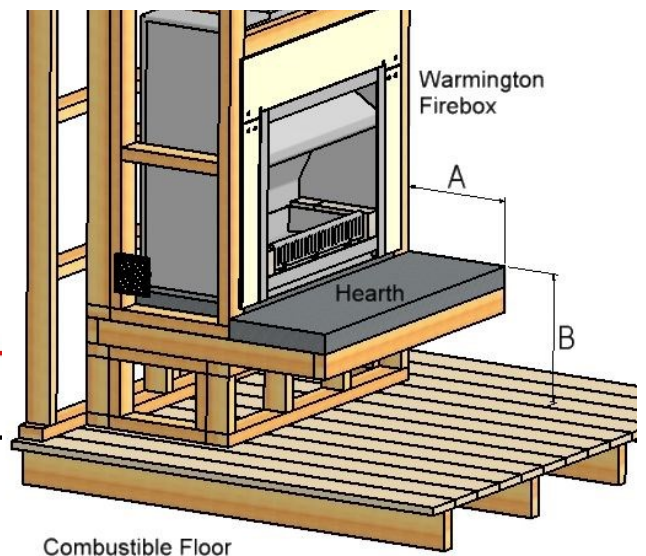
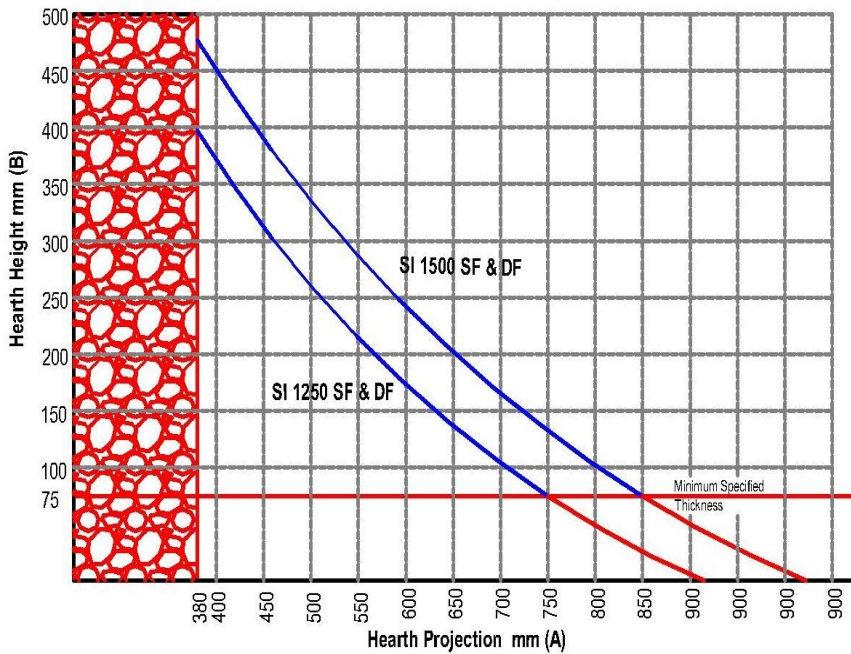

**GENERAL NOTES : ASNZS 2918 : 2001****NOTES:**

- Fire operation and maintenance instructions download from [www.warmington.co.nz](http://www.warmington.co.nz).
- Warranty - for full details on product warranties, contact your local Authorised Warmington Retailer.
- Correct installation, operation and maintenance must be maintained to comply with Warmington Warranty's. We offer a **12 month** guarantee on the fire back and **24 months** on the firebox, from the original date of purchase.
- The Appliance and Flue System must be Installed in accordance with ASNZS2918:2001 and all appropriate Building codes.

**WARNINGS:**

- **WARNING; ANY MODIFICATION OF THE APPLIANCE THAT HAS NOT BEEN APPROVED IN WRITING BY THE TESTING AUTHORITY IS CONSIDERED AS BREACHING AS/NZS 4013.**
- **WARNING; DO NOT USE FLAMMABLE LIQUIDS OR AEROSOLS TO START OR REKINDLE THE FIRE.**
- **WARNING; DO NOT USE FLAMMABLE LIQUIDS OR AEROSOLS IN THE VICINITY OF THIS APPLIANCE WHEN IT IS OPERATING.**
- **WARNING; DO NOT STORE FUEL WITHIN HEATER INSTALLATION CLEARANCES.**
- **WARNING; WHEN OPERATION THIS APPLIANCE AS AN OPEN FIRE USE A SPARK SCREEN.**
- **CAUTION: THIS APPLIANCE SHOULD BE MAINTAINED AND OPERATED AT ALL TIMES IN ACCORDANCE WITH THESE INSTRUCTIONS**
- **CAUTION: THE USE OF SOME TYPES OF PRESERVATIVE-TREATED WOOD AS A FUEL CAN BE HAZARDOUS.**

Model	Estimated KW	Average KW
1250 SF	30	14
1500 SF	35	14

**NOTE: For Operation instruction down load from the web site**  
[www.warmington.co.nz](http://www.warmington.co.nz)



**Industries 1994 LTD**  
**PO Box 58652, Botany 2163,Auckland [www.warmington.co.nz](http://www.warmington.co.nz)**