

Studio Oven

Studio Oven - Woodburner Installation Instructions

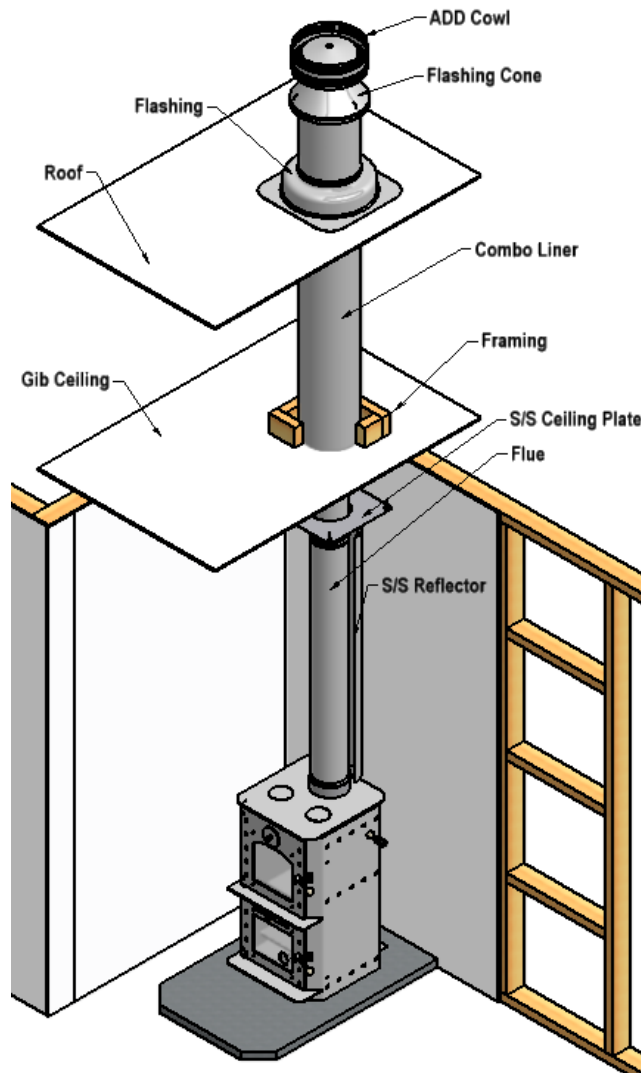

Visit www.warmington.co.nz for Spec's, DWG's and PDF uploads of Fires

Fire, Flue System and Instructions to Comply with ASNZS 2918:2001

Keep these Instructions for further reference.....Ensure that you have the correct and current Installation details for the Warmington Fire

Installation

The Warmington unit is to be Installed by a Certified Warmington Installer or an Approved NZHHA Installation Technician .
See www.homeheat.co.nz/members for a Certified NZHHA SFAIT Installer in your area .

CLEARANCES TO COMBUSTIBLE SURFACES UNLESS STATED

IMPORTANT

Read all the Instructions carefully before commencing the Installation. Failure to follow these Instructions may result in a Fire Hazard and void the warranty

Due to continued product improvement, Warmington Ind LTD reserves the right to change product specifications without prior notification.

All Dimension are in mm.....Copyright ©

Model: Studio Oven
Serial No: SO -
TESTED TO AS/NZS: 2918
TEST REPORT : JOHN YOLLAND & ASSOCIATES LTD
TEST REPORT NO : 98/17
Date of installation: ____/____/20____

Flue gas emission, power output and efficiency test

To comply with standard AS/NZS 4012:2014 and AS/NZS 4013:2014

47 Sir William Avenue, East Tamaki, Auckland.

PO Box: 58652 Botany, East Tamaki

Telephone +64 9 273 9227, Fax +64 9 271 0892

This accreditation does not extend to any opinions or any interpretations of test results contained in this report.

Test Report: W0101

Issue Date: 25/05/2016

Subject:

Sample description: Free standing wood burner

Make: Studio

Model: Oven

Standard Specification and scope:

1. AS/NZS 4012:2014 Domestic solid fuel burning appliances-Method for determination of power output and efficiency
2. AS/NZS 4013:2014 Domestic solid fuel burning appliances-Method for determination of flue gas emission

Content

The sample was tested as per the above instructions.

Summary

Efficiency and power was calculated using the loss-stack method in addition to taking into the consideration appliance & flue set-up, test fuel, preparation, fuel loading, burn rates & cycles, data recording intervals, wetback calculations and reporting of the results as stated in AS/NZS 4012:2014.

The solid fuel heater complied with the standard AS/NZS 4013:2014

Overall efficiency (%)	70
Space heating efficiency (%)	70
Water heating efficiency (%)	n/a
Emissions rate (g/kg dry weight)	1.50
Emission rate mg/MJ	99

More detailed test results are shown on page five to eight of this report.

Testing Completed 18/06/2016

Authorized Signatory

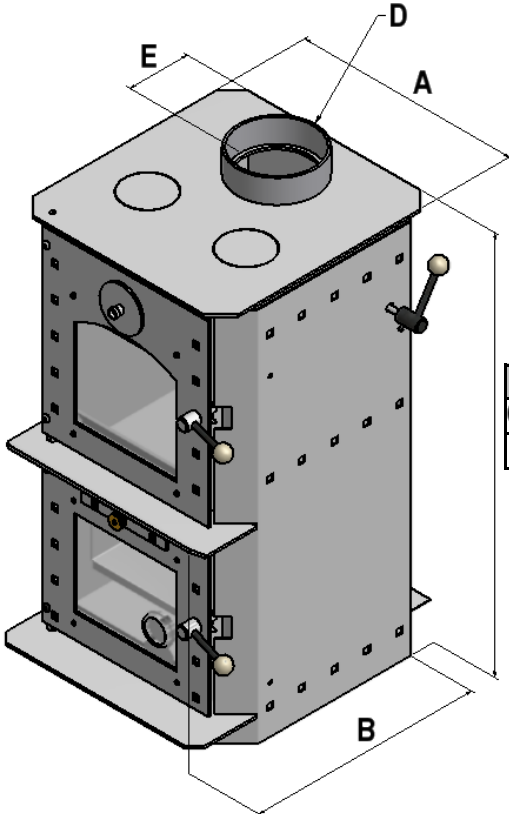

Tested by
Oystein Kalas

FIRE BOX DETAILS

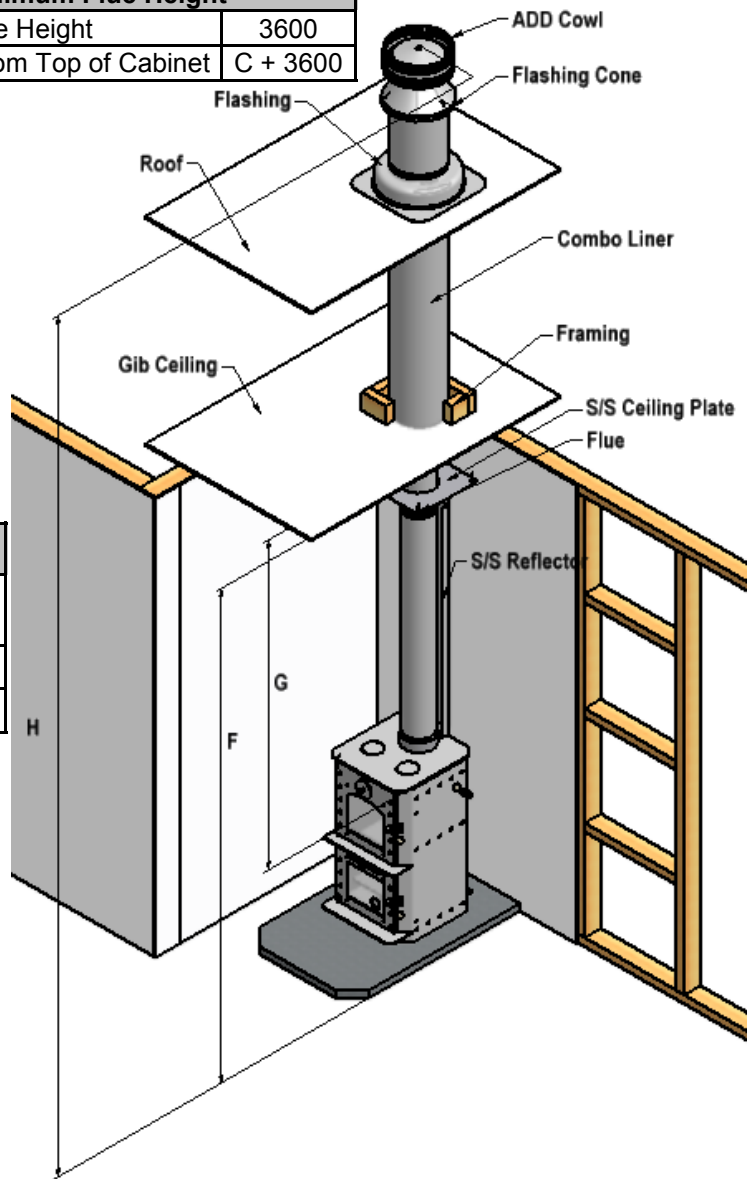

Description		
Cabinet Width	A	436
Cabinet Depth	B	509
Cabinet Height	C	820
Flue Diameter	D	150
To Flue Centre	E	123
Ceiling Height	F	2400
Minimum from fire to Ceiling	G	1500
Height from Floor Protector	H	4600

Minimum Flue Height	
C	Flue Height 3600
	Measured From Top of Cabinet C + 3600



FLOOR PROTECTOR

Note: Floor Protection
 Floor protectors are normally designed to suit each individual setting.
 The Studio Oven only requires an ash hearth
Floor Protector is to comply with AS/NZS 2918:2001

Check List:	
Fit Baffle (If required)	
Fit Bricks (If required)	
Fit Bottom Ash Pan	
Fit Top Plate Inspection Discs	
Fit Oven Trays	
Fit Thermometer	
Holding Down Brackets	
Check Door Seals	
Check Door Dampers	
Check Flue Damper & Handle	
Serial Number Check	
Loading Badge	
Packed By:	

Due to continued product improvement, Warmington Ind LTD reserves the right to change product specifications without prior notification.

All Dimension are in mm.....Copyright ©

PLAN VIEW OF CLEARANCES TO COMBUSTIBLES - STRAIGHT WALL INSTALL

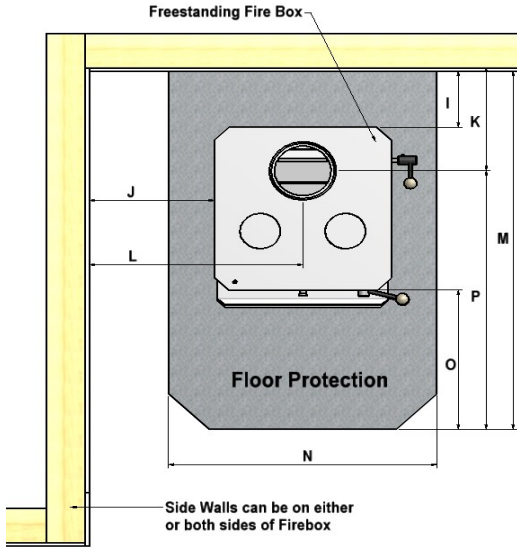

Description		1.	2.	3.
To Wall Behind	I	400	175	100
To Wall Side	J	330	305	100
To Flue Centre (Back)	K	525	300	223
To Flue Centre (Side)	L	550	525	300

Situation	
1.	Combustible surface without flue shield.
2.	Combustible Surface with stainless steel reflective flue shield. construction of flue shield must be in accordance with AS/NZS 2918 (minimum flue shield height is 1200mm).
3.	Non-combustible surface including walls, finishes and framing without flue shield, eg. concrete/block/brick/ACC block. Re clearance to a non-combustible materials, walls or surfaces ref to ASNZS:2918:2001 3.2.1. The clearance to a Non Combustible surface and including wall can be less that 100mm if a wet back is not fitted and no requirement for maintenance.

Description		1.	2.	3.
Hearth Depth	M	1125	900	823
Hearth Width	N	660	660	660
Hearth Projection from Centre of Flue	P	600	600	600

PLAN VIEW OF CLEARANCES TO COMBUSTIBLES - CORNER INSTALL

Description		1.	2.	3.
Hearth Projection	O	300	300	300
Hearth Projection from Centre of Flue	P	600	600	600
To Flue Centre – Corner	Q	580	380	303
To Wall Side – Corner	T	350	150	100

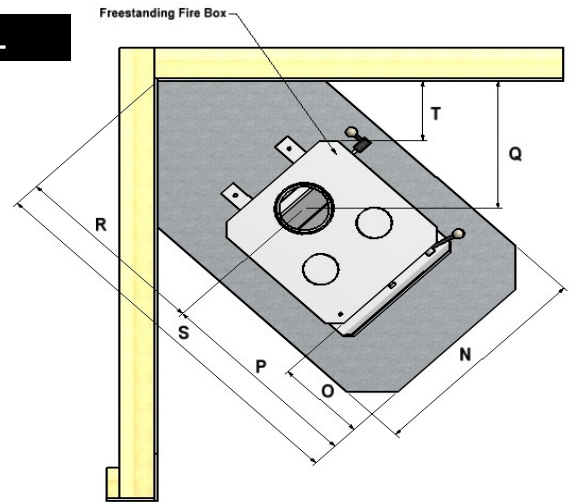

Description		1.	2.	3.
Hearth Depth	S	1420	1137	1029
Hearth Width	N	660	660	660
Hearth Projection from Centre of Flue	P	600	600	600

CLEARANCES TO BENCH TOP FOR STUDIO OVEN

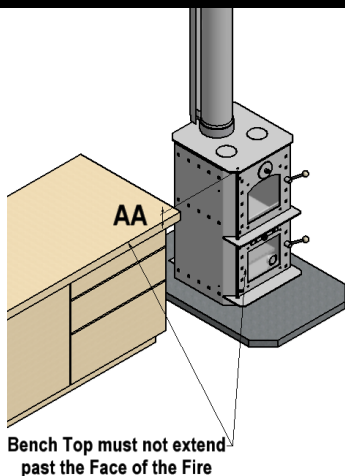

Description		mm
Bench Top Clearance	AA	50
To Bench Top Side	AB	352
To Flue Centre (Side)	AC	570

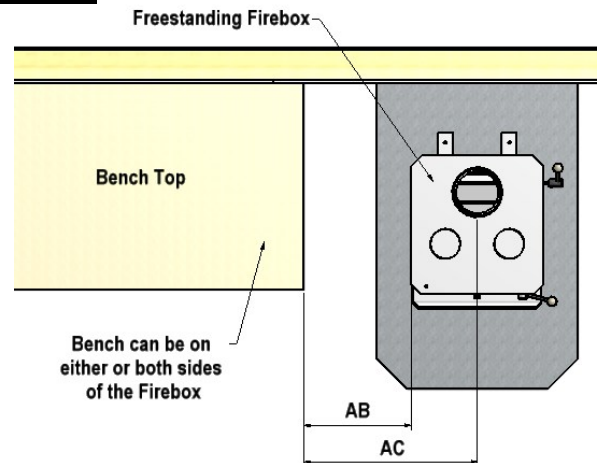

Due to continued product improvement, Warmington Ind LTD reserves the right to change product specifications without prior notification.

All Dimension are in mm.....Copyright ©

STUDIO OVEN INTERNAL MEASUREMENTS

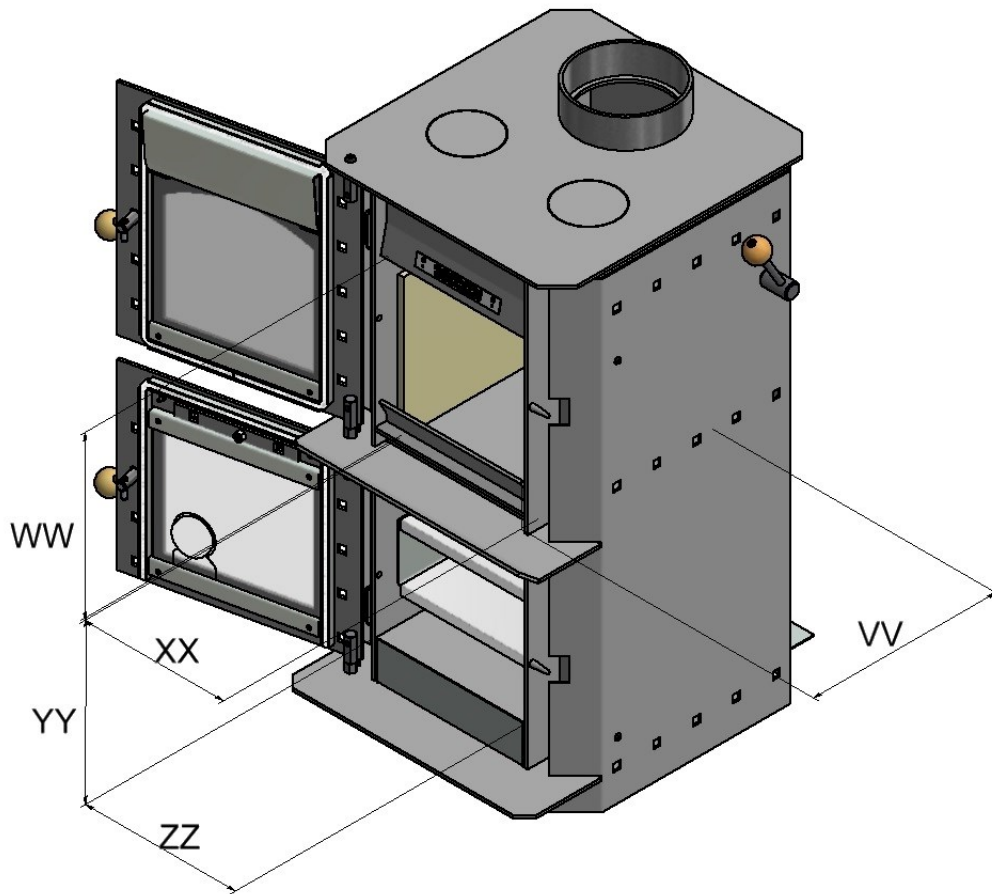

Description		STUDIO OVEN
Internal Depth	VV	295
Firebox Internal Height	WW	205
Firebox Internal Width	XX	241
Cooker Internal Height	YY	281
Cooker Internal Width	ZZ	260

Tested Fuel Load (Softwood)	Kg	Fire Box Litres: Approx.
STUDIO OVEN	up to 2.9 kg	29 Liters

Due to continued product improvement, Warmington Ind LTD reserves the right to change product specifications without prior notification.

All Dimension are in mm.....Copyright ©

WETBACK POSITION

STEP 1

Step 1:
Remove 2 x wetback plugs & fit wetback (as per diagram above) into 2 x holes inside firebox.

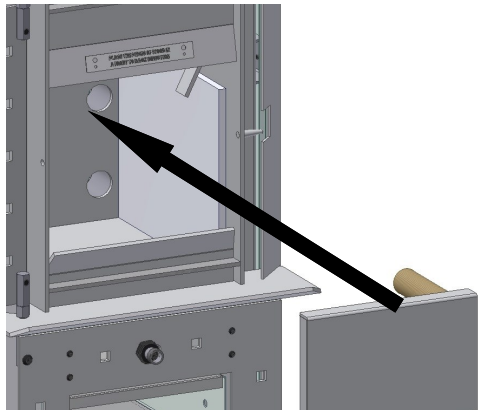

STEP 2

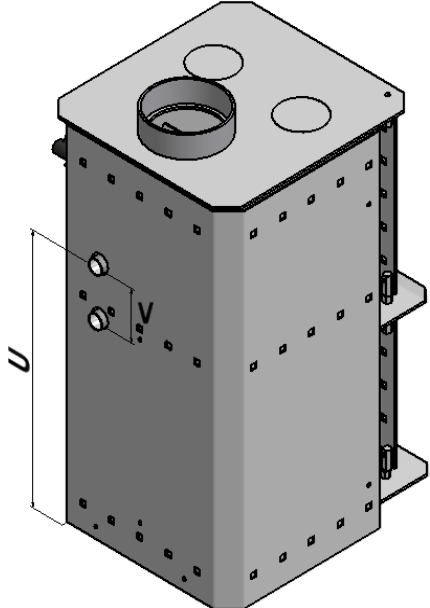

Note:
Cut excess BSP pipe off wet back to length.... by Plumber.

Power Out	KW*
Wetback	2 Kw
*Value is approx.	

STEP 3

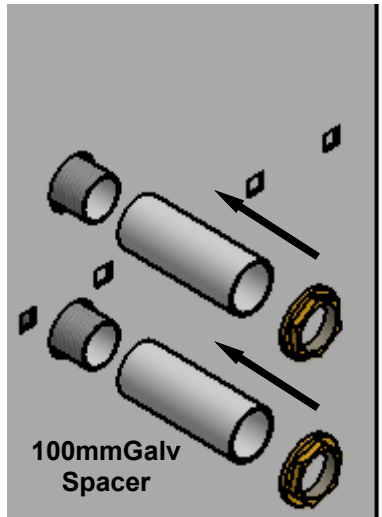

Step 2:
Once wetback is in place, the 2 BSP pipes should extrude out the back & past the fires main outer wrap.

STEP 4

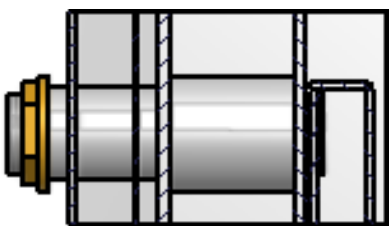

Description		
Height from bottom of unit	U	560
Distance between outlets	V	110

Step 4:
Once the wetback is secured in place, ensure that water is in the wetback before operating the fire. Damage will result if the wetback is dry.

Step 3:
With the 2X 100mm Galv spacer pipes supplied slide over BSP pipe off the wetback & then secure with 2X brass BSP nuts supplied.

Note:
Consult your plumber for wet back system configurations and operation.
Wet back is to be fitted to an internal heat-sync (e.g. Hot water cylinder / Radiator / Under floor heating etc...)
Ensure water is in the wetback before operating the fire. Damage will result if the wetback is dry.

DAMPER HANDLE FITMENT

STEP 1

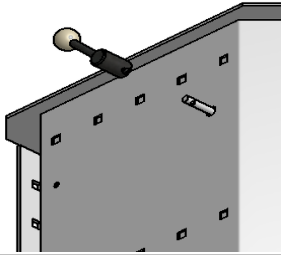

Step 1:
Slide Damper Handle over Damper Rod (Using a 3mm Allen Key Tighten screw into the Damper Rod Hole to secure in place)

STEP 2

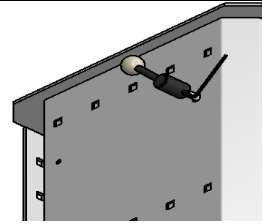

Step 2:
Align Screw on Damper Handle to the hole in the Damper Rod on the Top RH Side of the Studio Oven as shown. (Using a 3mm Allen Key Tighten screw into the damper rod hole to secure in place).

DAMPER ROD MAINTENANCE - HIGH TEMPERATURE GREASE (COPPER COAT)

STEP 1

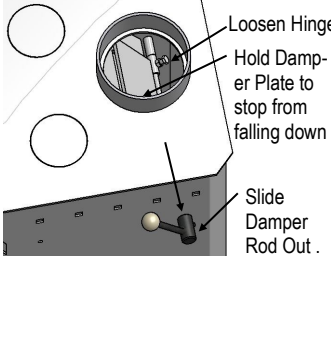

Step 1:
Lift or remove flue system from the fire to view the damper plate. On the damper plate there are 2 x hinge bolts, loosen these bolts & slide the Damper Rod out from the R/H side. Ensure to hold the Damper Plate to stop it falling inside back of the fire.

STEP 2

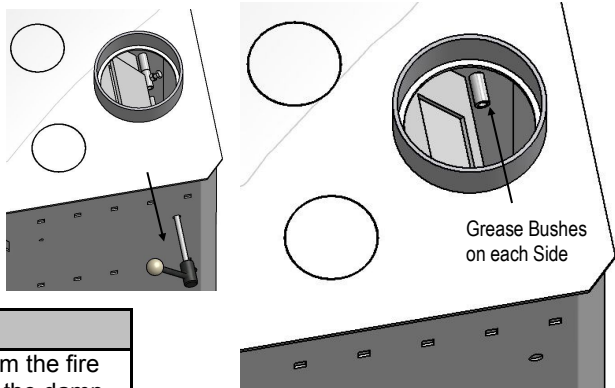

Step 2:
Grease end of hinge bushes & rod with high temp grease to ensure the damper rod maintains a free motion back & forth.

STEP 3

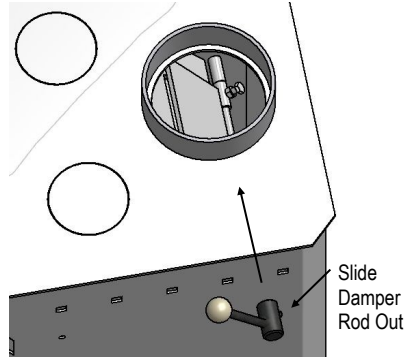

Step 3 :
Slide damper rod back in position through the Side of the Firebox, ensure to hold Damper Plate in position when sliding the Damper Rod back in place, & tighten the bolts, once set in same position as when you started.

SEISMIC RESTRAINTS

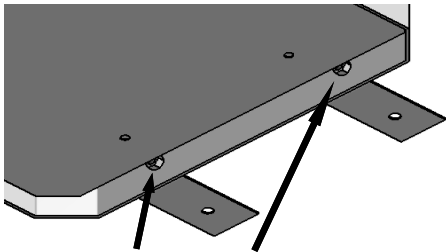

Step 1:
Lean fire over to bolt seismic restraints to main outer wrap on the back, bottom, inside as shown above.

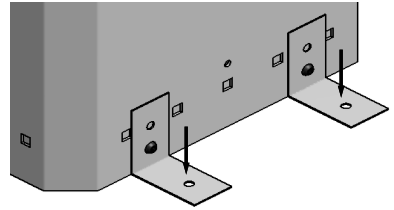

Step 2:
Secure fire down at 2 x lugs as shown. **Seismic Bolts not supplied.**

Seismic Restraint Fixing Instructions
Fix 2 x seismic restraints through the hearth into the floor. Ensure they penetrate into the fixing by at least 3 times their diameter.
Use at least 2 x 6 to 8 mm Dia Dyna Bolts or similar to fix fire to hearth and or through the hearth to the floor.
Fix hearth to floor with appropriate adhesive, bolt or screw.
Ensure that the Seismic Restraint complies with AS/NZS 2918:2001 — Ref 3.8

Due to continued product improvement, Warmington Ind LTD reserves the right to change product specifications without prior notification.

All Dimension are in mm.....Copyright ©

STUDIO OVEN PROMINA BRICK FITMENT

PROMINA BRICK FITMENT - STEP 1

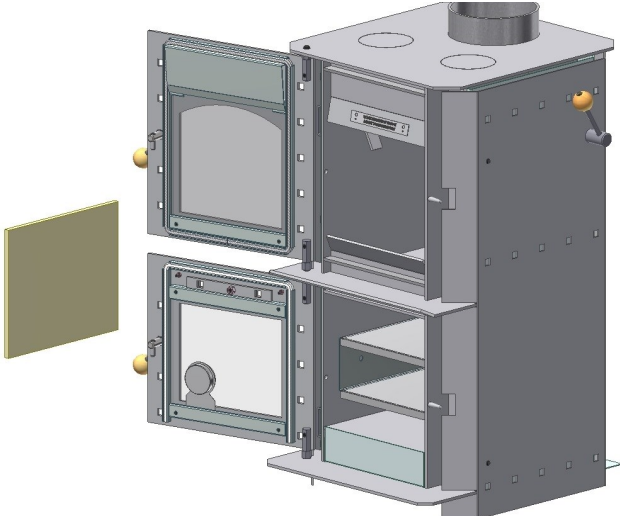

Fit one side brick first.
Sitting it hard against the and side walls of the firebox. The Brick will clip under the hook on the side wall of the fire box
There should be a gap from the front.

Cut Down
25mm



Wet Back Plugs

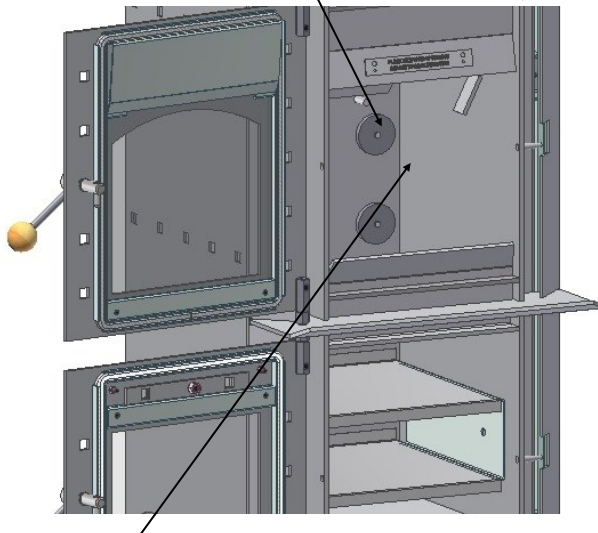

Note:
STUDIO OVEN: The bricks will need to be cut down in length to allow for the wet back to be fitted.

PROMINA BRICK FITMENT - STEP 2

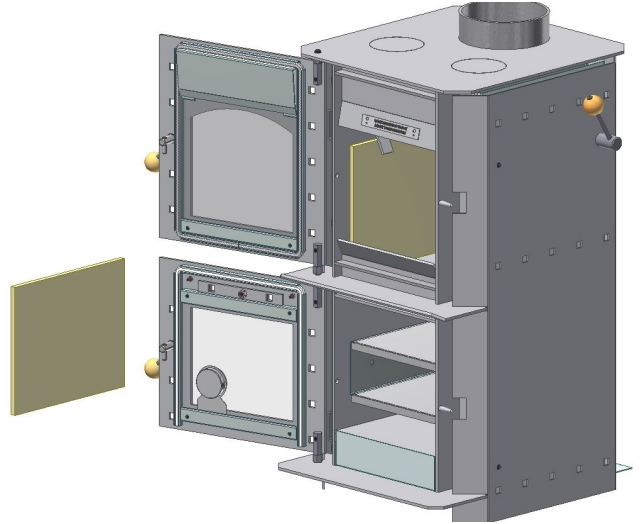

Fit the second side bricks.
Sitting it hard against the and side walls of the firebox. The Brick will clip under the hook on the side wall of the fire box
There should be a gap from the front.

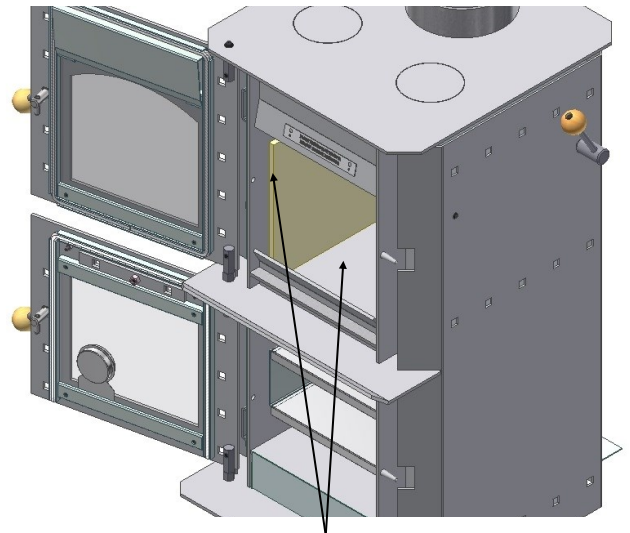

Note:
Once fire is operational and ash is in the base of the firebox, the bricks will be supported.

OPERATING INSTRUCTIONS FOR THE STUDIO OVEN

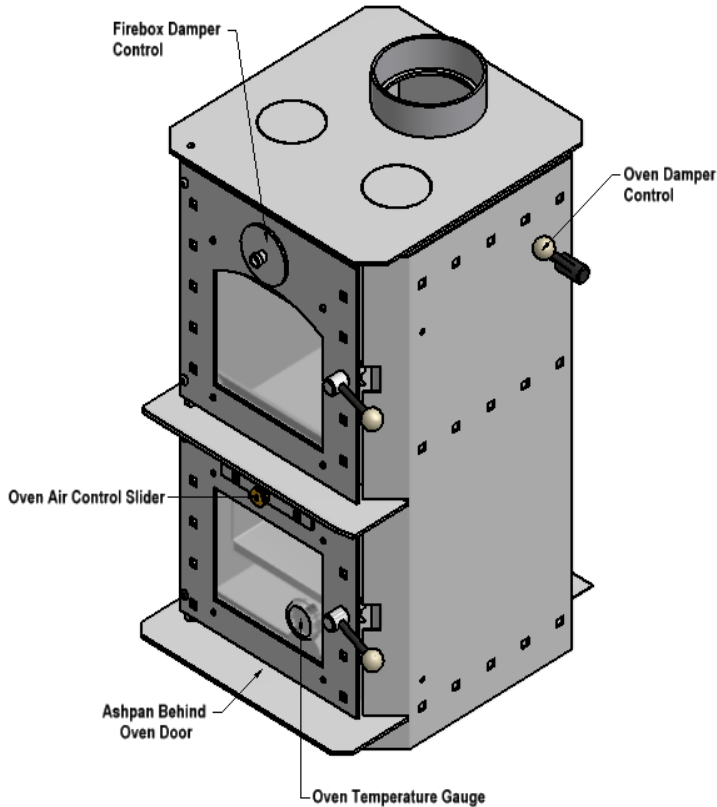

The Oven is heated directly by the Fire. In order to heat up the oven, the Fire should be lit as described in our Specifications. Once the Fire is established, pull the Oven Damper handle Forward. This will allow the Hot Fumes from the Fire to circulate around the Inner cavity thus heating up the Oven.

To Maximize the Heat from the Fireplace into the Home, operate the Oven by having the Damper Control on the side to the forward position. To Reduce the Heat going to the Oven, the Oven Damper Control should be pushed to the upright position backward. This will allow the Hot Fumes to escape directly up the Chimney, thus reducing the heat to the oven. **Do not run the fire for long periods with the door ajar as damage may result.**

The Oven Air Control Slider on the Oven Door will allow small amounts of air to escape when the Air Control is opened. This is a fine adjustment only, & you will find that in time operating the firebox wood load, Oven Damper Control & the Oven Air Control Slider together, you will

TEMPERATURE GAUGE REMOVAL TO CLEAN

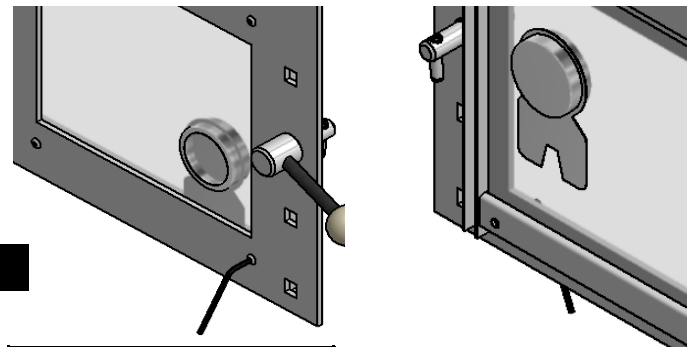

Step 1:
Open bottom Oven Door & loosen 2 x glass bracket cap Screws with 3mm allen key as shown.

Step 2:
Remove temperature gauge as shown.

OPERATION OF THE OVEN TEMPERATURE GAUGE

The temperature gauge on the Oven door provides an indication of Oven Temperature. It should be noted however, that since the gauge is attached to the door, temperatures may drop if the Oven door is left open for a prolonged period of time. Once the Oven door is closed again the gauge will come back to temperature shown.

CLEANING THE STUDIO OVEN

The Studio Oven should only be cleaned when it is not being Used. The exterior can be dusted with a firm brush. Do not use a cloth to clean, as this will drag on the paint finish leaving a lint on the surface.

As the cooking stove top is used for cooking, normal wear and tear will occur. Spills should be mopped up immediately with a damp cloth, but oven cleaners should not be used as they are too abrasive.

The exterior of the Studio Oven is painted with a high temperature cooking stove paint, and from time to time it may become necessary to renovate the exterior by repainting. The surface must be prepared by rubbing down with a wire brush. The cooking stove paint will not adhere to the surface if there are fat deposits or food particles on the area to be resprayed. High temperature cooking stove paint is available from **Warmington**. Do not use this paint until the Cooker is completely cold and always follow the instructions on the container before starting to paint.

The glass door should stay relatively clean if the correct type of fuel is used, but from time to time this can be cleaned when cold with a proprietary glass cleaner and a dry cloth, or depending on the soot build up, a nylon pan scourer.

OVEN DIMENSIONS:

Oven Door Opening	256mm x 260mm
Oven Width	260mm
Oven Depth	320mm
Oven Height	281mm

Due to continued product improvement, Warmington Ind LTD reserves the right to change product specifications without prior notification.

All Dimension are in mm.....Copyright ©

CHIMNEY SWEEPING

STEP 1

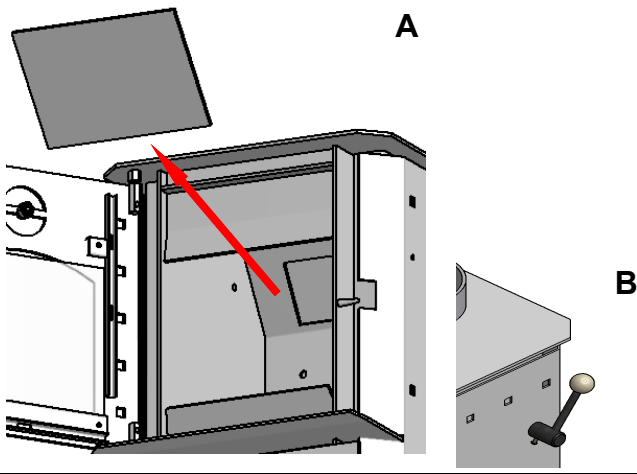

STEP 2

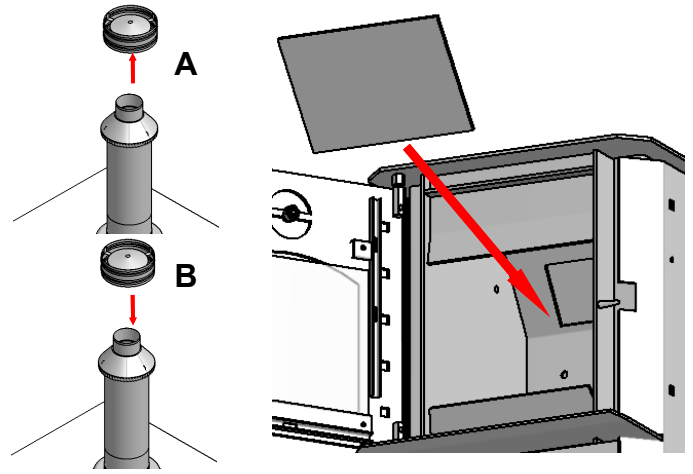

Step 1 :
 Remove Baffle from top Firebox, as shown in diagram A. Close both doors to stop any soot coming into the room. Open the Oven Damper Control on the R/H top side of the Fire, as Shown in Diagram B.

Step 2 :
 Remove ADD Cowl on roof (dia A) & sweep with suitable sized chimney sweeping brush to flue diameter, from the top down. When finished, replace ADD cowl securely (dia B).. Once flue is swept, clean out ash & soot from the firebox & replace baffle plate (dia C).

CLEANING OUT SIDE CHANNELS / SOOT & DEPOSITS

STEP 1

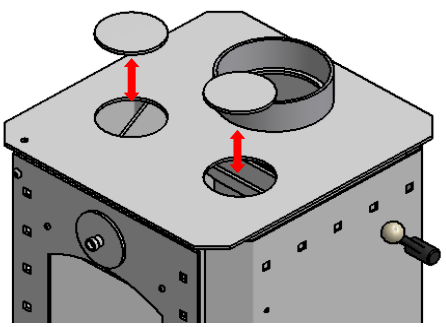

STEP 2

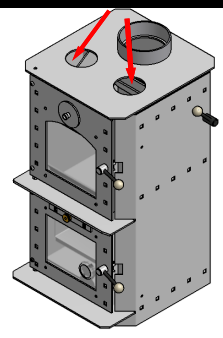

Step 1:
 Ensure fire is out. Remove 2 x inspection caps from the top plate as shown in Diagram

Step 2:
 With both doors closed, sweep out 2 x side channels with a 100mm dia chimney sweeping brush or equivalent tool until channels are clear of any soot etc.

STEP 3

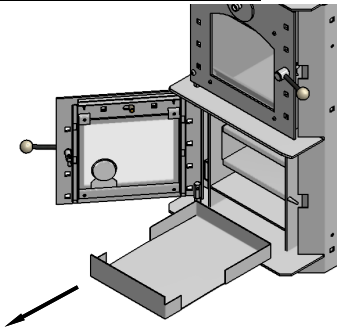

STEP 4

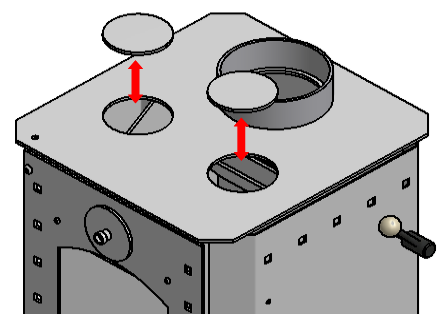

Step 3:
 Open bottom Oven door & slide out ashpan at the bottom, empty ash etc. & place back in position & close door.

Step 4:
 Replace caps back in position & the fire is ready to use.

Due to continued product improvement, Warmington Ind LTD reserves the right to change product specifications without prior notification.

All Dimension are in mm.....Copyright ©

FLUE SYSTEM INSTALLATION GUIDE

Note: FLUE SYSTEMS casing.
 Flue system may require to be doubled lined to comply. Ref ASNZS:2918:2001 4.3 Flue pipe casing

Minimum Flue Height	
Flue Height	3600
Measured From Top of Fire	C + 3600

Flue details	No:	Studio
Cowl	1	150
Cone	1	150
Top Spider	1	150
Liner Diameter Slip	1	250
Flue Diameter S/S	1	150
Flue Diameter Hi Therm Black	2	150
Combo 250/200 X 1200MM Galv	1	250
Ceiling Plate	1	150
Ceramics	4	
Double Flue Shield with Brackets	1	to suit150

NOTE:
 Ensure that a Standard Tested Warmington Flue system is used on the Warmington fires.

This flue kit has been manufactured in accordance with AS/NZS 2918:2001 and tested to Appendix F. To ensure safety, this flue kit must be installed as outlined in these instructions. Heater and flue pipe clearances from combustible walls must be in accordance with heater manufacture's specifications and AS/NZS 2918:2001. These installation instructions are for tested appliances only.

THIS IS A GUIDE ONLY—EACH INSTALLATION WILL VARY DUE TO UNIQUE INSTALLATION REQUIRMENTS.

- STAGE 1:** Locate heater in its proposed position and mark a point on the ceiling that is directly above the centre of the heater's flue outlet. Check that the heater's location allows the **Outer Casing** to clear all structural roof timbers.
 - STAGE 2:** Cut a 250mm square hole in ceiling. Directly above, cut a hole in roof to accommodate **Outer Casing**.
 - STAGE 3:** Fit timber nogs around ceiling and roof holes, i.e. Nogs form a 250mm square aperture, which allows air to circulate freely over the **Outer Casing** surface.
 - STAGE 4:** Position the **Outer Casing** so that it is flush with the underneath of the ceiling and protrudes through the roof the required height (Refer to AS/NZ 2918:2001 if more details are required. When calculating roof penetration height, allow for an extra 500mm that can be achieved by using the **Outer Casing Slip Extension**.
 - a: If the flue is within three metres of the ridge, the **Outer Casing** must protrude at least 600mm above the ridge of the roof.
 - b: If the distance from the ridge is more than three metres, the **Outer Casing** must protrude at least 1000mm above roof penetration.
 - STAGE 5:** Fix an appropriate flashing around the **Outer Casing** to seal onto the roofing material.
 - STAGE 6:** Assemble **Flue Pipes** together ensuring seams are in line. Secure each joint with three rivets or self-tapping screws. **Flue Pipes** must be assembled with crimped ends down (towards heater).
 - STAGE 7:** Place **Ceiling Plate** over heater flue spigot, ensuring the folded edge up stands are facing ceiling.
 - STAGE 8:** From the roof, lower **Flue Pipes** through **Outer Casing** into position. Ensure not to scratch the Hi Therm Flue coating. The Hi Therm Coating can be touched up with an approved Spray can (Stovebright). **NOTE: Some fires require the crimped end of the flue that fits into the Fires flue spigot to be trimmed back to from a snug fit. Seal flue to Fire box spigot.**
 - STAGE 9:** From the roof, slide the **Inner Casing** into the **Outer Casing**, around the flue, until it rests 12mm above ceiling level on the **Swage Ring of the Outer Casing**.
 - STAGE 10:** Before securing the **Outer Casing Slip Extension** to the **Outer Casing** with three rivets or self tapping screws, ensure the **Flue Pipes** extends above the top of the **Outer Casing Slip Extension** 145mm APPROX. The fitment of the **Cowl**, **Flashing Cone** and **Flue** is required to form a seal by the flange on the **Cowl**. Adjust **Slip Extension** to obtain this measurement. If minimum roof penetration heights described earlier can not be achieved, add sufficient stainless steel **Flue Pipe**.
 - STAGE 11:** Fit **Top Spacer Bracket** to the **Flue Pipe** making sure the lugs fit snugly inside **Outer Casing Slip Extension**. Make sure **Top Spacer Brackets** fits hard down onto **Outer Casing Slip Extension**.
 - STAGE 12:** Fit **Flashing Cone** over the **Flue Pipe** and push down firmly onto **Top Spacer Bracket**. Optional to secure with a rivet or self-tapping screw. The **Flashing Cone** should be flush with or 5mm above the finished **Flue Pipe**.
 - STAGE 13:** Fit **ADD Cowl** but do not secure permanently, as removal for flue cleaning will be necessary. The **Cowl** will fit tight down onto the **Flashing Cone** forming a seal—ensure that the seal is formed. (The **Cowl**, **Flashing Cone** and **Flue** can be secured with a Stainless Steel screw but provision must be made for the removal of the **Cowl** for cleaning of the flue system.
 - STAGE 14:** Fasten **Ceiling Plate** to ceiling using screws and spacers provided. Ensure an even air gap around **Flue Pipe** when fixing. Remove protective plastic from **Ceiling Plate**.
N.B. 12mm air gap between ceiling plate and ceiling must be maintained.
 - STAGE 15:** Fit of the Flue Shield, fit **Bracket** to **Flue Pipe** above firebox and the bracket into the flue spigot on the fire.. Attach **S/S Reflector to brackets**, ensure that the plastic coating is removed from all the surfaces before lighting the fire.
- N.B.** It is the responsibility of the installer to ensure that the installation of the flue kit complies with AS/NZ 2918:2001, the appliance manufacture's specifications for flues and that relevant Local Body requirements are adhered to.

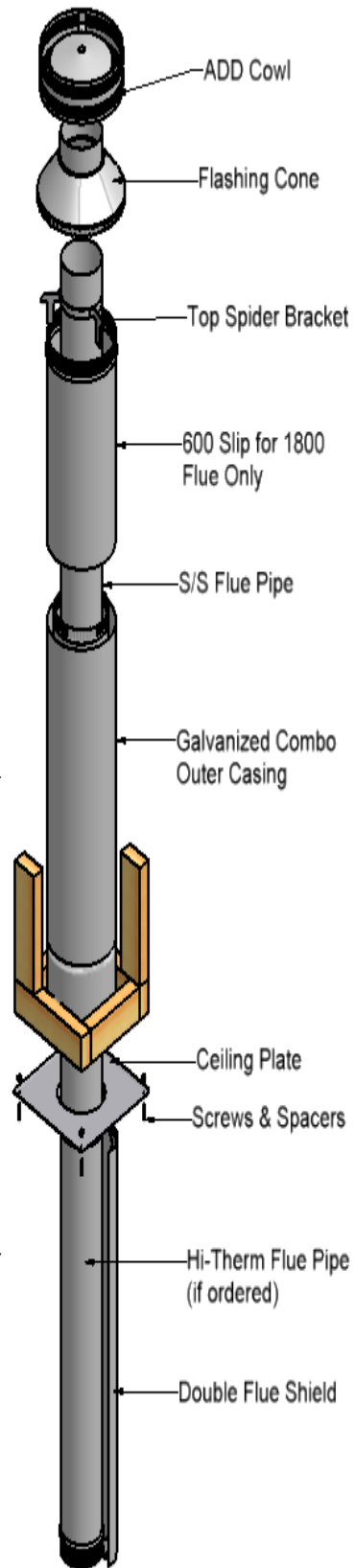

Due to continued product improvement, Warmington Ind LTD reserves the right to change product specifications without prior notification.

All Dimension are in mm.....Copyright ©

FLUE HEIGHT MINIMUM DETAILS

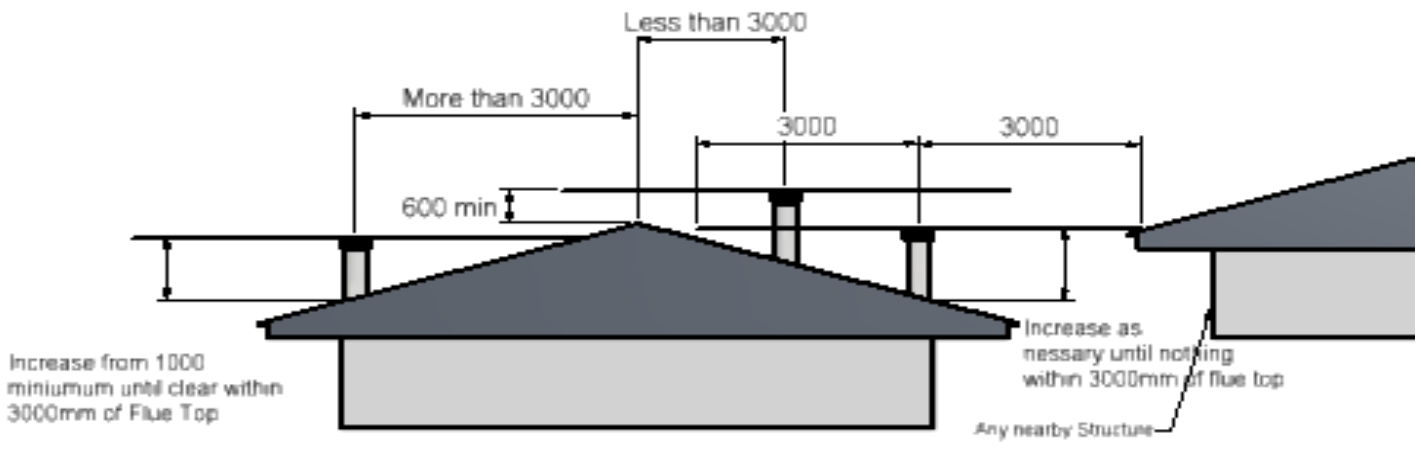

The flue exit is to comply to AS/NZS 2918: 2001

3D View

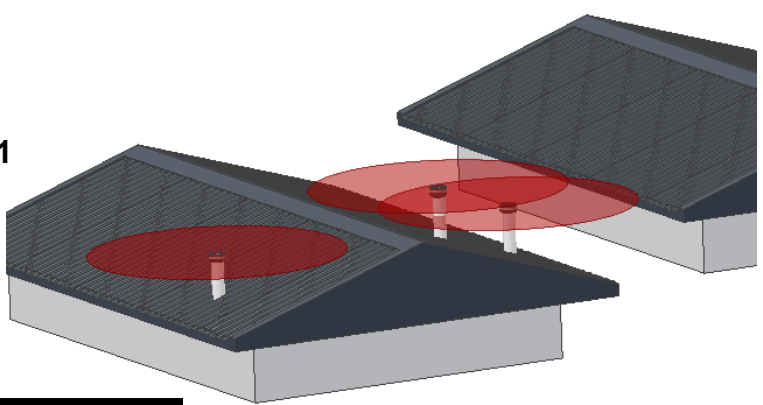

FLASHING - TO COMPLY TO THE BUILDING CODE (E2)

FRAME OUT - TRIM OUT DETAILS FOR FLUE SYSTEM

Note: ROOF FLASHINGS GENERAL
 Flashing are to be complaint to the building code and the design will vary depending on the type of roof.
 Each installation is unique and your Installer will advise of the most appropriate flashing method to comply.

Note: FLUE SYSTEMS casing.
 Flue system may require to be doubled lined to comply. Ref AS/NZS:2918:2001 4.3 Flue pipe casing

Note :

External Requirements
 Refer to AS/NZS2918:2001 4.9.1

Install Flue system to AS/NZS2918:2001

When using a rubber or Bitumen flashing (Butynol, Dectite) an Additional Flue pipe Baffle is required.

All external air vents & ceiling penetrations must be bird proofed with permanently fixed screens.

All flashing to comply with E2.

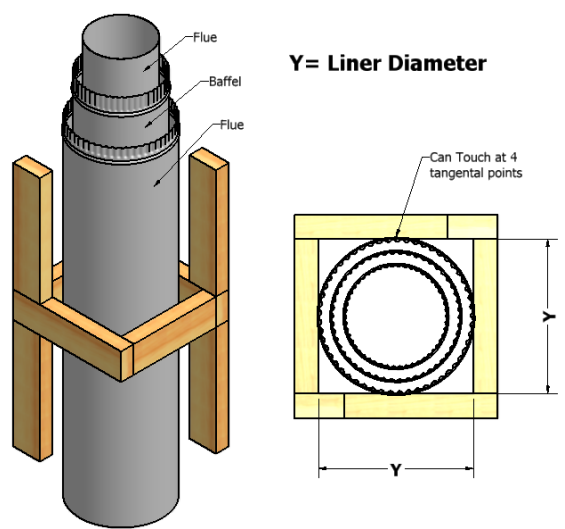

Due to continued product improvement, Warmington Ind LTD reserves the right to change product specifications without prior notification.

All Dimension are in mm.....Copyright ©

Studio Oven Door Glass Fitment

No : 1

The Studio Door glass is a special heat resistance glass designed for use in fires.

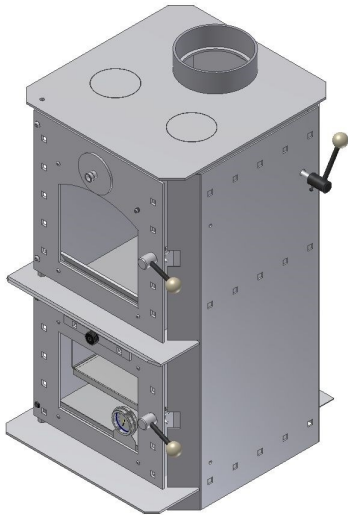

No : 2

The glass can be replaced with the door still fitted to the fire. Loosen the 4 Cap screws on the front of the door that retain the glass and remove the bottom glass retainer .

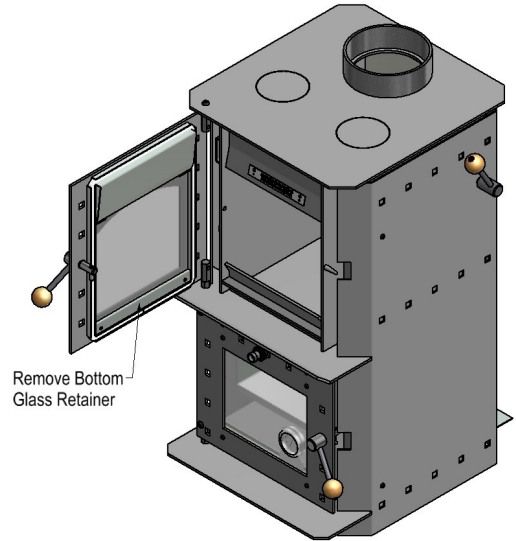
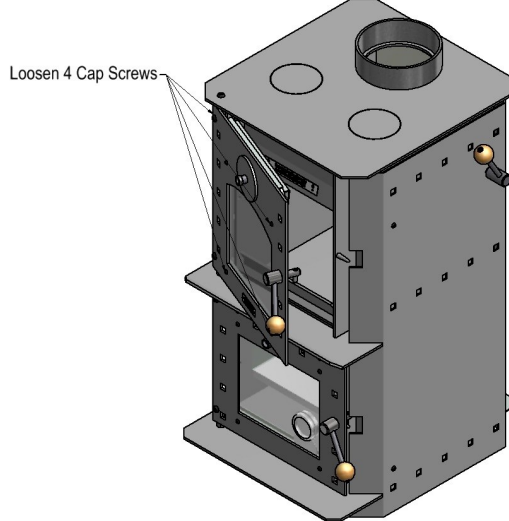

Parts		Tools	
Warmington Studio Door Glass	1 x	3mm Allen Key	1 x

No : 3

Slide the glass down towards the bottom glass retainer and remove the glass and any shards.

No : 4

Ensure that both glass & door surfaces are clean and true .

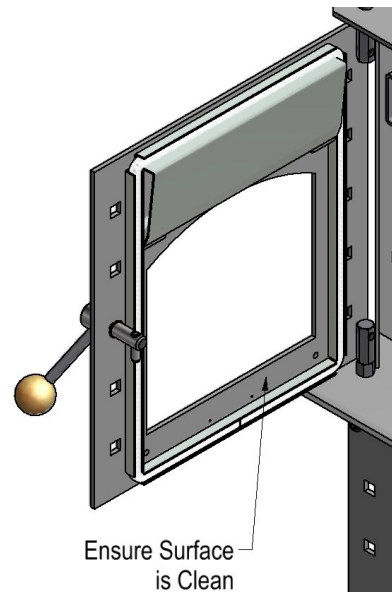
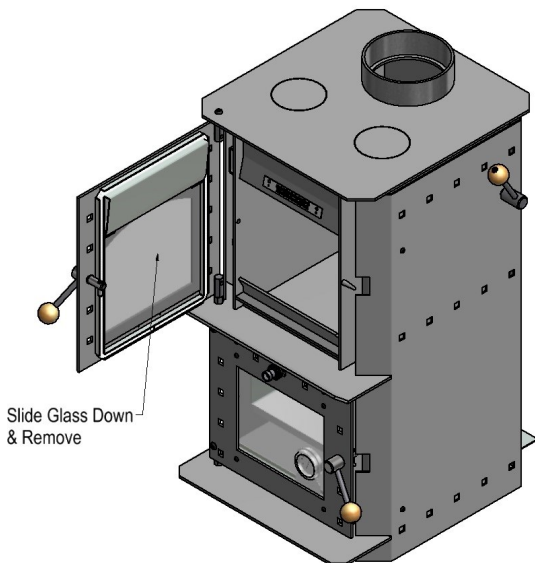

Due to continued product improvement, Warmington Ind LTD reserves the right to change product specifications without prior notification.

All Dimension are in mm.....Copyright ©

No : 5

Place the new glass into the door at the bottom.

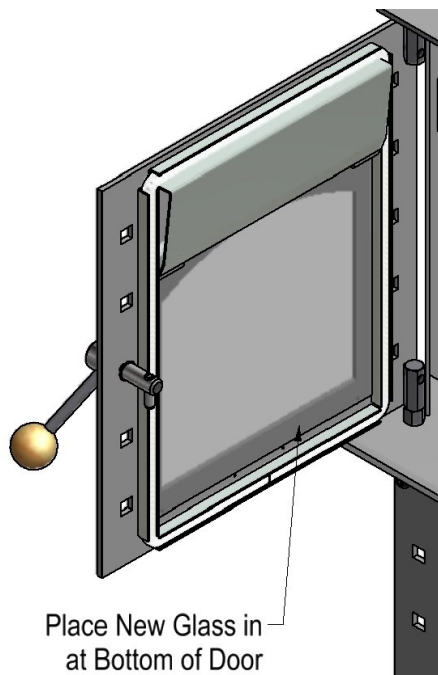

Place New Glass in at Bottom of Door

No : 6

With a 3mm Allen key, hook under the air dam and lever the top door retainer up, at the same time slide the glass up and under the top door retainer. Repeat for the other side.

NOTE :

Take Care not to Break Glass .

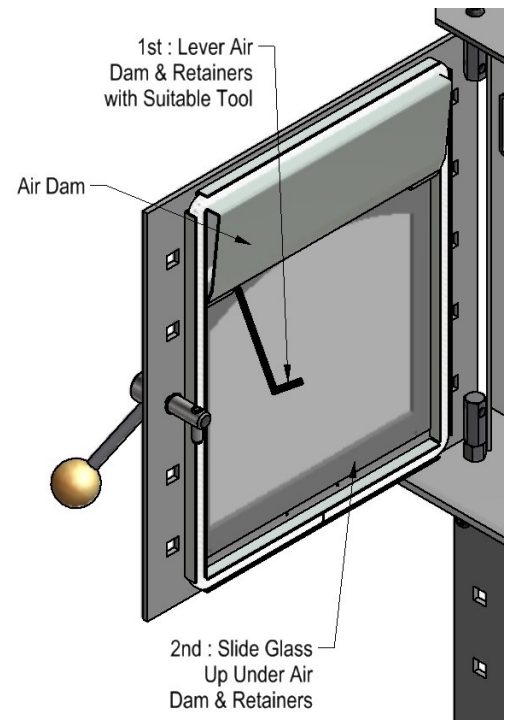

1st : Lever Air Dam & Retainers with Suitable Tool

2nd : Slide Glass Up Under Air Dam & Retainers

No : 7

Slide the glass up and into position, ensure that the bottom Glass retainer holes are clear to take the cap screws. Fit the bottom glass retainer.

No : 8

IMPORTANT NOTE :
Nip up the cap screws for the Top and Bottom glass retainers.
DO NOT OVER TIGHTEN AS GLASS MAY CRACK/BREAK .

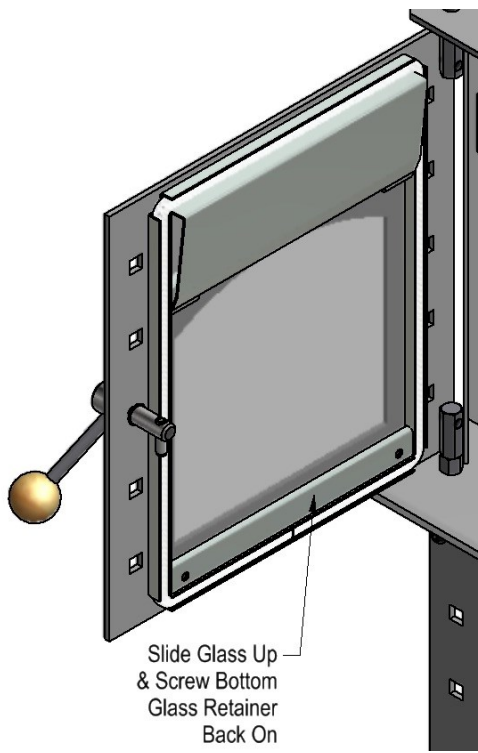

Slide Glass Up & Screw Bottom Glass Retainer Back On

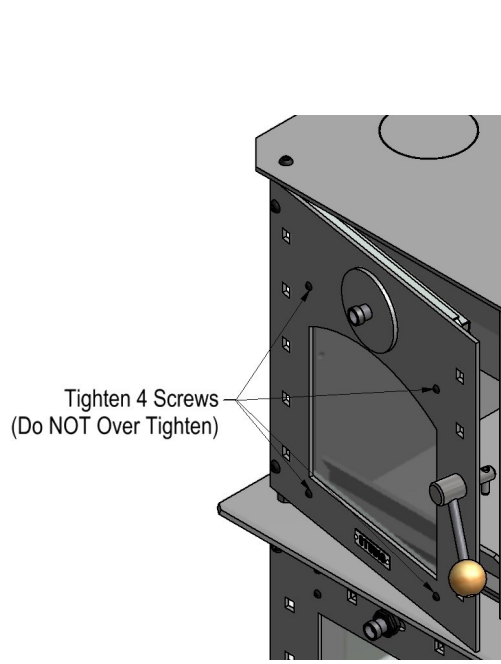

Tighten 4 Screws (Do NOT Over Tighten)

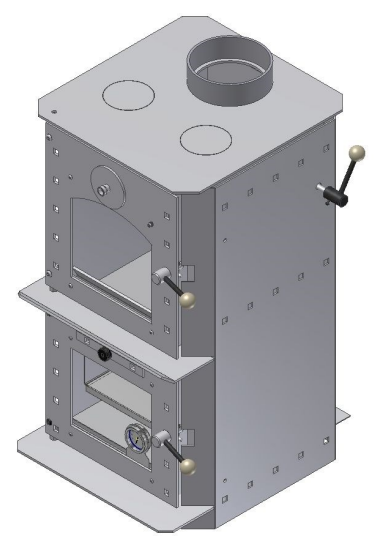

Due to continued product improvement, Warmington Ind LTD reserves the right to change product specifications without prior notification.

All Dimension are in mm.....Copyright ©

Studio Oven Door Adjustment Instructions

No : 1

The Studio Door and Hinge has been designed to give a wide range of Adjustment.

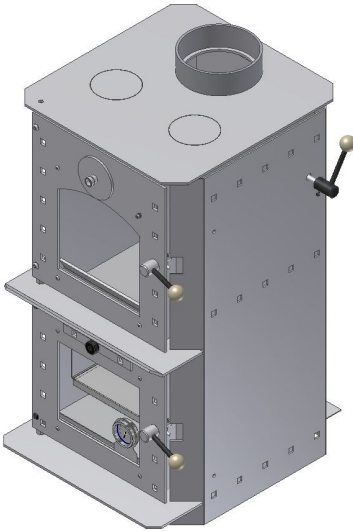

No : 2

Have all the Screws and the Nuts just loose so the door can move with a slight force.

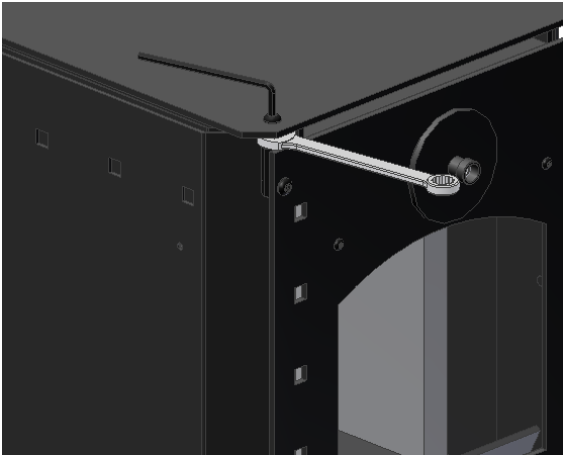

No : 3

Close the Door and nip the handle closed . Ensure that the handle is only just nipped.

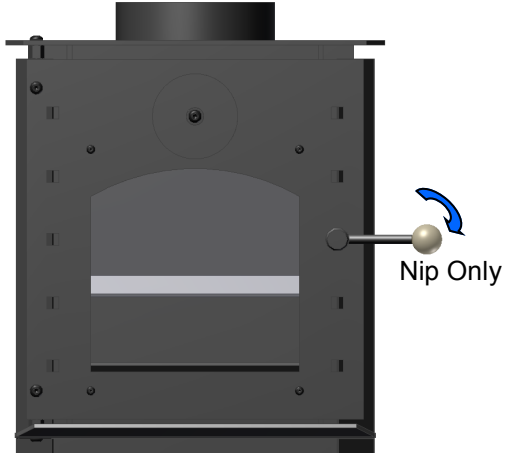

No : 4

Line up the Door across the Top of the Fire and ensure that it is parallel

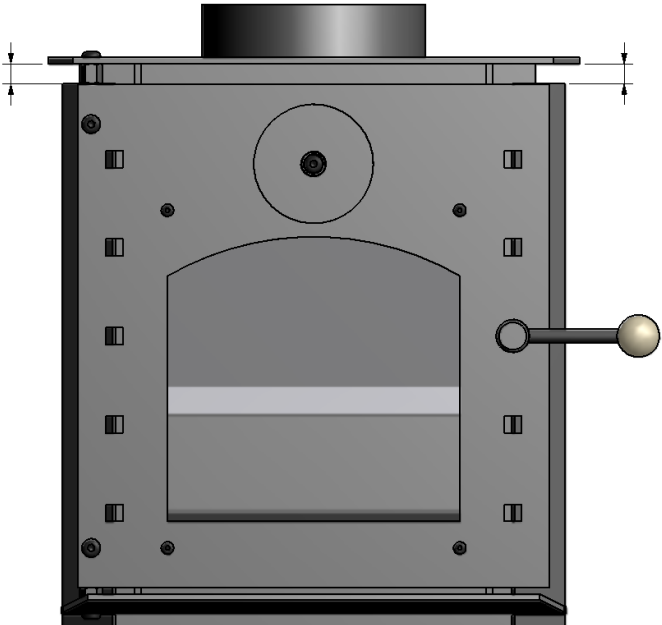

No : 5

Tighten up the Cap Screws on the Top & Bottom Door Front first .

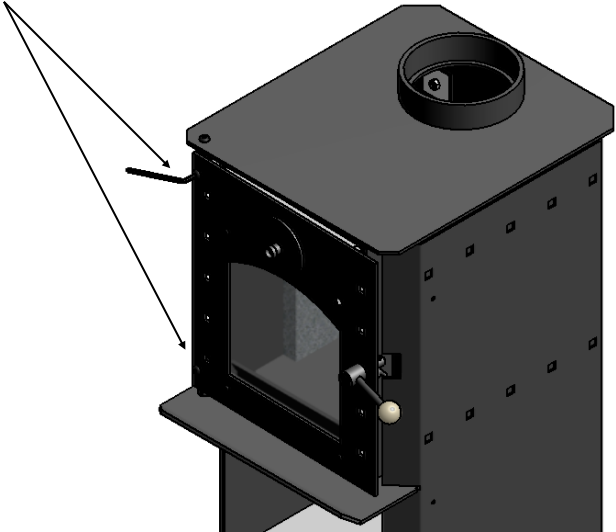

Due to continued product improvement, Warmington Ind LTD reserves the right to change product specifications without prior notification.

All Dimension are in mm.....Copyright ©

No : 6

Ensure that the Door is hard back on the Hinge Side and tighten the top and bottom Nuts while holding the Button head cap screw with the 5mm Allen Key and Spanner .

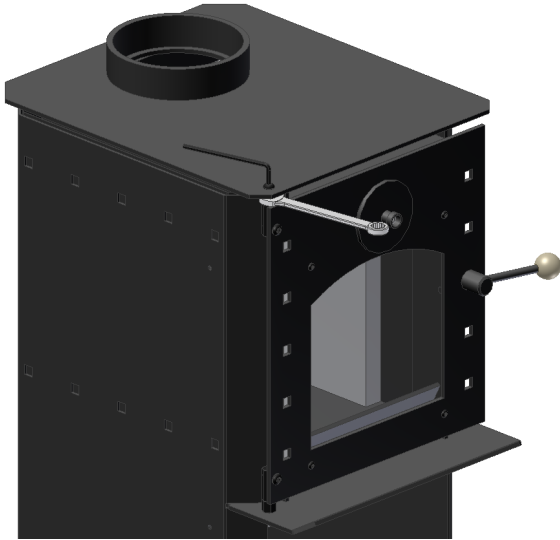

No : 7

Ensure that the Door is parallel to the Top of the Fire.

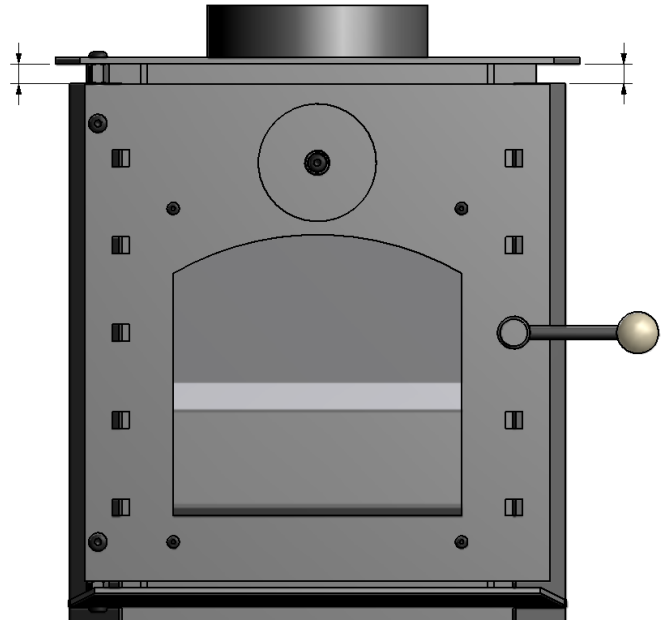

Check both ends of the doors to make sure it is parallel to the unit.

No : 8

Ensure that the Door Seal is mating with the Door Frame and making a seal by looking along the door and seal as they mate. If it is not mating correctly , repeat adjustment pro-

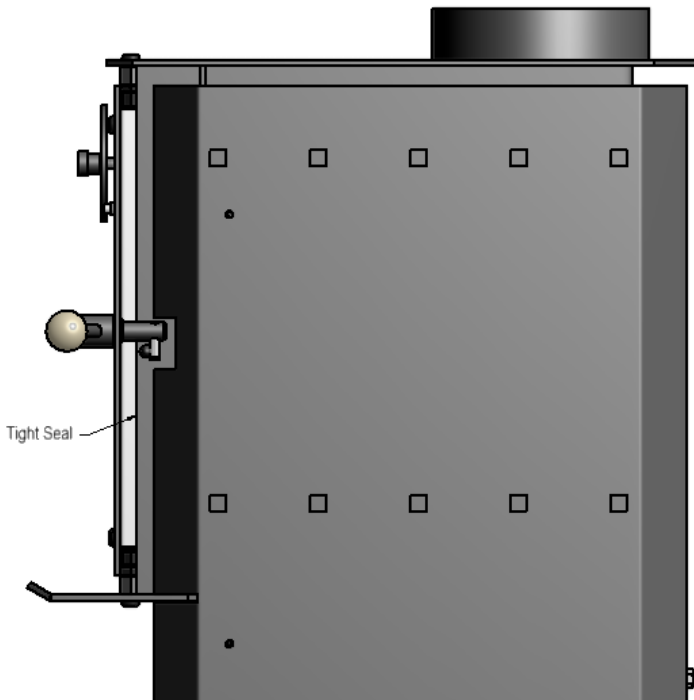

No : 9

Check the Seal by opening the Door and placing a piece of Newspaper between the Door Frame and the Door Seal , close the Door and see if there is some resistance when removing the Newspaper . This will prove if the Door is Sealed . If seal is not made, repeated the adjustment process or a new Door Seal Rope may be required or repeat the Adjustment process .

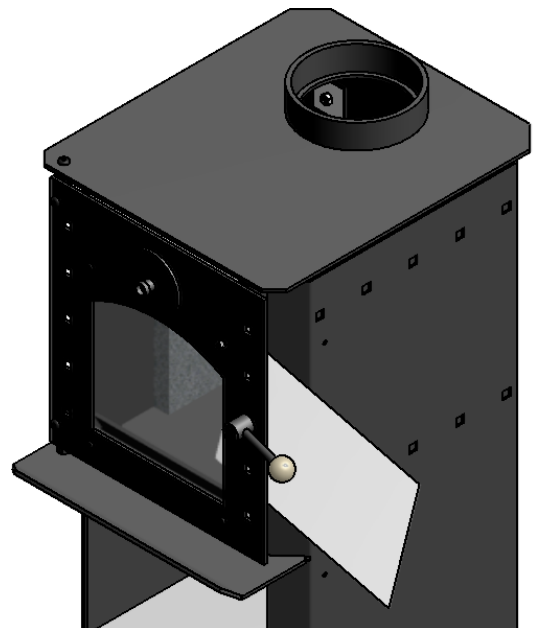

Nip up screws while holding door in place, then tighten fully with a 5mm Allen Key.

GENERAL INFORMATION & OPERATION

1. Double Skin

The Southern Series & Studio Oven Firebox is a radiant/convection stove – it has an inner and outer skin whereby room air flows between the surfaces, thus becoming hot and efficiently heating the room.

2. Lighting and Operation of Studio Oven

- When lighting the Studio Oven the Firebox Damper Control, the Disk at the Top of the firebox door, should be fully open .
- Place paper or fire lighters into the base of the firebox .
- Arrange kindling on top of paper or firelighters, allowing air to move easily through the kindling also Open Oven Damper Control on RH Side (push back) to allow the Hot Flame & Smoke to bypass the oven and pass up the Chimney.
- Light the fire around the base to ensure good ignition of paper or firelighters.
- Leave the door ajar 5 to 10 mm to aid with speedy ignition of the fire. **Do not run the fire for long periods with the door ajar as damage may result.**
- When the fire is happily burning the main flue loads can be placed into the fire, from the front to the rear in a lined pattern, ensuring that the flames can easily move through the fuel load.
- Close the door to ensure a seal to the firebox and pull the Oven Damper Control on the RH side forwards (closed). **Always operate the fire in the “heat oven position”** (Oven Damper Control forwards as this will return maximum heat into the home).

Once the fire is fully established and burning brightly the air supply can be considerably reduced to control heat output (and fuel consumption). Note, the air control is designed such that even when fully closed some air still enter the firebox. This keeps unwanted flue emissions to a minimum.

NOTE: Operating the Studio Oven with the oven damper control forwards (closed) once fire is well established, will heat up the oven below & give maximum amount of heat into the room. If the fire performance drops or the oven will not reach temperature, the Studio Oven may need to be swept and cleaned of soot build-up (see sweep details).

When re-fuelling the fire, open oven damper control on RH side of firebox, i.e. push back. This will avoid smoke entering the home. Once the fire is re-fuelled , close the door & pull the Oven Damper Control Forward to heat the Oven .

Removing Ash

When you use your fire for a few weeks you will find ashes accumulate in the firebox. The ashes can be removed easily through the fire door when the fire is at its lowest, such as first thing in the morning, or when it is completely out. The amount of charcoal in the ash is often a good indicator of how well you are operating the heater. If there is no charcoal and only very fine ash then you are doing an excellent job. If there is a lot of charcoal you may be turning the combustion air down too soon after refueling, or not raking the charcoal to the combustion air inlet, or turning the combustion air down too low to support efficient combustion, or all of the above. Warmington wood-burning appliances work best when a small amount of ash is left approximately 25mm deep in the firebox after cleaning, this aids with stable burning. The ash should be placed in a noncombustible container with a tightly fitting lid and moved outdoors immediately to a location clear of combustible materials.

4. Cooking

Because the top of the fire is in direct contact with the flame, it offers a large cooking surface. Ideal for entertainment at home or cooking for holiday homes and farm cottages. If spillage occurs, clean the surface with a soft cloth and dish washing liquid, avoid scratching the surface.

5. Storing/Drying Fuel

Damp wood is dried naturally while it is stored. Use dry timber preferably cut and stored under cover the previous year.

PURCHASING THE FIREWOOD

The quality of the firewood you burn can have a dramatic effect on the efficiency and operation of the heater. The main factors that affect the burning characteristics of firewood are moisture content, tree species and piece size.

The moisture content of the wood affects the rate at which burns and the efficiency of combustion. When trees are cut, wood moisture content ranges between 35 and 60 percent by weight. If you attempt to burn wood this wet, it will be hard to ignite, slow to burn and will hiss and sizzle in the firebox. So much energy will be consumed in boiling off the excess water that the efficiency of combustion and the heat to your home will be low, condensation and corrosion may be occurring in the flue and smoke may be causing problems to your neighbours. Properly seasoned wood ignites readily and burns efficiently.

Firewood should be cut and split in the early spring and stacked under cover, with good ventilation, to be ready for burning when required.

Look and check for cracks in the end grain as a sign of dry wood. The stacks of firewood should be in an open area so that air can circulate between them. During the summer, as warm breezes flow through the stacks, carrying away the evaporating water, the moisture content of the wood will fall to around 20 percent. At this moisture content the wood is ready for burning.

Although the energy content of dry wood per kilogram is almost the same regardless of species, softwoods and hardwoods burn differently because of differences in density. Softwoods, such as pine, are less dense than hardwoods like gums, Manuka or ironbark. A denser wood will produce a longer-lasting coal bed, while a less dense wood will bring a fire to an optimum burning temperature more quickly.

The size of the firewood pieces affects the rate of combustion. Larger pieces ignite and release their energy more slowly than small pieces. Smaller pieces are better for short, hot fires and larger pieces are preferable for extended firing cycles. In general, commercial firewood dealers produce firewood in larger pieces than modern wood-burning appliances can handle. It is often necessary to split some of the wood again before using it.

Firewood harvesting can have an effect on native woodlands and a variety of threatened species. Dead standing and fallen timber provides habitat for numerous species of animals and birds. Wood heater operators should be encouraged to be sensitive about the source of their firewood. If collecting it privately, operators should leave some dead wood behind as it provides habitat for birds and animals.

Due to continued product improvement, Warmington Ind LTD reserves the right to change product specifications without prior notification.

All Dimension are in mm.....Copyright ©

GENERAL INFORMATION & OPERATION cont..**6. Heat Output**

A maximum heat output of approximately 10 - 12Kw can be expected with dry wood, with medium air control setting output of 6 - 8Kw and with fully closed the heat output is approximately 3 -4Kw. . The height of the flue system can have an effect on the draw, control and burn periods of the fire.

The stove will heat an area of approximately 90 - 110 sq meters of 2.4 meter stud height.

NOTE : The condition, moisture content and type of wood burned will have a direct result on the performance of the fire.

7. Construction

The firebox is constructed from 6mm steel plate with some fairings made from 1.6mm steel. The outer skin and tray are constructed from 3mm and 1.6mm steel plate. The unit has a cast steel door and 5mm Robax glass.

8. Finish

High temperature steel parts are finished with a matt black high temperature paint designed to withstand the rigors of normal combustion.

9. Glass Door

When in operation, the full beauty of the combustion process can be seen through the large ceramic-glass window. This window is kept clean by the inlet air passing from top to bottom over the glass. Any build up of residue that may occur on the glass can be removed with a mild abrasive liquid cleaner or proprietary stove glass cleaner. Wet wood is more likely than dry wood to produce window-marking emissions.

10. Testing and Clean Air Approval

The Studio Oven has been tested and approved to AS/NZS 2918: 2001 specifications for solid fuel burning heaters .Contact with your local TA (Territorial Authority) to check for local compliance.

11. Flue System

The installation and construction of the flue system must comply with AS/NZS : 2918. The fire requires a Warmington Tested and approved flue system only, as tested to AS/NZS : 2918. The tested flue system should not be modified in any way without the written approval of the manufacturer. Any additional flue components to the flue system must comply with AS/NZS : 2918.

12. Floor Protection

Floor protectors are normally designed to suit each individual "setting". The installation and construction of the floor protector must comply with AS/NZS:2918. The fire requires an ash hearth as needed for some types of wood burners.

13. Maintenance

The operation, components and general condition of the fire and flue system need to be checked annually, or more frequently if required. Repair or replace parts when necessary. For more information, contact your local retailer.

The chimney, firebox and fire ducts are to be cleaned and swept annually or more frequently if required.

Note: For cleaning and maintenance of the damper handle rod see page 6 for applying high temp grease etc.

Chimney Maintenance:

To clean chimney, remove cowl assembly from the top of the flue system, and the baffle system inside the top of the firebox. Make sure the door is closed on the firebox and push the oven damper control back to open, to ensure the soot can fall into the top firebox. Use a chimney sweeping brush to suit flue diameter, and clean the flue from the top down. Remove soot/ash from the firebox and fire ducts (see instructions in this document).

Firebox:

Keep your stove clean by polishing all over with a soft cloth when unit is cool. In humid climates more interior firebox corrosion will occur in non-use summer months than in winter. The stoves life can be greatly extended by cleaning the firebox interior at the end of winter and spraying with Stovebright high temperature black paint.

14. Wetback

On special order a wetback model can be supplied. This unit acts as a hot water booster, producing about 2.5kW. The wetback sits in the firebox . The inlet and outlet are at the fire back and require standard 25mm pipe connections to the threaded brass pipe of the wetback. Inlet and outlet pipes are at the same height permitting flow of water in either direction but need to be correctly connected by the plumber.

Note: Not all fires have the provision for a Wet Back.

GENERAL INFORMATION & OPERATION cont..**15. Suggested procedures for soot or creosote fire”****In the event of a soot or creosote fire**

- Alert all the people in the house. Either have them leave, or be ready to leave.
- Call the fire department.
- Suppress the fire the best you can until the fire department arrives, being careful of your own safety. Be sure you always have a way out of the house should the fire get out of hand.

If you can, being careful of your own safety:

- Close the air inlet(s) of the appliance.
- Discharge a dry chemical household fire extinguisher into the appliance.
Use a chimney fire extinguishing product (water on the base of the fire will turn to steam and aid to put out the fire)

16. Warranty - for full details and conditions on product Warranties, contact your Authorised Retailer.

The Studio Oven is guaranteed against faulty workmanship and materials for a five-year period.

The black surface while extremely durable and long lasting, may need buffing lightly with a soft cloth from time to time to retain its colour and appearance, or touching up with an approved high temperature paint i.e. Stovebright.

Not included in Warranty: (list of Warmington genuine replacement parts)

1. Glass in the doors (Robax glass 5mm fire box - Toughened Glass in the oven door)
2. Door seals. Firebox and Oven
3. Internal baffle system (consumable)
4. Firebox linings - (consumable - may not be fitted with some models)
5. Flue system
6. Paint (Stovebright)
7. Handles
8. Temperature Gauge

17. Installation

The fire is to be installed by a certified Warmington installer or an Approved NZHHA Installation Technician.

GENERAL INFORMATION ON PAINT & FINISHING

Information on the paint coating is on the web site: http://www.forrestpaint.com/stovebright/troubleshooting_guide1.html

When lighting the fire for the first time

Ventilate the house during the first three times the stove is used. The paint on the stove will give off smoke heavy with carbon dioxide and has an odour. Without adequate ventilation, concentrations of smoke could irritate, or be upsetting. Babies, small children, pregnant women and pets should not be in the area due to these carbon dioxide fumes causing an imbalance in the air quality. Open doors and windows and use a fan if necessary. After these initial burns, the paint will be set and there should be no more smoke. Don't touch the surface. It will be soft and gummy during this phase. Once set, it will not be soft again.

Most stoves stop smoking after 3 burns. The first two should be at 250 F (121 C) for 20 minutes or about half a normal fire. Do not let the stove cool down significantly between burns. The last fire should be between 500 F (260 C) and 700 F (371 C) for at least 45 minutes. The point being, operate slowly without a hot fire. If the stove gets too hot, too quickly, the paint will crack. Owners of stoves that have a door gasket should check with the stove dealer about leaving the door ajar during this process to keep the gasket from sticking to the jam.

Stoves with a cooler surface temperature and those that were previously painted with another colour will take longer to set. This process can usually be observed by the effect of the paint turning flat as the heat radiates out from hotter parts of the stove.

Summary on Setting High Temp Paint -

Read Stove Manufacturer instructions.

Babies, small children, pregnant women and pets should leave the area during the paint setting phase.

Ventilate well.

Paint surface will look “wet” and will smoke.

Do not touch paint surface during this process.

Set slowly with successive burns.

Contact your local Warmington Retailer if you have any other questions.

Due to continued product improvement, Warmington Ind LTD reserves the right to change product specifications without prior notification.

All Dimension are in mm.....Copyright ©

GENERAL NOTES : ASNZS 2918 : 2001

NOTES:

- Warranty - for full details on product warranties, contact your local Authorised Warmington Retailer.
- For the fire Operational and Maintenance Instructions visit www.warmington.co.nz and up load the PDF.
- Correct installation, operation and maintenance must be maintained to comply with Warmington Warranty.
- The Appliance and Flue System must be Installed in accordance with ASNZS2918:2001 and the appropriate Building codes.
- The flue system and fireplace is to be swept annually or more frequently if required.

WARNINGS:

- **WARNING; ANY MODIFICATION OF THE APPLIANCE THAT HAS NOT BEEN APPROVED IN WRITING BY THE TESTING AUTHORITY IS CONSIDERED AS BREACHING AS/NZS : 4013.**
- **WARNING; DO NOT USE FLAMMABLE LIQUIDS OR AEROSOLS TO START OR REKINDLE THE FIRE.**
- **WARNING; DO NOT USE FLAMMABLE LIQUIDS OR AEROSOLS IN THE VICINITY OF THIS APPLIANCE WHEN IT IS OPERATING.**
- **WARNING; DO NOT STORE FUEL WITHIN HEATER INSTALLATION CLEARANCES.**
- **WARNING; WHEN OPERATION THIS APPLIANCE AS AN OPEN FIRE USE A SPARK SCREEN.**
- **CAUTION:** THIS APPLIANCE SHOULD BE MAINTAINED AND OPERATED AT ALL TIMES IN ACCORDANCE WITH THESE INSTRUCTIONS AC-
- **CAUTION:** THE USE OF SOME TYPES OF PRESERVATIVE-TREATED WOOD AS A FUEL CAN BE HAZARDOUS.

Model	Estimated KW	Average KW
Studio Oven	12	8-10

Tested Fuel Load (Softwood)	Kg	Fire Box Litres : Approx.
Studio Oven	up to 2.55kg	27

NOTE: For Operation Instruction download from the website www.warmington.co.nz



Industries 1994 LTD
PO Box 58652, Botany 2163, Auckland
www.warmington.co.nz

Due to continued product improvement, Warmington Ind LTD reserves the right to change product specifications without prior notification.

All Dimension are in mm.....Copyright ©