

Southern Series

Southern Series - Wood Burner Installation Instructions

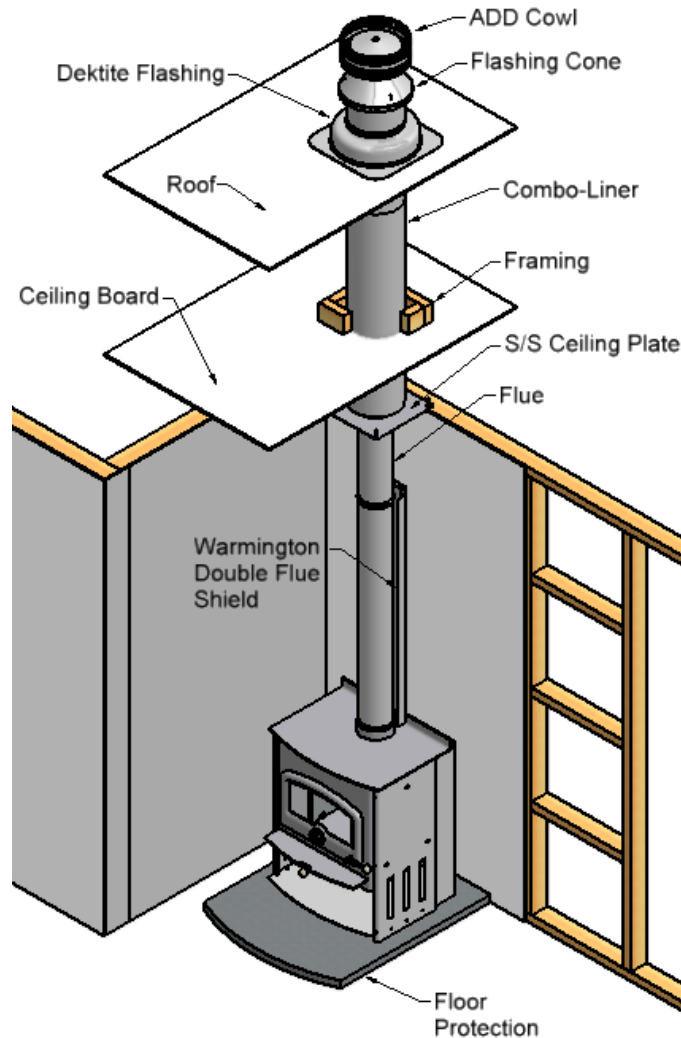

Visit www.warmington.co.nz for Spec's, DWG's and PDF uploads of Fires

Fire, Flue System and Instructions to Comply with AS/NZS 2918:2001

Keep these Instructions for further reference.....Ensure that you have the correct and current Installation details for the Warmington Fire

Installation

The Warmington unit is to be Installed by a Certified Warmington Installer or a Certified NZHHA SFAIT Installation Technician .
See www.warmington.co.nz/members for a Certified NZHHA SFAIT Installer in your area .

CLEARANCES TO COMBUSTIBLE SURFACES UNLESS STATED

IMPORTANT

Read all the instructions carefully before commencing the Installation. Failure to follow these instructions may result in a fire hazard and void the warranty

Due to continued product improvement, Warmington Ind LTD reserves the right to change product specifications without prior notification.

ModelLewis

Serial No: LECA -

Emission Report No: **06/1390 Applied Research Services LTD**

TESTED TO **AS/NZS 4013**.

BURN ONLY UNTREATED WOOD WITH MOISTURE CONTENT LESS THAN 25% (DRY BASIS)

AVERAGE PARTICULATE EMISSION FACTOR BURNING SOFTWOOD – **0.81g/kg**

MAXIMUM AVERAGE HEAT OUTPUT BURNING SOFTWOOD - **10.1KW**

OVERALL AVERAGE EFFICIENCY BURNING SOFTWOOD - **72.1%**

Council Authorisation No. Ecan & Nelson: 071229

When Tested in Accordance with **AS/NZS 4012**

Performance may vary from tested values depending on actual operating conditions.

Date of installation: ____/____/20____

ModelLindis

Serial No: LNCA -

Emission Report No: **06/1385 Applied Research Services LTD**

TESTED TO **AS/NZS 4013**.

BURN ONLY UNTREATED WOOD WITH MOISTURE CONTENT LESS THAN 25% (DRY BASIS)

AVERAGE PARTICULATE EMISSION FACTOR BURNING SOFTWOOD – **1.19 g/kg**

MAXIMUM AVERAGE HEAT OUTPUT BURNING SOFTWOOD – **13.3KW**

OVERALL AVERAGE EFFICIENCY BURNING SOFTWOOD - **71.9%**

Council Authorisation No. Nelson: N0019

When Tested in Accordance with **AS/NZS 4012**

Performance may vary from tested values depending on actual operating conditions.

Date of installation: ____/____/20____

ModelMcKenzie

Serial No: MCCA -

Emission Report No: **0009 Spectrum Laboratories LTD**

TESTED TO **AS/NZS 4013.**

BURN ONLY UNTREATED WOOD WITH MOISTURE CONTENT LESS THAN 25%
(DRY BASIS)

AVERAGE PARTICULATE EMISSION FACTOR BURNING SOFTWOOD – **1.46g/kg**

MAXIMUM AVERAGE HEAT OUTPUT BURNING SOFTWOOD – **18.57KW**

OVERALL AVERAGE EFFICIENCY BURNING SOFTWOOD - **65.12%**

When Tested in Accordance with **AS/NZS 4012**

Council Authorisation No. **Nelson: N0020**

Performance may vary from tested values depending
on actual operating conditions.

Date of installation: ____ / ____ /20 ____

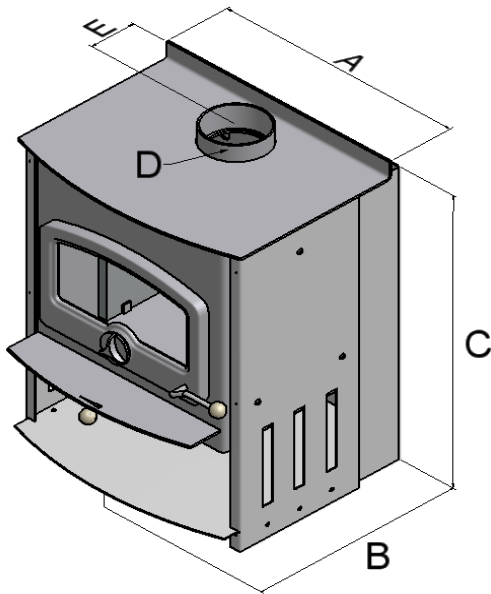
FIREBOX DETAILS

Description		Lewis	Lindis	McKenzie
Cabinet Width	A	580	660	660
Cabinet Depth	B	580	580	680
Cabinet Height	C	860	860	860
Flue Diameter	D	150	150	150
To Flue Centre	E	191	191	191
Ceiling Height	F	2400	2400	2400
Minimum from fire to Ceiling	G	1500	1500	1500
Height from Floor Protector	H	4600	4600	4600
Emission Levels (g/kg)		0.81	1.19	1.46

Situation	
1.	Non-combustible surface, including walls, finishings and framing without flue shield, e.g. concrete/block/brick/ACC block. Hearth only needed if installed on heat sensitive floor material. Re Clearance to a Non Combustible materials walls or surfaces Ref to ASNZS:2918:2001 3.2.1. The clearance to a Non Combustible wall or surface can be less that 100mm if a wet back is not fitted and no requirement for maintenance.
	* Construction of Flue Shield must be in accordance with ASNZS 2918 (minimum Flue Shield height is 1200mm)

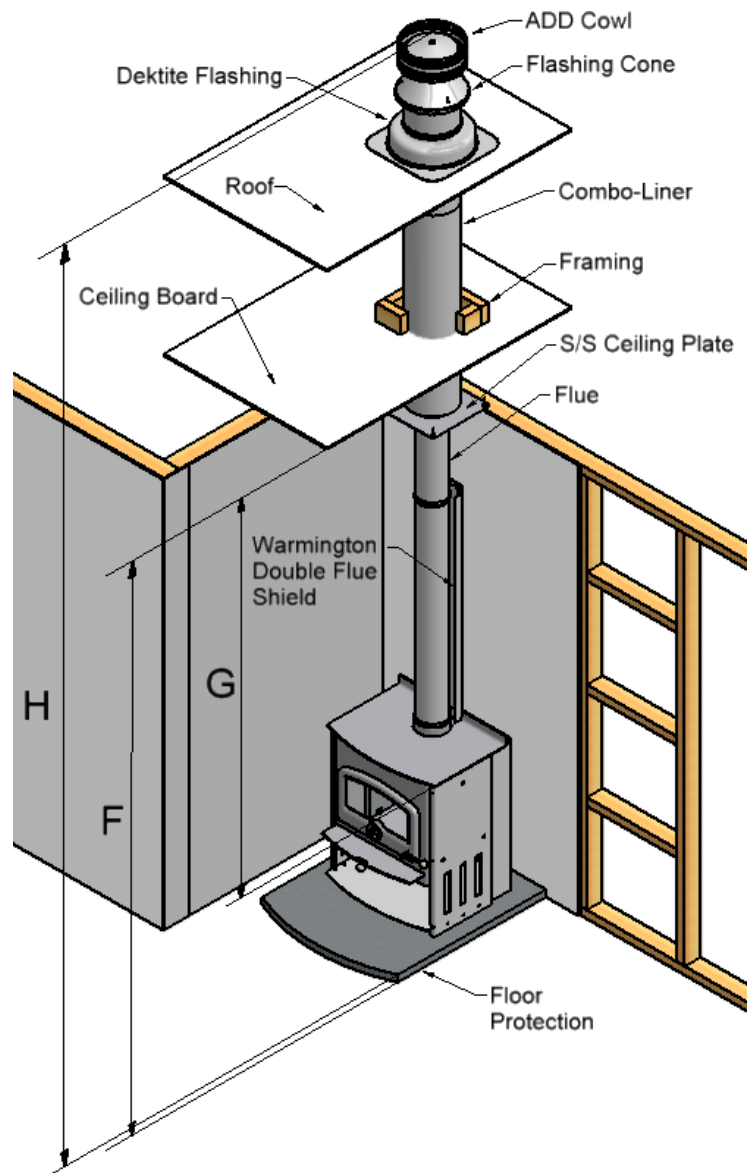
FLOOR PROTECTOR
Note: Floor Protection

Floor protectors are normally designed to suit each individual "setting".

The Southern Series requires a "ASH ONLY" floor protector as needed for some types of wood burners.

Check List	
Baffle	
Holding Down Bracket	
Check Door Seal	
Check Damper	
Bricks	
Serial Number Check	
Loading Badge	
Packed By	

Minimum Flue Height	
Flue Height	3600
Measured From Top of Cabinet	C + 3600

Due to continued product improvement, Warmington Ind LTD reserves the right to change product specifications without prior notification.

PLAN VIEW OF CLEARANCES TO COMBUSTIBLES —CORNER & STRAIGHT

Free-Standing Firebox-

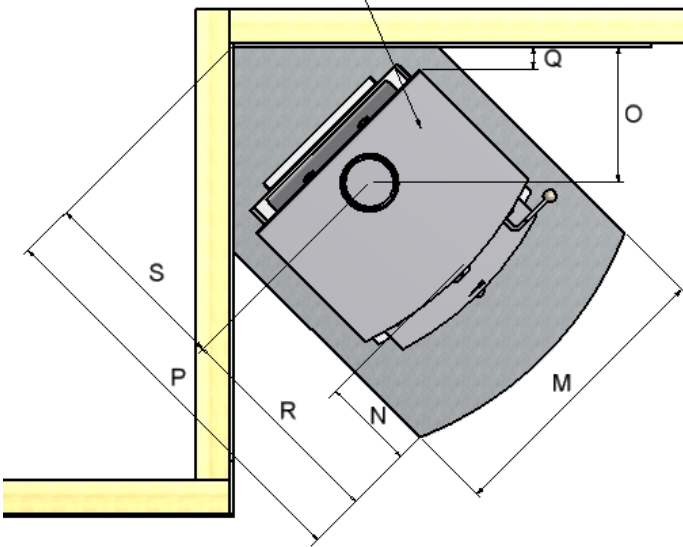

Description		Lewis	Lindis	McKenzie
To Wall Behind	I	100	100	100
To Wall Side	J	250	300	350
To Flue Centre	K	288	288	288
Hearth Depth	L	904	904	1004
Hearth Width	M	760	830	830
Hearth Projection*	N	300	300	300
To Flue Centre	O	363	391	425
Hearth Depth	P	1129	1169	1318
To Wall Side	Q	66	66	100
Hearth Projection**	R	616	616	716
To Flue Centre	S	513	553	601

* Measurement taken from front ash lip
 ** Measurement taken from flue centre

Note: Clearances
 Non-combustible surface, including walls, finishings and framing without flue shield, e.g. concrete/block/brick/ACC block. Hearth only needed if installed on heat sensitive floor material.
Re: Clearance to a non-combustible materials, walls or surfaces. Refer to ASNZS:2918:2001 3.2.1. The clearance to a non-combustible surface (including walls), can't be less than 100mm. If wetback is fitted, refer to Situation 1. above.

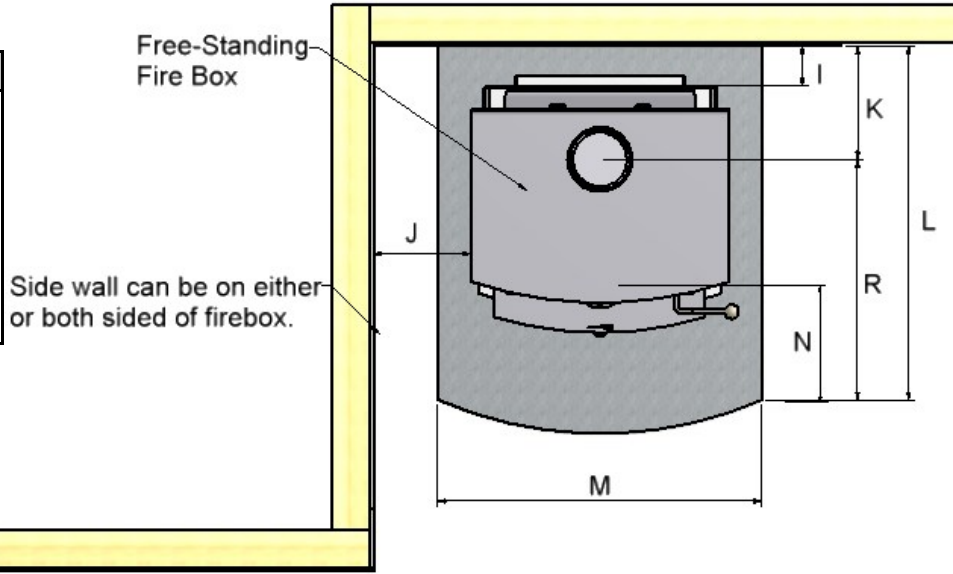

BAFFLE POSITION

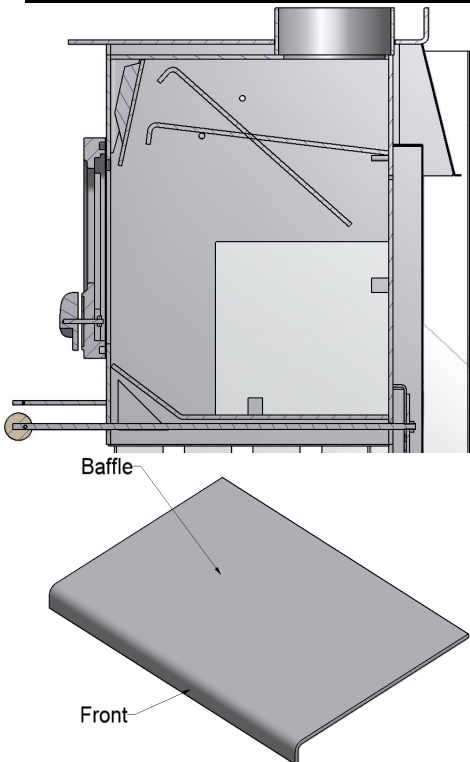

Note: For McKenzie
 Place K-O Wool on top of baffle before putting in place.

BRICK LAY OUT AND FITMENT

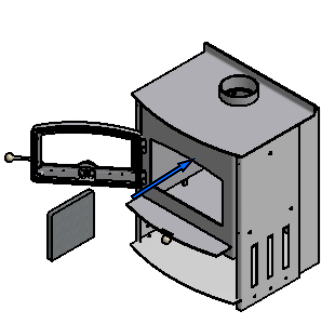

Step 1
 Unwrap 2x Bricks Supplied , Open Door & locate the Brick Support Brackets in side the Firebox on both Sides .

Step 2
 Place Brick inside Fire-box hard against Firebox Side & sit down on Fire-box Base using the (Base) Brick Support Bracket First . (As shown below)

Step 3
 Then Slide Fire Brick back into (Back) Brick Support Bracket . (As shown below) This is the same for both Bricks on each Side .

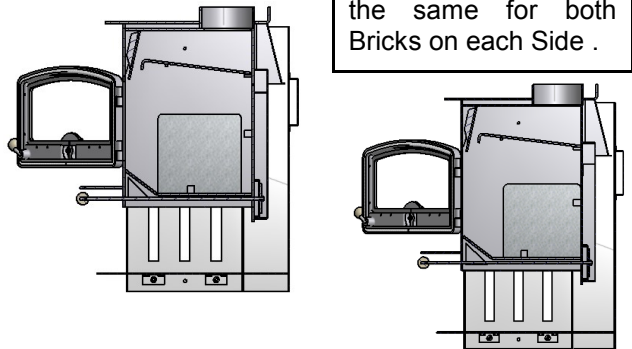

Due to continued product improvement, Warmington Ind LTD reserves the right to change product specifications without prior notification.

FITMENT & REMOVAL OF BAFFLE

STEP : 1

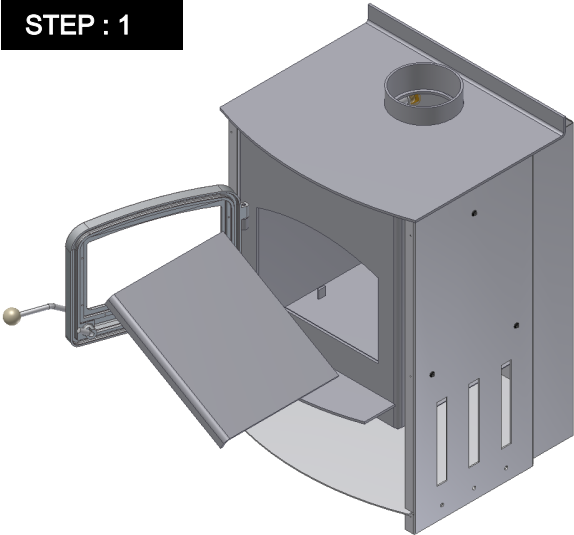

Remove Ash & Southern Series Bricks. Then Tilt Southern Series Baffle on an Angle and Slide into Firebox

STEP : 2

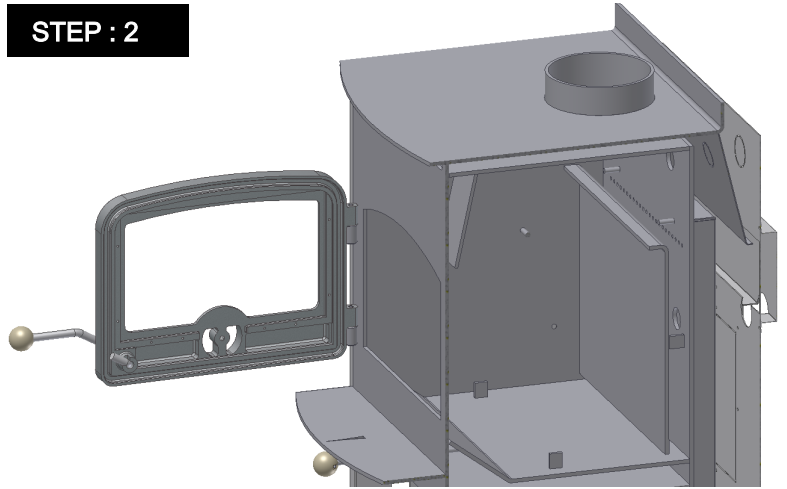

Rotate Baffle 90 Degrees & Push Baffle to Back of Firebox

STEP : 3

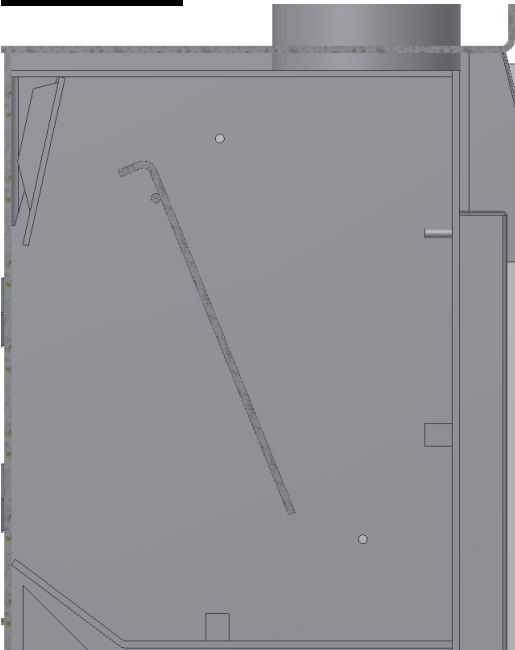

Move Baffle forward to sit on pins

STEP : 4

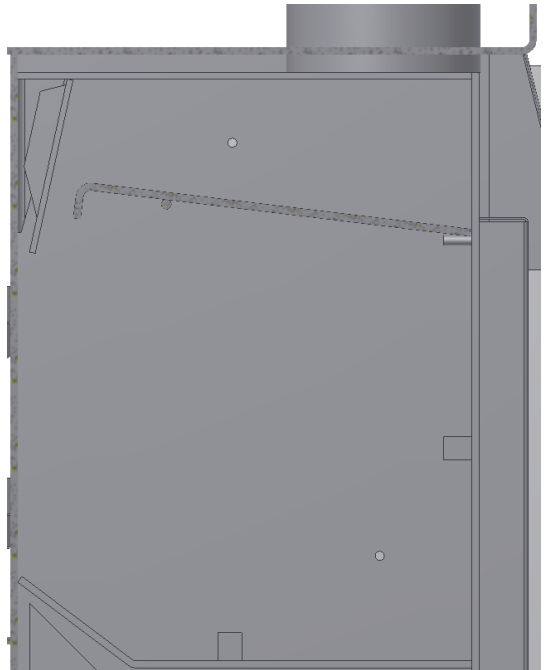

Move the Back of the Baffle up to sit on the pins at the back of the Firebox

Damper Control Position

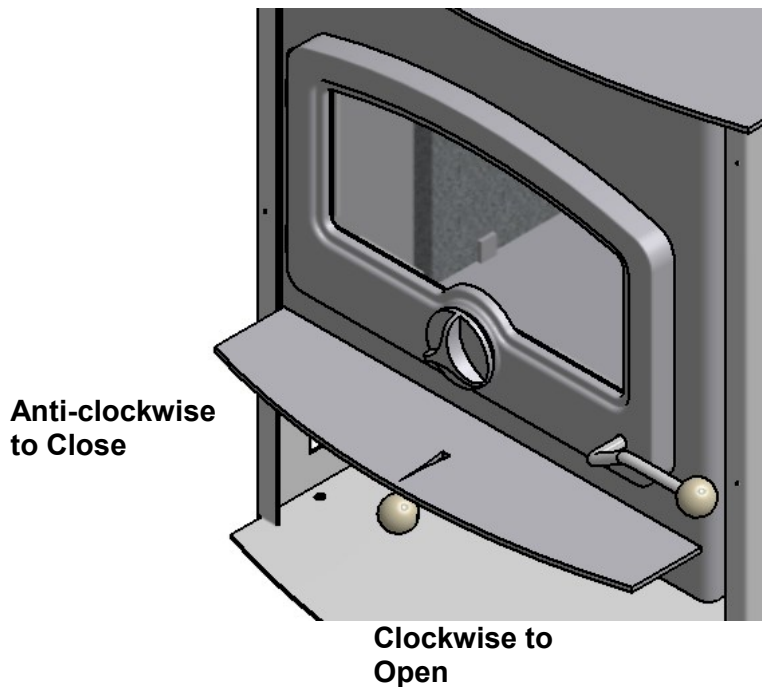

Operating Instructions for Damper Control

The Primary Air Control Handle (Wooden Knob) Controls the amount of Air drawn into the Firebox, and thus the combustion rate. Turning the Air Control Clockwise will let more air into the Fire thus giving higher peak power, but shorter burn time. Turning the Air Control Knob Anti-Clockwise will give you a longer burn time, but lower peak output .

- When lighting the Fire, the Air Control should be fully open (approx 10 turns) .
- Light Fire around the base to ensure good ignition of paper or firelighters .
- Leave the door ajar 5-10mm to aid speedy ignition of the Fire .
- When the Fire is burning well, the main fuel load can be placed into the Fire, from front to rear in a lined pattern, ensuring the flames can move through the Fuel Load .
- Close door to ensure a seal to the Firebox.

Once the Fire is fully established and burning brightly, the air supply can be reduced to control heat output (and Fuel Consumption).

Note: The Air Control is designed such that even when fully closed, some Air can still enter the Firebox . This keeps unwanted fuel emissions to a minimum .

Flue length will affect the burn rate of the Fire due to increased draw . A flue balance damper may be required . Contact your Installer for more information .

Burn times for the Southern Series Fires have been tested at 145 to 160 minutes from the last load .

Tested Fuel Load (Softwood)	Kg	Fire Box Litres : Approx.
McKenzie	up to 6.659kg	75
Lindis	up to 6.028kg .	60
Lewis	up to 4.77kg .	49

WETBACK POSITION

Bottom Wetback on 2010 Models Only

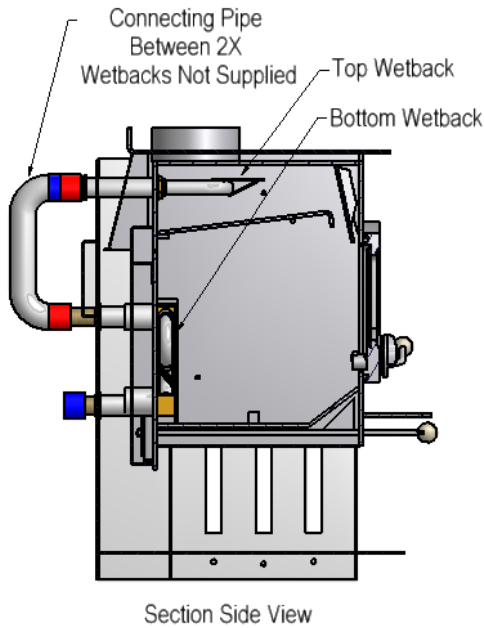

Plumbing Setup for 2X Top & Bottom Wetbacks

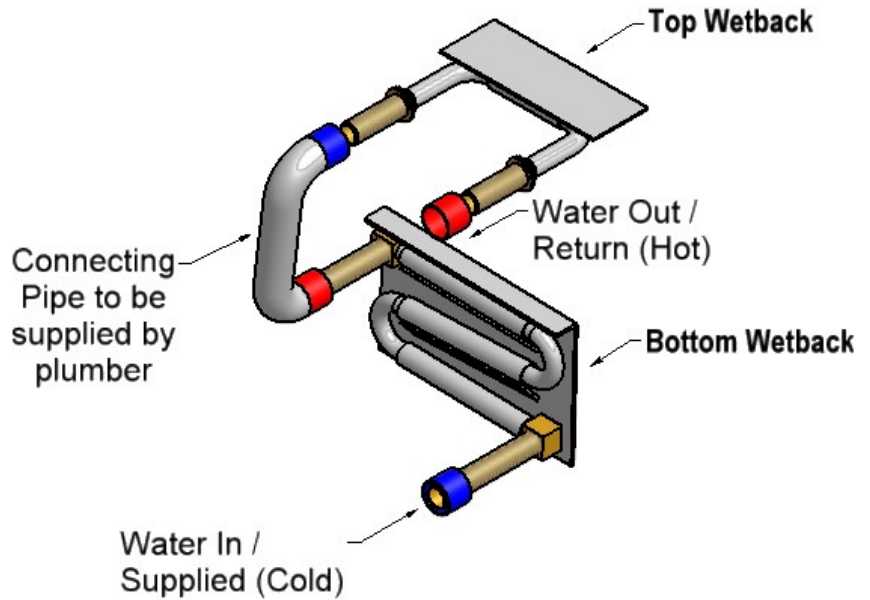

Note:
A Wet Back CANNOT be fitted to Fires that are Installed in any area that falls under Clean Air Regulations.

Wet Back Configuration	KW*
Top Only	2
Bottom Only	3
Top and Bottom	4

*Value is approx, tested on Lewis Firebox

Plumbing Setup for 2X Top & Bottom Wetbacks

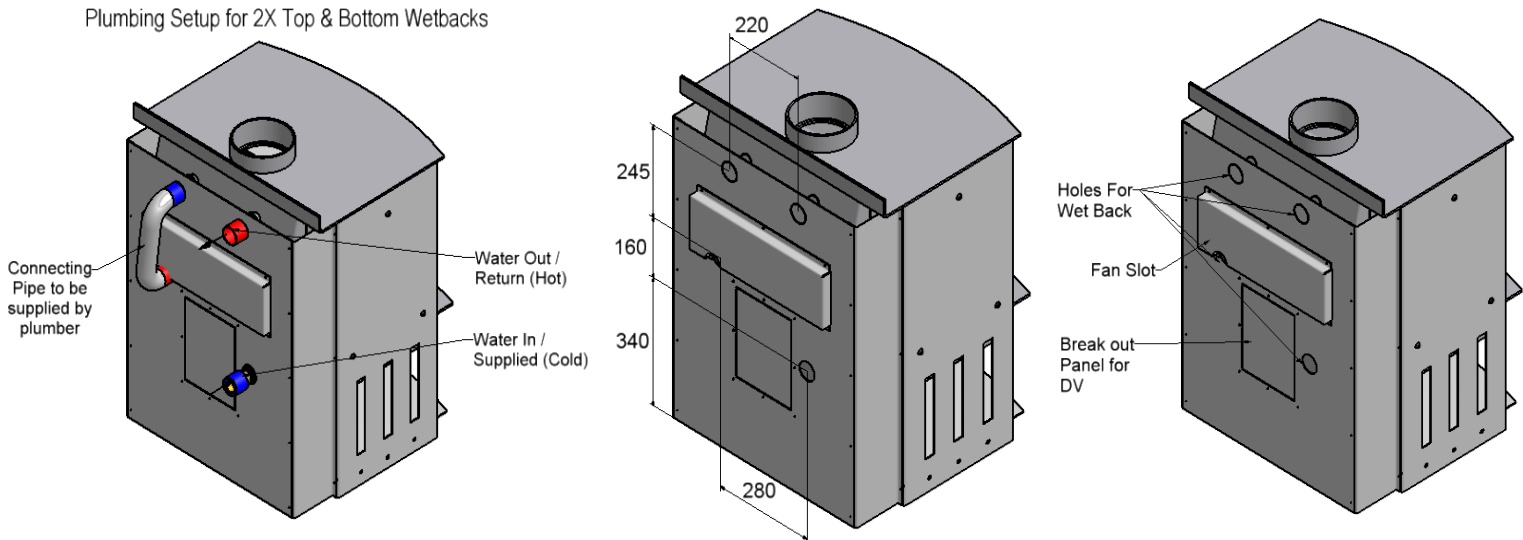

Note:
Consult your Plumber for Wet Back System Configurations and Operation.
Wet Back is to be fitted to an Internal Heat-Sync (e.g. Hot water cylinder / Radiator / Under floor heating etc...)

Note:
Fan Installation to be advised at a later date, due to further testing.

Due to continued product improvement, Warmington Ind LTD reserves the right to change product specifications without prior notification.

INSTALLING DIRECT VENT (D.V.) TO YOUR FIRE (Optional)

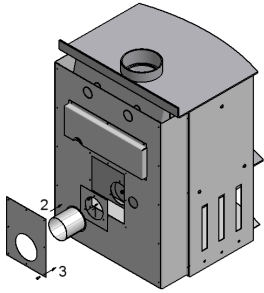

Instructions
 First remove the break out panel for the D.V. then place the spigot over the hole and screw the three 6mm screws into the holes while fixing the spigot in place. Place the supplied cover over the break out and fix with the eight 5mm screws supplied.

DV WALL SET UP (Optional)

Note:
 Holes in trim plate to be drilled on site, recommended hole size is Ø3.2mm.
 Screws are not supplied for fitting of vent.
 The vent should be sealed with a recommended sealant to ensure water does not enter floor or wall cavity.

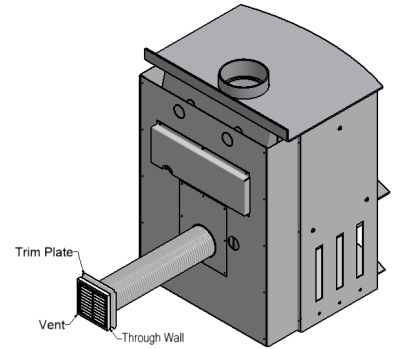

DV FLOOR SET UP (Optional)

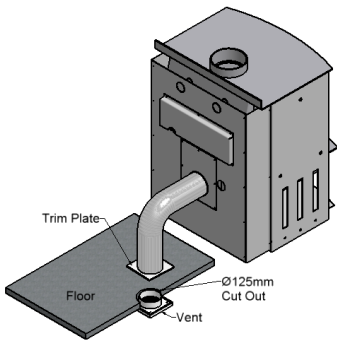

Direct Vent is NOT available to areas that fall within ECan boundaries.

D.V. Check List

DV Spigot	
8 x M5 Screws	
3 x M6 Screws	
DV Cover Plate	
Flexi Pipe	
Vent and Trim Plate	
Packed by	

SEISMIC RESTRAINT FIXING

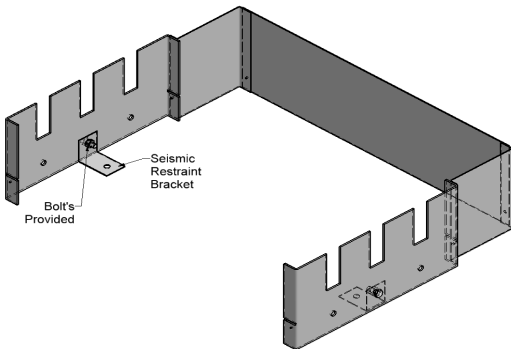

Seismic Restraint Fixing Instructions
 Remove bottom tray (Remove bolt at back of tray and slide shelf out)
 Fit seismic restraint bracket (2 at rear of unit)
 Fix bracket to floor through the hearth.
 Replace bottom shelf and bolt.

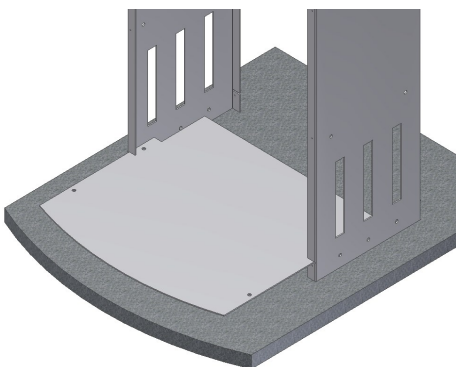

Seismic Restraint Fixing Instructions
 Fix 2X Seismic Restraints through the Hearth into the Floor . They are to penetrate into the fixing by at least 3 times their diameter.
 Use at least 2 x 6 to 8 mm Dia Dyna Bolts or similar to fix fire to hearth and or through the hearth to the floor.
 Fix hearth to floor with appropriate adhesive , bolt or screw.
 Ensure that the Seismic Restraint complies with ASNZS 2918:2001— Ref 3.8

Due to continued product improvement, Warmington Ind LTD reserves the right to change product specifications without prior notification.

FLUE SYSTEM INSTALLATION GUIDE

Minimum Flue Height	
Flue Height	3600
Measured From Top of Fire	C + 3600

Flue details	No:	Studio
Cowl	1	150
Cone	1	150
Top Spider	1	150
Liner Diameter Slip	1	250
Flue Diameter S/S	1	150
Flue Diameter Hi Therm Black	2	150
Combo 250/200 X 1200MM Galv	1	250
Ceiling Plate	1	150
Ceramics	4	
Double Flue Shield	1	To Suite 150

FLUE SYSTEM INSTALLATION GUIDE

This flue kit has been manufactured in accordance with AS/NZS 2918:2001 and tested to Appendix F. To ensure safety, this flue kit must be installed as outlined in these instructions. Heater and flue pipe clearances from combustible walls must be in accordance with heater manufacture's specifications and AS/NZS 2918:2001. These installation instructions are for tested appliances only.

THIS IS A GUIDE ONLY—EACH INSTALLATION WILL VARIATE DUE TO UNIQUE INSTALLATION REQUIREMENTS.

- STAGE 1:** Locate heater in its proposed position and mark a point on the ceiling that is directly above the centre of the heater's flue outlet. Check that the heater's location allows the **Outer Casing** to clear all structural roof timbers.
- STAGE 2:** Cut a 250mm square hole in ceiling. Directly above, cut a hole in roof to accommodate **Outer Casing**.
- STAGE 3:** Fit timber nogs around ceiling and roof holes, i.e. Nogs form a 250mm square aperture, which allows air to circulate freely over the **Outer Casing** surface.
- STAGE 4:** Position the **Outer Casing** so that it is flush with the underneath of the ceiling and protrudes through the roof the required height (Refer to AS/NZ 2918:2001 if more details are required. When calculating roof penetration height, allow for an extra 500mm that can be achieved by using the **Outer Casing Slip Extension**.
- A:** If the flue is within three metres of the ridge, the **Outer Casing** must protrude at least 600mm above the ridge of the roof.
B: If the distance from the ridge is more than three metres, the **Outer Casing** must protrude at least 1000mm above roof penetration.
- STAGE 5:** Fix an appropriate flashing around the **Outer Casing** to seal onto the roofing material.
- STAGE 6:** Assemble **Flue Pipes** together ensuring seams are in line. Secure each joint with three rivets or self-tapping screws. **Flue Pipes** must be assembled with crimped ends down (towards heater).
- STAGE 7:** Place **Ceiling Plate** over heater flue spigot, ensuring the folded edge up stands are facing ceiling.
- STAGE 8:** From the roof, lower **Flue Pipes** through **Outer Casing** into position. Ensure not to scratch the Hi Therm Flue coating. The Hi Therm Coating can be touched up with an approved Spray can (Stovebright). **NOTE: Some fires require the crimped end of the flue that fits into the Fires flue spigot to be trimmed back to from a snug fit. Seal flue to Fire box spigot.**
- STAGE 9:** From the roof, slide the **Inner Casing** into the **Outer Casing**, around the flue, until it rests 12mm above ceiling level on the **Swage Ring of the Outer Casing**.
- STAGE 10:** Before securing the **Outer Casing Slip Extension** to the **Outer Casing** with three rivets or self tapping screws, ensure the **Flue Pipes** extends above the top of the **Outer Casing Slip Extension** 145mm APPROX. The fitment of the **Cowl**, **Flashing Cone** and **Flue** is required to form a seal by the flange on the **Cowl**. Adjust **Slip Extension** to obtain this measurement. If minimum roof penetration heights described earlier can not be achieved, add sufficient stainless steel **Flue Pipe**.
- STAGE 11:** Fit **Top Spacer Bracket** to the **Flue Pipe** making sure the lugs fit snugly inside **Outer Casing Slip Extension**. Make sure **Top Spacer Brackets** fits hard down onto **Outer Casing Slip Extension**.
- STAGE 12:** Fit **Flashing Cone** over the **Flue Pipe** and push down firmly onto **Top Spacer Bracket**. Optional to secure with a rivet or self-tapping screw. The **Flashing Cone** should be flush with or 5mm above the finished **Flue Pipe**.
- STAGE 13:** Fit **ADD Cowl** but do not secure permanently, as removal for flue cleaning will be necessary. The **Cowl** will fit tight down onto the **Flashing Cone** forming a seal—ensure that the seal is formed. (The **Cowl**, **Flashing Cone** and **Flue** can be secured with a Stainless Steel screw but provision must be made for the removal of the **Cowl** for cleaning of the flue system.
- STAGE 14:** Fasten **Ceiling Plate** to ceiling using screws and spacers provided. Ensure an even air gap around **Flue Pipe** when fixing. Remove protective plastic from **Ceiling Plate**.
N.B. 12mm air gap between ceiling plate and ceiling must be maintained.
- STAGE 15:** Fit of the Flue Shield, fit **Bracket** to **Flue Pipe** above firebox and the bracket into the flue spigot on the fire.. Attach **S/S Reflector to brackets**, ensure that the plastic coating is removed from all the surfaces before lighting the fire.
- N.B.** It is the responsibility of the installer to ensure that the installation of the flue kit complies with AS/NZ 2918:2001, the appliance manufacture's specifications for flues and that relevant Local Body requirements are adhered to.

NOTE:
 Ensure that a Standard Tested Warmington Flue system is used on the Warmington fires.

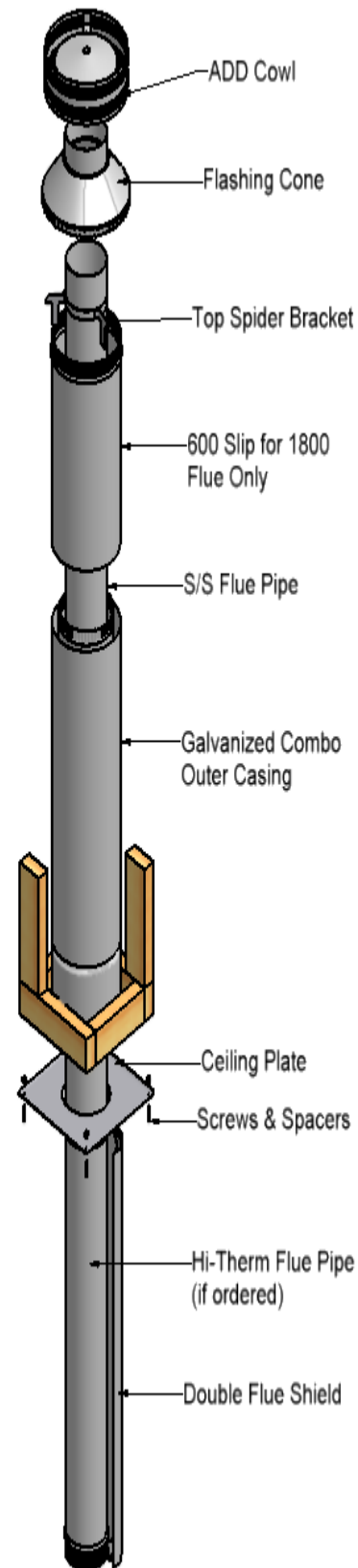

Due to continued product improvement, Warmington Ind LTD reserves the right to change product specifications without prior notification.

FLUE HEIGHT MINIMUM DETAILS

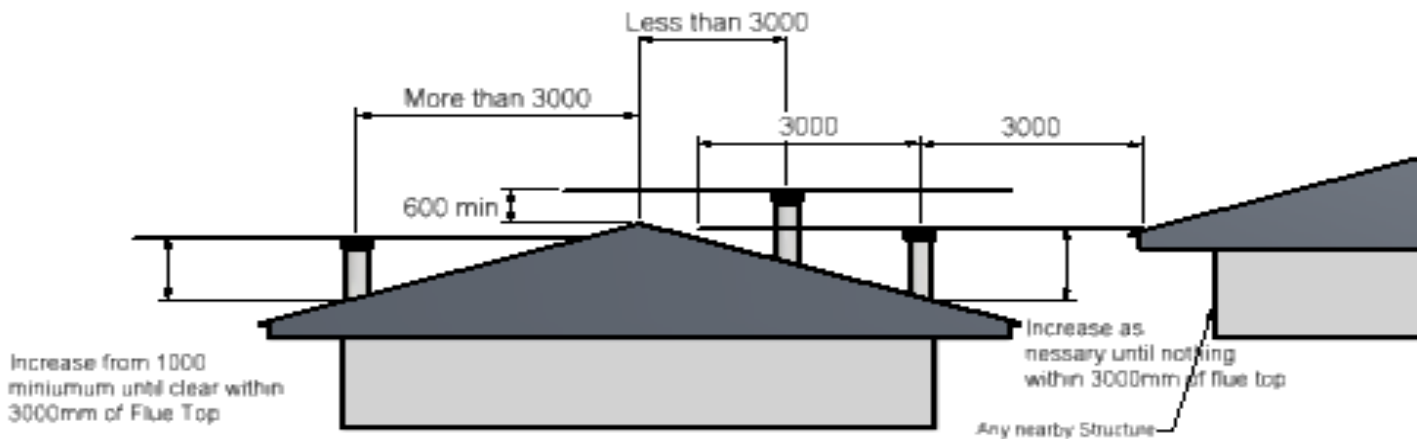

The flue exit is to comply to AS/NZS 2918: 2001

3D View

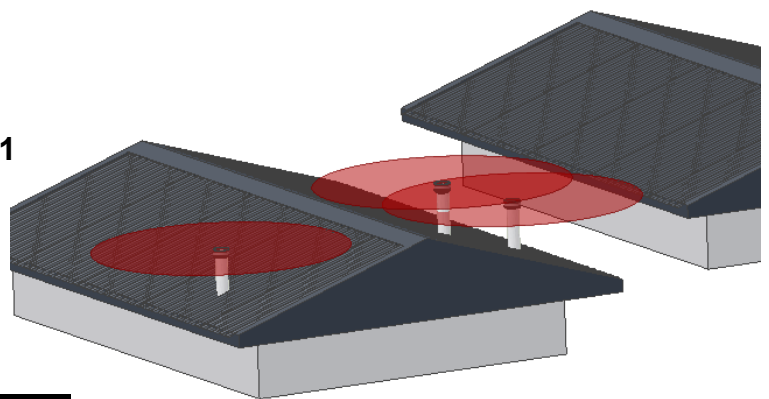

FLASHING—TO COMPLY TO THE BUILDING CODE (E2)

Note: ROOF FLASHINGS GENERAL:
 Flashing are to be complaint to the building code and the design will vary depending on the type of roof.
 Each installation is unique and your Installer will advise of the most appropriate flashing method to comply.

FRAME OUT - TRIM OUT DETAILS FOR FLUE SYSTEM

Note: FLUE SYSTEMS Casing....
 Flue system may require to be Doubled lined to comply.
 Ref AS/NZS:2918:2001 4.3 Flue pipe casing

Note :

External Requirements
 Refer to AS/NZS2918:2001 4.9.1

Install Flue system to AS/NZS2918:2001

When using a rubber or Bitumen flashing (Butynol, Dectite) an Additional Flue pipe Baffle is required.

All external air vents & ceiling penetrations must be bird proofed with permanently fixed screens.

All flashing to comply with E2.

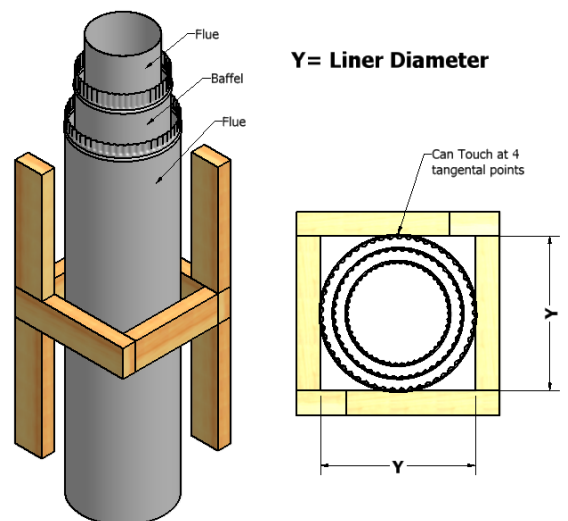

GENERAL INFORMATION & OPERATION

1. Double Skin

The Southern Series Firebox is a radiant/convection stove – it has an inner and outer skin whereby room air flows between the surfaces, thus becoming hot and efficiently heating the room.

1a. a convection air plenum is positioned on the rear of the firebox which is directed through a duct across the top of the heater moving hot air through the room.

2. Burns Twice

This statement is applied to many modern stoves. The combustion chamber is very efficient – air and volatile gases mix together and are more fully burnt. Spent gases exit through the flue.

3. Burn Control and Operation

The primary air control wooden knob controls the amount of air drawn into the stove and thus the combustion rate. Turning the air control clockwise will let more air into the fire thus giving you a higher peak power out but shorter burn time, screwing the air control knob anti-clockwise will give you a longer burn time however you will get a lower peak power output.

- When lighting the stove, the air control should be fully open (Turn the air control wooden ball clockwise).
- Place paper or fire lighters into the base of the firebox.
- Arrange kindling on top of paper or firelighters, allowing air to move easily through the kindling.
- Light the fire around the base to ensure good ignition of paper or firelighters.
- Leave the door ajar 5 to 10 mm to aid with speedy ignition of the fire. **Do not run the fire for long periods with the door ajar as damage may result.**
- When the fire is happily burning the main fuel loads can be placed into the fire, from the front to the rear in a lined pattern, ensuring that the flames can easily move through the fuel load.
- Close the door to ensure a seal to the firebox.
Once the fire is fully established and burning brightly the air supply can be considerably reduced to control heat output (and fuel consumption). Note, the air control is designed such that even when fully closed some air still enter the firebox. This keeps unwanted flue emissions to a minimum.

Removing ashes

When you use your fire for a few weeks you will find ashes accumulate in the firebox. The ashes can be removed easily through the fire door when the fire is at its lowest, such as first thing in the morning, or when it is completely out. The amount of charcoal in the ash is often a good indicator of how well you are operating the heater. If there is no charcoal and only very fine ash then you are doing an excellent job. If there is a lot of charcoal you may be turning the combustion air down too soon after refueling, or not raking the charcoal to the combustion air inlet, or turning the combustion air down too low to support efficient combustion, or all of the above. Warmington wood-burning appliances work best when a small amount of ash is left approximately 25mm deep in the firebox after cleaning, this aids with stable burning. The ash should be placed in a noncombustible container with a tightly fitting lid and moved outdoors immediately to a location clear of combustible materials.

4. Cooking

Because the top of the fire is in direct contact with the flame, it offers a large cooking surface. Ideal for entertainment at home or cooking for holiday homes and farm cottages. If spillage occurs, clean the surface with a soft cloth and dish washing liquid, avoid scratching the surface.

5. Storing/Drying Fuel

Damp wood is dried naturally while it is stored. Use dry timber preferably cut and stored under cover the previous year.

PURCHASING THE FIREWOOD

The quality of the firewood you burn can have a dramatic effect on the efficiency and operation of the heater. The main factors that affect the burning characteristics of firewood are moisture content, tree species and piece size.

The moisture content of the wood affects the rate at which burns and the efficiency of combustion. When trees are cut, wood moisture content ranges between 35 and 60 percent by weight. If you attempt to burn wood this wet, it will be hard to ignite, slow to burn and will hiss and sizzle in the firebox. So much energy will be consumed in boiling off the excess water that the efficiency of combustion and the heat to your home will be low, condensation and corrosion may be occurring in the flue and smoke may be causing problems to your neighbours. Properly seasoned wood ignites readily and burns efficiently.

Firewood should be cut and split in the early spring and stacked under cover, with good ventilation, to be ready for burning when required.

Look and check for cracks in the end grain as a sign of dry wood. The stacks of firewood should be in an open area so that air can circulate between them. During the summer, as warm breezes flow through the stacks, carrying away the evaporating water, the moisture content of the wood will fall to around 20 percent. At this moisture content the wood is ready for burning.

Although the energy content of dry wood per kilogram is almost the same regardless of species, softwoods and hardwoods burn differently because of differences in density. Softwoods, such as pine, are less dense than hardwoods like gums, Manuka or ironbark. A denser wood will produce a longer-lasting coal bed, while a less dense wood will bring a fire to an optimum burning temperature more quickly.

The size of the firewood pieces affects the rate of combustion. Larger pieces ignite and release their energy more slowly than small pieces. Smaller pieces are better for short, hot fires and larger pieces are preferable for extended firing cycles. In general, commercial firewood dealers produce firewood in larger pieces than modern wood-burning appliances can handle. It is often necessary to split some of the wood again before using it.

Firewood harvesting can have an effect on native woodlands and a variety of threatened species. Dead standing and fallen timber provides habitat for numerous species of animals and birds. Wood heater operators should be encouraged to be sensitive about the source of their firewood. If collecting it privately, operators should leave some dead wood behind as it provides habitat for birds and animals.

GENERAL INFORMATION & OPERATION

6. Heat Output

A Peak output of approximately 10.1Kw (Lewis) 13.3Kw (Lindis) to 18.57Kw(McKenzie) can be expected with dry soft wood. A maximum peak heat output of approximately 15 - 25Kw can be expected with dry wood. Due to the clean air requirements there is reduced control of the minimum heat out put and the fires have limited burn periods. The height of the flue system can have an effect on the draw, control and burn periods of the fire. The stove can heat an area of approximately 150 - 250 sq metres.

NOTE : The condition, moisture content and type of wood burned will have a direct result on the performance of the fire.

A Rural fire that can burn for longer periods can be ordered, but contact your local council for Installation and Clean air compliance requirements.

7. Construction

The firebox is constructed from 6mm steel plate with some fairings made from 1.6mm steel. The outer skin and tray are constructed from 3mm and 1.6mm steel plate. The unit has a cast steel door and 5mm Robax glass.

8. Finish

High temperature steel parts are finished with a matt black high temperature paint designed to withstand the rigors of normal combustion.

9. Glass Door

When in operation, the full beauty of the combustion process can be seen through the large ceramic-glass window. This window is kept clean by the inlet air passing from top to bottom over the glass. Any build up of residue that may occur on the glass can be removed with a mild abrasive liquid cleaner or proprietary stove glass cleaner. Wet wood is more likely than dry wood to produce window-marking emissions.

10. Testing and Clean Air Approval

The Southern Series range of fires have been tested and approved to ASNZS 2918:2001 specifications for solid fuel burning heaters and also to AS/NZS 4012 giving compliance with MFE(Ministry for the Environment New Zealand) clean air requirements in New Zealand and Australia. The stove has not been designed to operate with the door open for long periods. Clean air testing is conducted with the door closed. See the attached Data sheet on page 2, 3 and 4 and the data plate attached to the Fire. Contact with your local TA (Territorial Authority) to check for local compliance.

11. Flue System

The installation and construction of the flue system must comply with ASNZS 2918. The fire requires a Warmington Tested and approved flue system only, as tested to ASNZS 2918. The tested flue system should not be modified in any way without the written approval of the manufacturer. Any additional flue components to the flue system must comply with ASNZS 2918.

12. Floor Protection

Floor protectors are normally designed to suit each individual "setting". The installation and construction of the floor protector must comply with ASNZS 2918. The fire requires an "ash hearth" (floor Protector) as needed for some types of wood burners.

13. Maintenance

The operation, components and general condition of the fire and flue system need to be checked annually, or more frequently if required. Repair or replace parts when necessary. For more information, contact your local Retailer.

The chimney, firebox are to be cleaned and swept annually or more frequently if required.

Chimney Maintenance:

To clean the chimney, remove baffle plate inside the top of the firebox & close the door. With a ladder, access the roof and remove the cowl assembly. Make sure the door is closed on the fire & close air control (turn clockwise) to ensure soot etc. can fall into the firebox. With a chimney sweeping brush that suits the flue diameter, clean the flue ONLY from the top down. Remove soot/ash from the firebox. This is recommended to be done annually before each winter.

Firebox:

Keep your stove clean by polishing all over with a soft cloth when unit is cool. In humid climates more interior firebox corrosion will occur in non-use summer months than in winter. The stoves life can be greatly extended by cleaning the firebox interior at the end of winter and spraying with Stovebright high temperature black paint.

14. Wetback (Wetbacks can NOT be fitted to fires that are installed in any area that falls under clean air regulations, contact your local territorial authority for local compliance)

On special order a wetback model can be supplied. This unit acts as a hot water booster, producing about 2.5kW. The wetback sits above the firebox baffle. The inlet and outlet are at the fire back and require standard 25mm pipe connections to the threaded brass pipe of the wetback. Inlet and outlet pipes are at the same height permitting flow of water in either direction but need to be correctly connected by the plumber. **Note: Not all fires have the provision for a Wet Back.**

GENERAL INFORMATION & OPERATION

15. Suggested procedures for soot or creosote fire”

In the event of a soot or creosote fire

- Alert all the people in the house. Either have them leave, or be ready to leave.
- Call the fire department.
- Suppress the fire the best you can until the fire department arrives, being careful of your own safety. Be sure you always have a way out of the house should the fire get out of hand.

If you can, being careful of your own safety:

- Close the air inlet(s) of the appliance.
- Discharge a dry chemical household fire extinguisher into the appliance.
Use a chimney fire extinguishing product (water on the base of the fire will turn to steam and aid to put out the fire)

16. Warranty - for full details and conditions on product Warranties, contact your Authorised Retailer.

The fire is guaranteed against faulty workmanship and materials for a five-year period.

The black surface while extremely durable and long lasting, may need buffing lightly with a soft cloth from time to time to retain its colour and appearance, or touching up with an approved high temperature paint i.e. Stovebright.

Not included in Warranty: (list of Warmington genuine replacement parts)

1. Glass in the doors (Robax glass 5mm fire box)
2. Door seals. Firebox
3. Internal baffle system (consumable)
4. Firebox linings - (consumable - may not be fitted with some models)
5. Flue system
6. Paint (Stovebright)
7. Handles.

17. Installation

The fire is to be installed by a approved Warmington installer or an approved NZHHA SFAIT installation technician. See www.nzhha.co.nz/members for a NZHHA SFAIT installer in your area.

GENERAL INFORMATION ON PAINT & FINISHING

Information on the paint coating is on the web site: http://www.forrestpaint.com/stovebright/troubleshooting_guide1.html

When lighting the fire for the first time:

Ventilate the house during the first three times the stove is used. The paint on the stove will give off smoke heavy with carbon dioxide and has an odour. Without adequate ventilation, concentrations of smoke could irritate, or be upsetting. Babies, small children, pregnant women and pets should not be in the area due to these carbon dioxide fumes causing an imbalance in the air quality. Open doors and windows and use a fan if necessary. After these initial burns, the paint will be set and there should be no more smoke. Don't touch the surface, it will be soft and gummy during this phase. Once set, it will not be soft again.

Most stoves stop smoking after 3 burns. The first two should be at 250 F (121 C) for 20 minutes or about half a normal fire. Do not let the stove cool down significantly between burns. The last fire should be between 500 F (260 C) and 700 F (371 C) for at least 45 minutes. The point being, operate slowly without a hot fire. If the stove gets too hot too quickly, the paint will crack. Owners of stoves that have a door gasket should check with the stove dealer about leaving the door ajar during this process to keep the gasket from sticking to the jam.

Stoves with a cooler surface temperature and those that were previously painted with another colour will take longer to set. This process can usually be observed by the effect of the paint turning flat as the heat radiates out from hotter parts of the stove.

Summary on Setting High Temp Pain:

Read Stove Manufacturer instructions.

Babies, small children, pregnant women and pets should leave the area during the paint setting phase.

Ventilate well.

Paint surface will look “wet” and will smoke.

Do not touch paint surface during this process.

Set slowly with successive burns.

Call your Warmington retailer, or Installer if you have any further questions.

GENERAL NOTES : ASNZS 2918 : 2001

Note:

- Warranty - for full details on product warranties, contact your local Authorised Warmington Retailer.
- For the fire operational and maintenance instructions visit www.warmington.co.nz and download the PDF.
- Correct installation, operation and maintenance must be maintained to comply with Warmington’s Warranty.
- The appliance and flue system must be installed in accordance with AS/NZS 2918:2001 and the appropriate building codes.
- The flue system and fireplace is to be swept annually, or more frequent if required.
- The appliance and flue system has been tested to AS/NZS 2918:2001.

WARNINGS:

- **WARNING: ANY MODIFICATION OF THE APPLIANCE THAT HAS NOT BEEN APPROVED IN WRITING BY THE TESTING AUTHORITY IS CONSIDERED AS BREACHING AS/NZS : 4013.**
- **WARNING: DO NOT USE FLAMMABLE LIQUIDS OR AEROSOLS TO START OR REKINDLE THE FIRE.**
- **WARNING: DO NOT USE FLAMMABLE LIQUIDS OR AEROSOLS IN THE VICINITY OF THIS APPLIANCE WHEN IT IS OPERATING.**
- **WARNING: DO NOT STORE FUEL WITHIN HEATER INSTALLATION CLEARANCES.**
- **WARNING: WHEN OPERATION THIS APPLIANCE AS AN OPEN FIRE USE A SPARK SCREEN.**
- **CAUTION: THIS APPLIANCE SHOULD BE MAINTAINED AND OPERATED AT ALL TIMES IN ACCORDANCE WITH THESE INSTRUCTIONS**
- **CAUTION: THE USE OF SOME TYPES OF PRESERVATIVE-TREATED WOOD AS A FUEL CAN BE HAZARDOUS.**

Model	Estimated KW	Peak Output KW
Lewis	16	10.1
Lindis	19	13.3
McKenzie	25	18.57

Tested Fuel Load (Softwood)	Kg	fire box Litres : Approx.
McKenzie	up to 6.6kg	80.7
Lindis	up to 6.03kg .	63.7
Lewis	up to 4.77kg .	49.8

NOTE: For Operating Instruction download from the website www.warmington.co.nz



Industries 1994 LTD
PO Box 58652, Botany 2163, Auckland www.warmington.co.nz

Due to continued product improvement, Warmington Ind LTD reserves the right to change product specifications without prior notification.